

Eaton 9PX 6KVA Lithium-Ion

Advanced Users Guide

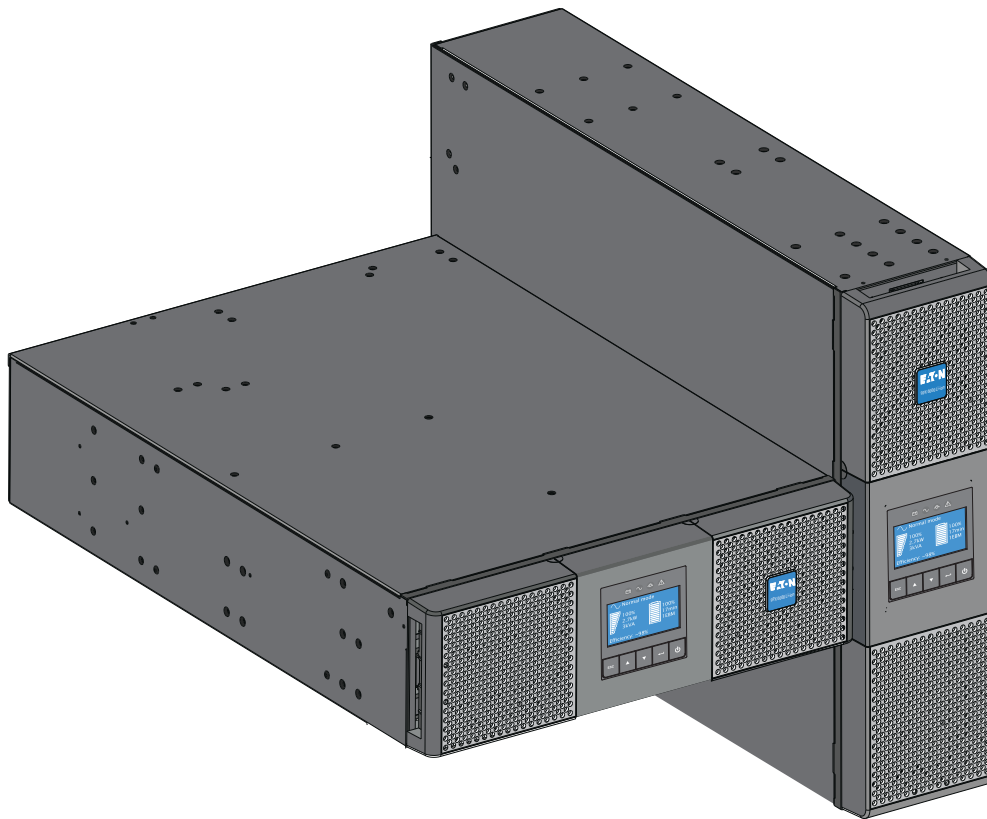

9PX6K-L
9PXEBM192RT-L

Safety Instructions

SAVE THESE INSTRUCTIONS.

This manual contains important instructions **that should be followed during installation and maintenance of the UPS and batteries.**

The 9PX models that are covered in this manual are intended for installation in an environment within 0 to 40°C, free of conductive contaminant.

Supplier's Declaration of Conformity of Federal Communications Commission Statement This device complies with Part 15 of the FCC Rules. Operation is subject to the following two conditions:

1. this device may not cause harmful interference, and
2. this device must accept any interference received, including interference that may cause undesired operation,

For questions regarding this FCC SDoC declaration, contact Eaton Corporation by telephone or through the Internet.

Eaton Corporation
8609 Six Forks Road,
Raleigh, NC 27615, USA
Telephone: 800-356-5794

Special Symbols

The following are examples of symbols used on the product to alert you to important information:



RISK OF ELECTRIC SHOCK - Observe the warning associated with the risk of electric shock symbol.



CAUTION: REFER TO OPERATOR'S MANUAL - Refer to your operator's manual for additional information, such as important operating and maintenance instructions.



This symbol indicates that you should not discard the UPS or the UPS batteries in the trash. This product contains sealed, Lithium-Ion batteries and must be disposed of properly. For more information, contact your local recycling/reuse or hazardous waste center.



This symbol indicates that you should not discard waste electrical or electronic equipment (WEEE) in the trash. For proper disposal, contact your local recycling/reuse or hazardous waste center.

Safety of Persons

- The system has its own power source (the battery). Consequently, the power outlets may be energized even if the system is disconnected from the AC power source. Dangerous voltage levels are present within the system. It should be opened exclusively by qualified service personnel.
- The system must be properly grounded at all times.
- The battery supplied with the system contains small amounts of toxic materials. To avoid accidents, the directives listed below must be observed:
 - Servicing of batteries should be performed or supervised by personnel knowledgeable about batteries and the required precautions.
 - When replacing batteries, replace with the same type and number of batteries or battery packs.
 - Do not dispose of batteries in a fire. The batteries may explode.
 - Batteries constitute a danger (electrical shock, burns). The short-circuit current may be very high.
- Precautions must be taken for all handling:
 - Wear rubber gloves and boots.
 - Do not lay tools or metal parts on top of batteries.
 - Disconnect charging source prior to connecting or disconnecting battery terminals.
 - Determine if battery is inadvertently grounded. If inadvertently grounded, remove source from ground. Contact with any part of a grounded battery can result in electrical shock. The likelihood of such shock can be reduced if such grounds are removed during installation and maintenance (applicable to equipment and remote battery supplies not having a grounded supply circuit).

Product Safety

- To connect the UPS, instructions and operation described in the manual must be followed in the indicated order.
- CAUTION - To reduce the risk of fire, the unit connects only to a circuit provided with 20 or 30 amperes maximum branch circuit overcurrent protection in accordance with the National Electric Code, ANSI/NFPA 70 (US installations only).
- Check that the indications on the rating plate correspond to your AC powered system and to the actual electrical consumption of all the equipment to be connected to the system.
- For PLUGGABLE EQUIPMENT, the socket-outlet shall be installed near the equipment and shall be easily accessible
- Never install the system near liquids or in an excessively damp environment. This equipment should only be used in a dry indoor environment.
- Never let a foreign body penetrate inside the system.
- Never block the ventilation grates of the system.
- Never expose the system to direct sunlight or source of heat.
- If the system must be stored prior to installation, storage must be in a dry place.
- The admissible storage temperature range is -25°C to +55°C without batteries, 0°C to 40°C with batteries.
- The system is not for use in a computer room AS DEFINED IN the standard for the Protection of Information Technology Equipment, ANSI/NFPA 75 (US installations only).

Special Precautions

- The unit is heavy: wear safety shoes and use vacuum lifter preferentially for handling operations.
- All handling operations will require at least two people (unpacking, lifting, installation in rack system).
- Before and after the installation, if the UPS remains de-energized for a long period, the UPS must be energized for a period of 24 hours, at least once every 6 months (for a normal storage temperature less than 25°C). This charges the battery, thus avoiding possible irreversible damage.
- During the replacement of the Battery Module, it is imperative to use the same type and number of element as the original Battery Module provided with the UPS to maintain an identical level of performance and safety. If there are any questions, don't hesitate to contact your local EATON representative.
- All repairs and service should be performed by AUTHORIZED SERVICE PERSONNEL ONLY. There are NO USER SERVICEABLE PARTS inside the UPS.
- For potential safety issue on defective UPS : DISCONNECT INTERNAL BATTERY for storage and transportation.

Table of Contents

1 Introduction	1
1.1 Introduction	1
1.2 Environmental Protection	1
2 Presentation	3
2.1 Standard Installations	3
2.2 Accessories	3
2.3 Rear Panels	4
2.4 Control Panel	5
2.5 LCD Description	6
2.6 Display Functions	7
2.7 User Settings	8
3 Installation	11
3.1 Inspecting the Equipment	11
3.2 Unpacking the Cabinet	11
3.3 Checking the Accessory Kit	12
3.4 Tower Installation	13
3.5 Rack Installation	14
3.6 Installation Requirements	16
3.7 Connecting the EBM's	17
3.8 Power Cables Connection	19
3.9 Detecting Other Accessories	19
4 Communication	21
4.1 Communication Ports	21
4.2 UPS Remote Control Functions	22
5 Operation	25
5.1 Start-up and Normal Operation	25
5.2 Starting the UPS on Battery	25
5.3 UPS Shutdown	25
6 Modes Of Operation	27
6.1 Online Mode	27
6.2 Battery Mode	27
6.3 Bypass Mode	27
6.4 Standby Mode	27
6.5 Transferring Between Modes	27
6.6 Setting High Efficiency Mode	28
6.7 Configuring Bypass Settings	28
6.8 Configuring Battery Settings	28

Table of Contents

6.9 Retrieving the Event Log	28
6.10 Retrieving the Fault Log	28
7 UPS Maintenance.....	29
7.1 Equipment Care	29
7.2 Storing the Equipment.....	29
7.3 Replacing the Batteries	29
7.4 Battery Settings Reset.....	31
7.5 Recycling The Used Equipment	33
8 Troubleshooting	35
8.1 Typical Alarms and Faults	35
8.2 Silencing the Alarm	36
8.3 Service and Support	37
8.4 Compliance Contact	37
9 Specifications	39
9.1 Model Specifications	39

Chapter 1 Introduction

1.1 Introduction

Thank you for selecting an Eaton product to protect your electrical equipment.

The Eaton 9PX range has been designed with the utmost care.

We recommend that you take the time to read this manual to take full advantage of the many features of your UPS (Uninterruptible Power System).

Before installing your Eaton 9PX, please read the information and safety instructions provided. Follow the instructions in the quick start guide and if necessary, refer to this advance user guide.

To discover the entire range of Eaton products and the options available for the 9PX range, we invite you to visit our web site at www.Eaton.com or contact your Eaton representative.

1.2 Environmental Protection

EATON has implemented an environmental-protection policy.

Products are developed according to an eco-design approach.

Substances

This product does not contain CFCs, HCFCs, or asbestos.

Packing

To improve waste treatment and facilitate recycling, separate the various packing components.

- The cardboard we use comprises over 50% of recycled cardboard.

- Sacks and bags are made of polyethylene. 
- Packing materials are recyclable and bear the appropriate identification symbol.

Table 1. Packing Material Symbols

Materials	Abbreviations	Number in the symbols
Polyethylene terephthalat	PET	01
High-density polyethylene	HDPE	02
Polyvinyl chloride	PVC	03
Low-density polyethylene	LDPE	04
Polypropylene	PP	05
Polystyrene	PS	06

Follow all local regulations for the disposal of packing materials.

End of Life

Eaton will process products at the end of their service life in compliance with local regulations. Eaton works with companies in charge of collecting and eliminating our products at the end of their service life.

Product

The product is made up of recyclable materials.

Dismantling and destruction must take place in compliance with all local regulations concerning waste. At the end of its service life, the product must be transported to a processing center for electrical and electronic waste.

Battery

The product contains lithium-ion (LFP) batteries that must be processed according to applicable local regulations concerning batteries.

The battery may be removed to comply with regulations and in view of correct disposal.

Benefits

The Eaton® 9PX uninterruptible power system (UPS) protects your sensitive electronic equipment from the most common power problems, including power failures, power sags, power surges, brownouts, line noise, high voltage spikes, frequency variations, switching transients, and harmonic distortion.

Power outages can occur when you least expect it and power quality can be erratic. These power problems have the potential to corrupt critical data, destroy unsaved work sessions, and damage hardware causing hours of lost productivity and expensive repairs.

With the Eaton 9PX, you can safely eliminate the effects of power disturbances and guard the integrity of your equipment. Providing outstanding performance and reliability, the Eaton 9PX's unique benefits include:

- True online double-conversion technology with high power density, utility frequency independence, and generator compatibility.
- Constant mode battery charger with a integrated battery management system (BMS) for temperature regulation and life cycle monitoring.
- Selectable High Efficiency mode of operation.
- Standard communication options: one RS-232 communication port, one USB communication port, and relay output contacts.
- Optional connectivity cards with enhanced communication capabilities.
- Extended runtime with up to four Extended Battery Modules (EBMs) per UPS.
- Remote On/Off control through Remote On/Off (ROO) and Remote Power Off (RPO) ports.
- Backed by worldwide agency approvals.

Chapter 2 Presentation

2.1 Standard Installations

Figure 1. UPS Dimensions

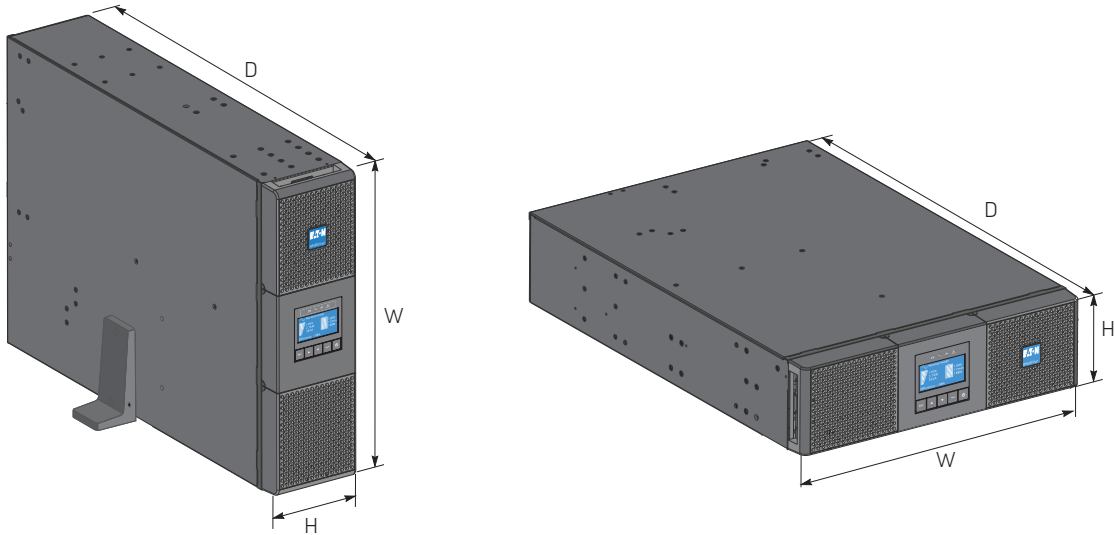

Table 2. Weights and Dimensions

Description	Weights (lb/kg)	Dimensions (inch/mm) D X W X H
9PX6K-L	81.4 / 36.9	27.0 x 17.3 x 5.1 / 685 x 440 x 130
9PXEBM192RT-L	78.9 / 35.8	25.4 x 17.2 x 3.4 / 645 x 438 x 85.3

2.2 Accessories

Table 3. UPS Accessories

Part number	Description
9PXEBM192RT-L	Extended Battery Module
9RK	4– post Rack Kit 9PX
RK2PC	2–post Rack Kit 9PX
Network-M2	Network Card
Network-M3	Network Card
INDGW-M2	Industrial Gateway Card (Modbus TCP / RTU)
Relay-MS	Relay Card

Table 3. UPS Accessories (Continued)

Part number	Description
EMPDT1H1C2	Environmental Monitoring Probe Gen 2 (Compatible with NETWORK-M2 only)
MBP6K208	Hotswap MBP 6000 208
9PXTFMR5	5kVA Transformer
9XPPDM1	6kVA PPDM (Type 1)
9XPPDM2	6kVA PPDM (Type 2)
EBMCBL192-L	1.8m cable 192V EBM

2.3 Rear Panels

Figure 2. 9PX6K-L

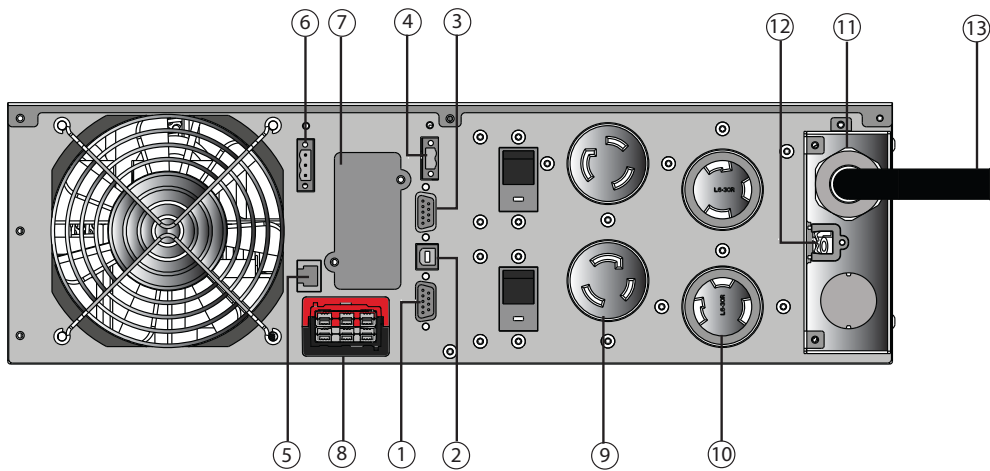

- ① RS232 communication port
- ② USB communication port
- ③ Dry (relay)contacts communication port
- ④ Connector for RPO (Remote On / Off) control
- ⑤ Connector for communicating with an additional battery module
- ⑥ Connector for RPO (Remote Power Off) control
- ⑦ Slot for optional communication card
- ⑧ Connector for additional battery module
- ⑨ (2) L6-20R outlets
- ⑩ (2) L6-30R outlets
- ⑪ Input / Output terminal blocks
- ⑫ Connector for Hotswap / MBP detection
- ⑬ Input power cable with L6-30 plug

Figure 3. 9PXEBM192RT-L

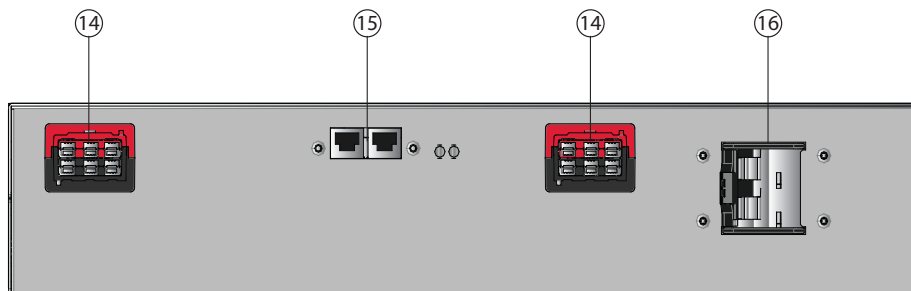

⑭ Connectors for battery modules (to the UPS or to the other battery modules)





⑮ Connector for communicating with an additional battery module

⑯ Battery breaker

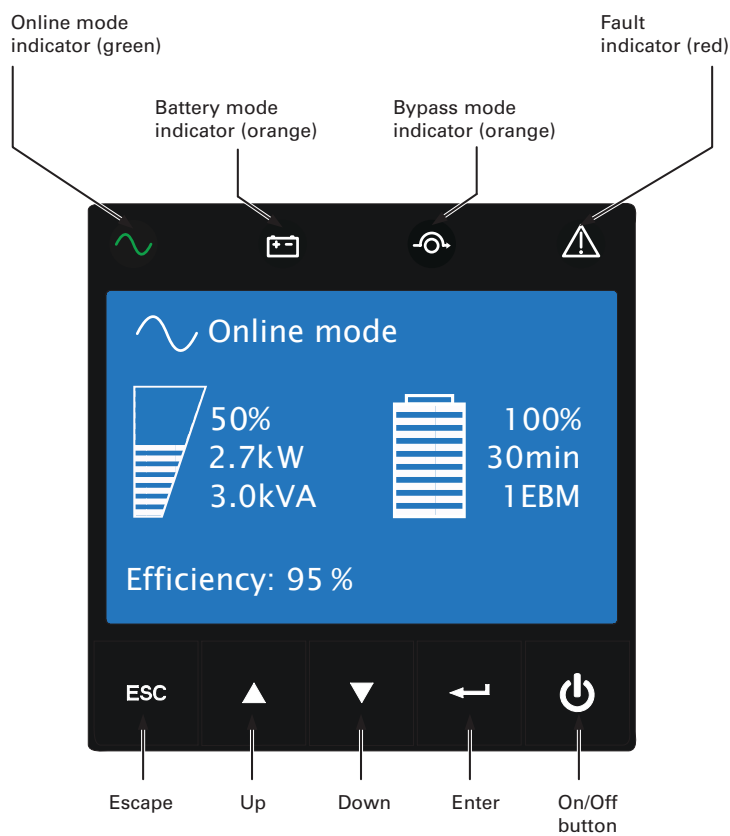
2.4 Control Panel

The UPS has a five-button graphical LCD. It provides useful information about the UPS itself, load status, events, measurements and settings.



Indicator	Status	Description
 Green	On	The UPS is operating normally on Online or on High Efficiency mode.
 Orange	On	The UPS is on Battery mode.
 Orange	On	The UPS is on Bypass mode.
 Red	On	The UPS has an active alarm or fault.

2.5 LCD Description

Figure 4. LCD Description

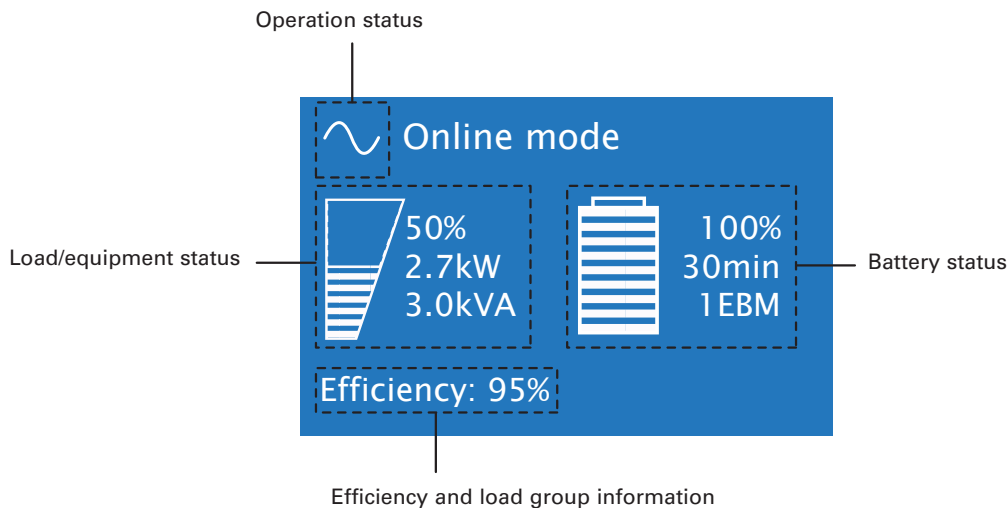

The following table describes the status information provided by the UPS

Note: If other indicator appears, see the troubleshooting for additional information.

Table 4. LCD Operating Status







Operation status	Cause	Description
Standby mode 	The UPS is Off, waiting for startup command from user.	Equipment is not powered until  button is pressed.
Online mode 	The UPS is operating normally.	The UPS is powering and protecting the equipment.

Table 4. LCD Operating Status (Continued)

Operation status	Cause	Description
Battery mode 	A utility failure has occurred and the UPS is on Battery mode.	The UPS is powering the equipment with the battery power. Prepare your equipment for shutdown.
End of backup time 	The UPS is on Battery mode and the battery is running low.	Low Battery Warning settings: [Capacity] [0%] ... [100%] The alarm triggers when the set percentage of battery capacity or remaining back-up time is reached.
High Efficiency mode 	The UPS is operating on High Efficiency mode.	The UPS is powering and protecting the equipment
Bypass mode 	An overload or a fault has occurred, or a command has been received, and the UPS is in Bypass mode.	Equipment is powered but not protected by the UPS.

2.6 Display Functions

Press the (←) button to activate the menu options. use the two middle buttons (▲ and ▼) to scroll through the menu structure. Press the (←) button to select an option. Press the ESC button to cancel or return to the previous menu.

Table 5. Display Functions

Main menu	Submenu	Display information or Menu function
Measurements		[Load] [Input] [Bypass] [Output Efficiency] [Battery] [DC Bus] [Average Power Usage] [Cumulat.Power Usage] [BMS Information]
Control	Go to Bypass	Transfers the UPS on Bypass mode
	Start battery test	Starts a manual battery test
	Reset fault state	Clears active fault
	Restore factory set	Returns all settings to original values
	Reset average power	Clears average power usage measurement
	Reset cumul. power	Clears cumulated power usage measurement
	Dry contacts test	Tests dry contact relay outputs
BMS Auto Setup	UPS will auto detect the EBM quantities only when the UPS powered on for the first time. If the quantity of EBMs is reduced, UPS will report BMS comm. loss. If the quantity is increased, UPS cannot actively identify it. In those time, the user can select "BMS auto setup" to manually refresh the battery quantity.	

Table 5. Display Functions (Continued)

Main menu	Submenu	Display information or Menu function
Settings	Local settings	Sets product general parameters
	In/out settings	Sets Input and Output parameters
	On/Off settings	Sets On/Off conditions
	Battery settings	Sets battery configuration
Event Log	Event filter	Selects faults, alarms and/or events to display
	Event list	Displays the events stored
	Reset fault list	Clears events
Fault log	Fault list	Displays the faults stored
	Reset fault list	Clears faults
Identification		[Product type/model] / [Part/Serial number] / [UPS/NMC firmware] / [Com card IPv4], [Com card IPv6], [Com card MAC]
Registration		Links to Eaton registration website

2.7 User Settings

The following table displays the options that can be changed by the user.

Table 6. User Settings

	Submenu	Available Settings	Default settings
Local Settings	Language	[English] [Français] [Deutsch] [Español] [Русский] [Simplified Chinese] Menus, status, notices and alarms, UPS fault, Event Log data and settings are in all supported languages.	[English] User selectable when UPS is powered for the first time.
	Date/ time	Format: [International] [US]	[US]
	LCD	Modify LCD screen brightness and contrast to be adapted to room light conditions.	
	Audible alarm	Mode: [Enabled] [Disabled on battery] [Always disabled] Enable or disable the buzzer if an alarm occurs. Level: [High] [Low]	[Enabled] [High]
	Protected Access	[Enabled] [Disabled] Usage of password to access to Control, Settings, Event logs Fault logs menus.	[Disabled]
In/Out settings	Output voltage	[200V] [208V] [220V] [230V] [240V]	[208V]
	Output frequency	Frequency converter: [Enabled] [Disabled] Frequency settable in frequency converter mode	[Disabled]
	Output mode	[Industrial] [Network] Set UPS behavior regarding transfer on Bypass	[Network]
	Input volt hysteresis	Sets input voltage hysteresis from [1] to [10V]	[10V]

Table 6. User Settings (Continued)

	Submenu	Available Settings	Default settings
	High Efficiency mode	[Enabled] [Disabled] Power the output from Bypass for high efficiency	[Disabled]
	Bypass transfer	[Transfer if BP AC NOK] [Enabled] [Disabled] Allow transfer on Bypass out of tolerance	[Disabled]
	Overload prealarm	[10%] ... [102%] Load % when overload alarm occurs	[102%]
	Redundancy mode	[Unitary UPS] [Hot Standby] Force slew rate value to 0.5Hz/s	Unitary UPS
On/Off Settings	Cold Start	[Enabled] [Disabled] Authorize the product to start on battery power.	[Enabled]
	Forced reboot	[Enabled] [Disabled] If mains recover during a shutdown sequence: If set to Enabled, shutdown sequence will complete and wait 10 seconds prior to restart, If set to Disabled, shutdown sequence will not complete and restart will occur immediately.	[Enabled]
	Auto restart	[Enabled] [Disabled] Authorize the product to restart automatically when mains recovers after a complete battery discharge.	[Enabled]
	Auto start	[Enabled] [Disabled] The UPS automatically starts up as soon as mains power is available (no need to press the  button).	[Disabled]
	Energy Saving	[Disabled] [100W] ... [1000W] If Enabled, UPS will shutdown after 5 min. of back-up time, if load is less than threshold.	[Disabled]
	Sleep mode	[Enabled] [Disabled] If Disabled, LCD and communication will turn OFF immediately after UPS is OFF. If Enabled, LCD and communication stays ON 1h30 min after UPS is OFF.	[Enabled]
	Remote Command	[Enabled] [Disabled] If Enabled, shutdown or restart commands from software are authorized.	[Enabled]
	Bypass standby	[Enabled] [Disabled] Define if output is powered from Bypass in Standby mode.	[Disabled]
Battery settings	Low battery warning	[Capacity] [0%] ... [100%] The alarm triggers when the set percentage of battery capacity or remaining back-up time is reached.	[20%]
	Restart bat. level	[0%] ... [100%] If set, automatic restart will occur only when percentage of battery charge is reached.	[0%]

Chapter 3 Installation

3.1 Inspecting the Equipment

If any equipment has been damaged during shipment, keep the shipping cartons and packing materials for the carrier or place of purchase and file a claim for shipping damage. If you discover damage after acceptance, file a claim for concealed damage.

To file a claim for shipping damage or concealed damage:

1. File with the carrier within 15 days of receipt of the equipment;
2. Send a copy of the damage claim within 15 days to your service representative.



IMPORTANT

Check the battery recharge date on the shipping carton label. If the date has passed and the batteries were never recharged, do not use the UPS. Contact your service representative.

3.2 Unpacking the Cabinet

Unpacking the cabinet in a low-temperature environment may cause condensation to occur in and on the cabinet. Do not install the cabinet until the inside and outside of the cabinet are absolutely dry (hazard of electric shock).

The cabinet is heavy. Follow Special precautions provided and on the carton

Unpack the equipment and remove all the packing materials and shipping carton.



NOTE

Do not lift the UPS or EBM from the front panel.

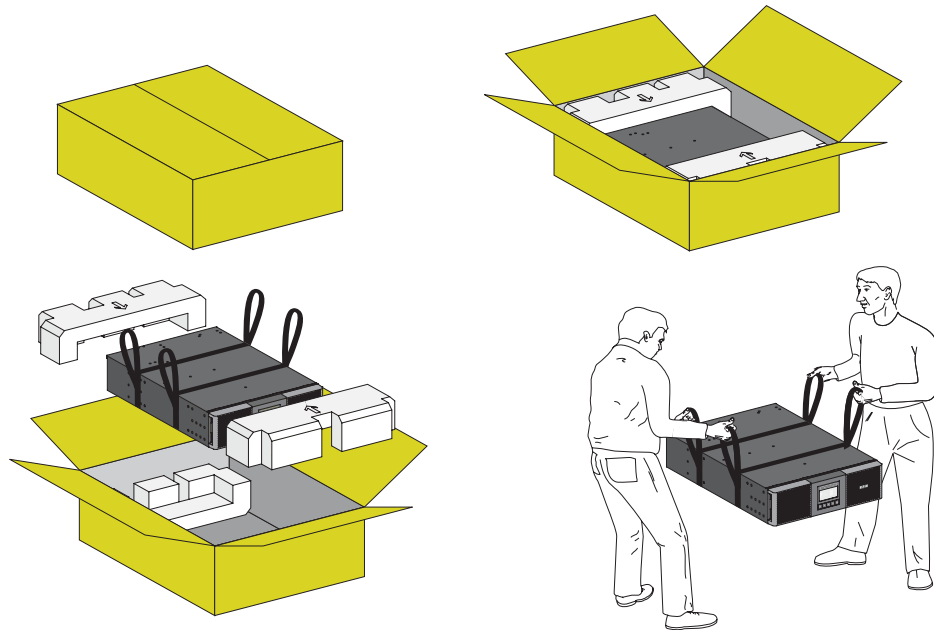

Checking the Accessory Kit

Discard or recycle the packaging in a responsible manner, or store it for future use. Place the cabinet in a protected area that has adequate airflow and is free of humidity, flammable gas, and corrosion.

Packing materials must be disposed of in compliance with all local regulations concerning waste. Recycling symbols are printed on the packing materials to facilitate sorting.

3.3 Checking the Accessory Kit

Verify that the following additional items are included with the UPS:

Figure 5. 9PX6K-L

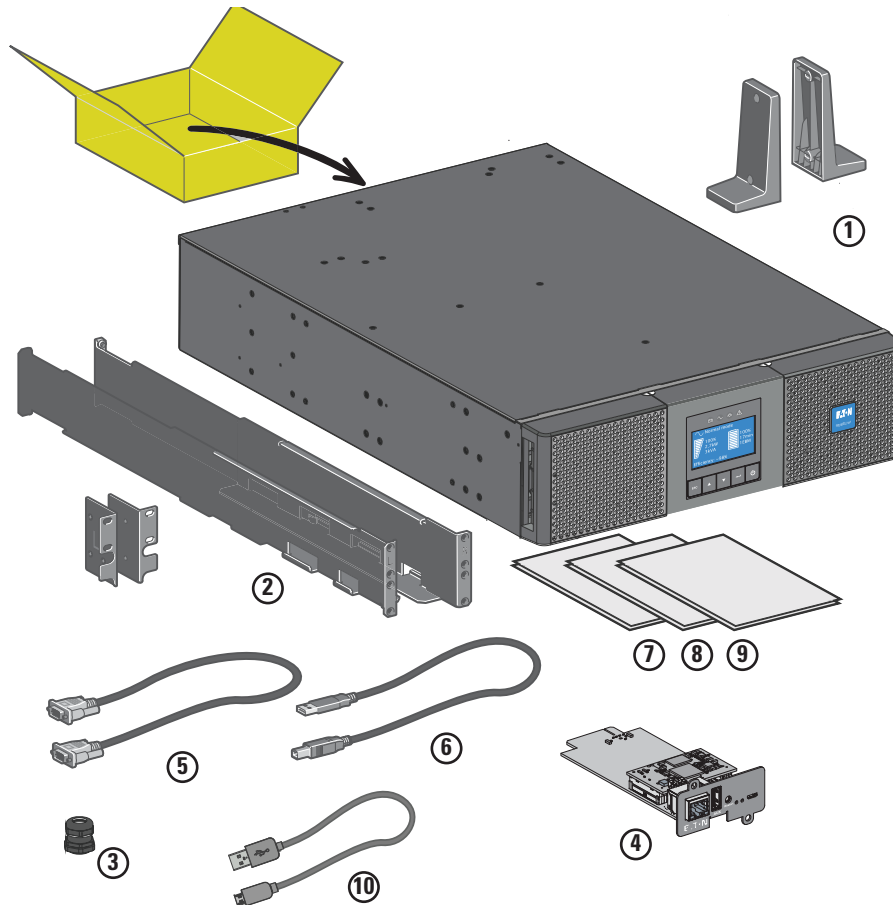

- ① (2) Tower stands
- ② Rack kit for 19-inch enclosures
- ③ Cable gland for Output connection
additional cable gland for Input
- ④ Network card communication card
- ⑤ RS232 communication cable
- ⑥ USB communication cable

- ⑦ Safety instructions
- ⑧ Quick Start Guide
- ⑨ NMC Card User Guide
- ⑩ NMC Card data cable

Figure 6. 9PXEBM192RT-L

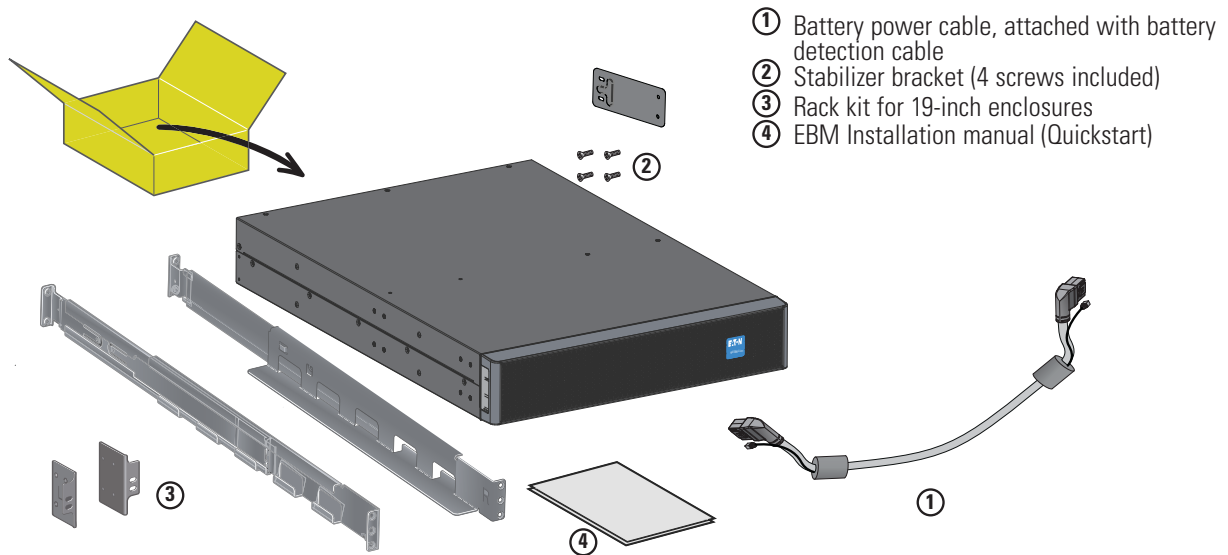

NOTE 1 Discard the EBM user's guide if you are installing the EBM with a new UPS at the same time.



NOTE 2 Use the UPS user's guide to install both the UPS and the EBM.

NOTE 3 If you ordered other UPS accessories, refer to specific user manuals to check the packing contents.

3.4 Tower Installation

Tip If you ordered other UPS accessories, refer to specific user manuals to check the tower installation with the UPS.

To install the cabinet:

1. Place the UPS on a flat, stable surface in its final location.
2. Always keep 6" or 150 mm of free space behind the UPS rear panel for ventilation.
3. If installing additional cabinets, place them next to the UPS in their final location.

Figure 7. Tower Installation

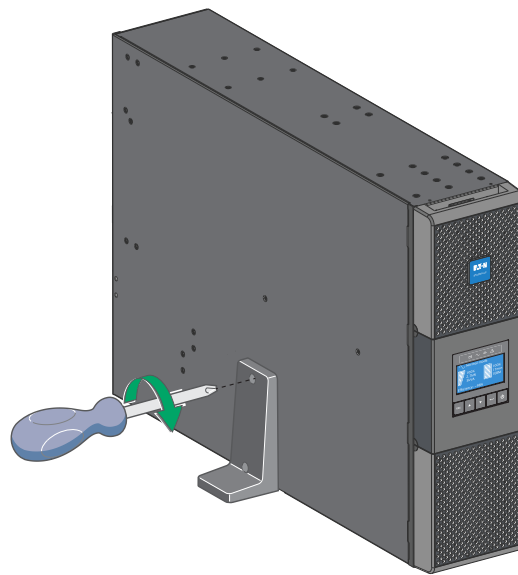

- Adjustment of the orientation of the LCD panel and of the logo.
- Adjustment of the angle of vision of the LCD panel.

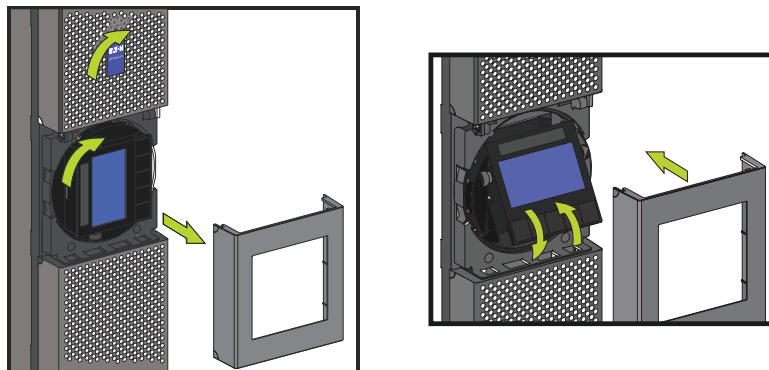

3.5 Rack Installation



NOTE

It is recommended that the UPS internal battery pack be removed before attempting to install the UPS in a Rackmount configuration. Follow Steps 1–6 on how to remove the battery pack from the UPS.

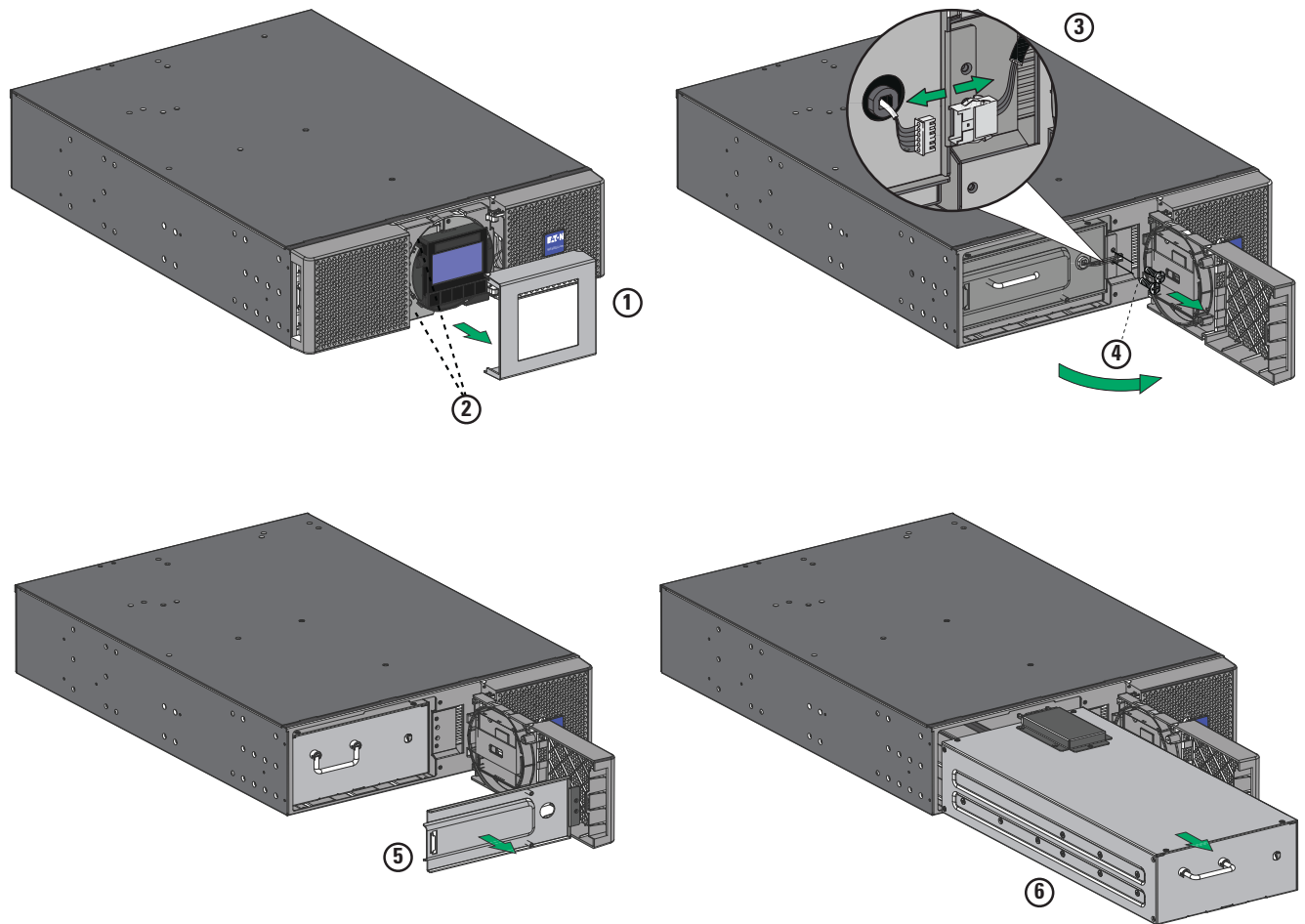
Figure 8. Removal of the Battery Pack

To remove the battery pack:

1. Remove the center cover of the front panel.
2. Remove the two screws to open the left side of the front panel.
3. Disconnect the BMS battery connector.
A ribbon cable connects the LCD control panel to the UPS. Do not pull on the cable or disconnect it.
4. Remove the two screws that hold the metal protection cover in place.
5. Carefully guide the BMS cable through the hole in the metal protection cover and remove.
6. Pull out the handle of the battery pack, and slide the pack out slowly on to a flat and stable surface. Use two hands to support the battery pack.

Installing the UPS on the Rails

Follow steps 1 to 5 for module mounting on the rails.

Figure 9. UPS Rackmount Installation

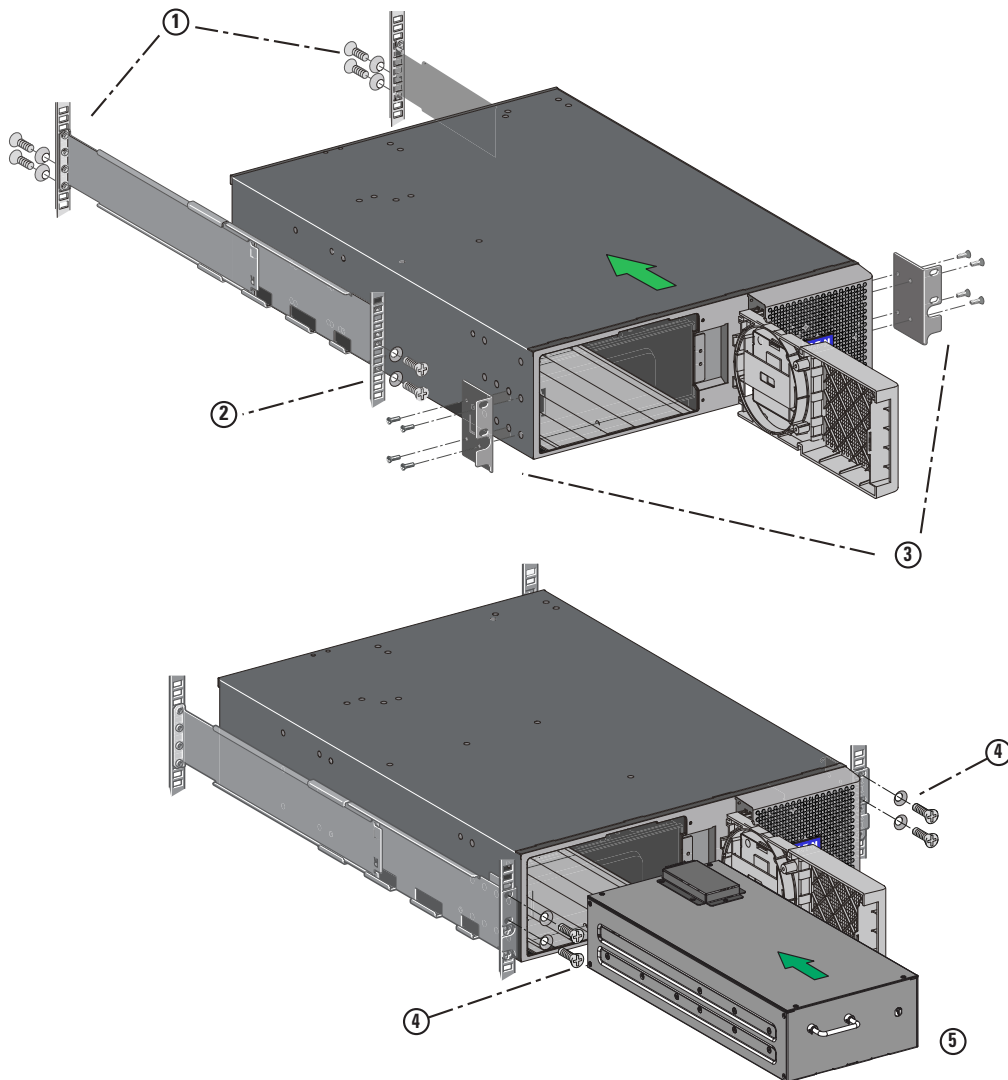

Screw back in the metal protection cover, connect the BMS connector together and install the screws for the front panel, then clip the center cover.

The rails and necessary hardware are supplied by EATON.

3.6 Installation Requirements

Recommended protective devices and cable cross-sections.

1. Recommended upstream protection

UPS Power Rating	Upstream circuit breaker
6000VA	D curve — 30A

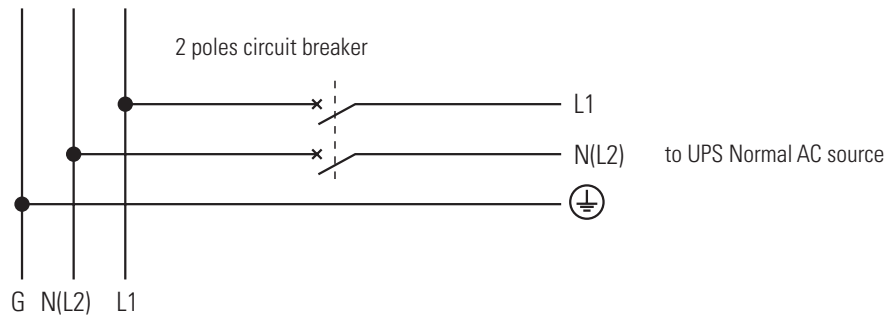

2. Recommended cable cross-sections

Terminal Position	Wire Function	Terminal Wire Size Rating	Minimum Input Wire Size	Tightening Torque
L1	Phase	4-16 mm ² (12-6 AWG)	6 mm ² (10 AWG) 105° C 10 mm ² (8 AWG) 75°C Min 10 mm ² for ground	10 lb in / 1.13 Nm
N (L2)	Neutral (Phase)			
	Ground			

3.7 Connecting the EBM's

CAUTION

A small amount of arcing may occur when connecting an EBM to the UPS. This is normal and will not harm personnel. Insert the EBM cable into the UPS battery connector quickly and firmly.

1. Plug the EBM power cable(s) into the battery connector(s). Up to 4 EBMs may be connected to the UPS.
2. Verify that the EBM connections are tight and that adequate bend radius and strain relief exist for each cable.
3. Connect the battery detection cable(s) to the connector of the UPS and of the EBM(s).



NOTE

The EBM communication wiring connections are directional and must be connected in the correct sequence to ensure proper detection, regulation and lifecycle monitoring of the integrated battery management system (BMS). When multiple EBMs are used in parallel, or when a new EBM is connected, please note that the voltage difference between the different EBM's should not be too large, less than 5V is recommended.

4. Turn the DC breaker on each EBM to the "ON" position.

Figure 10. Rack mount EBM Connection

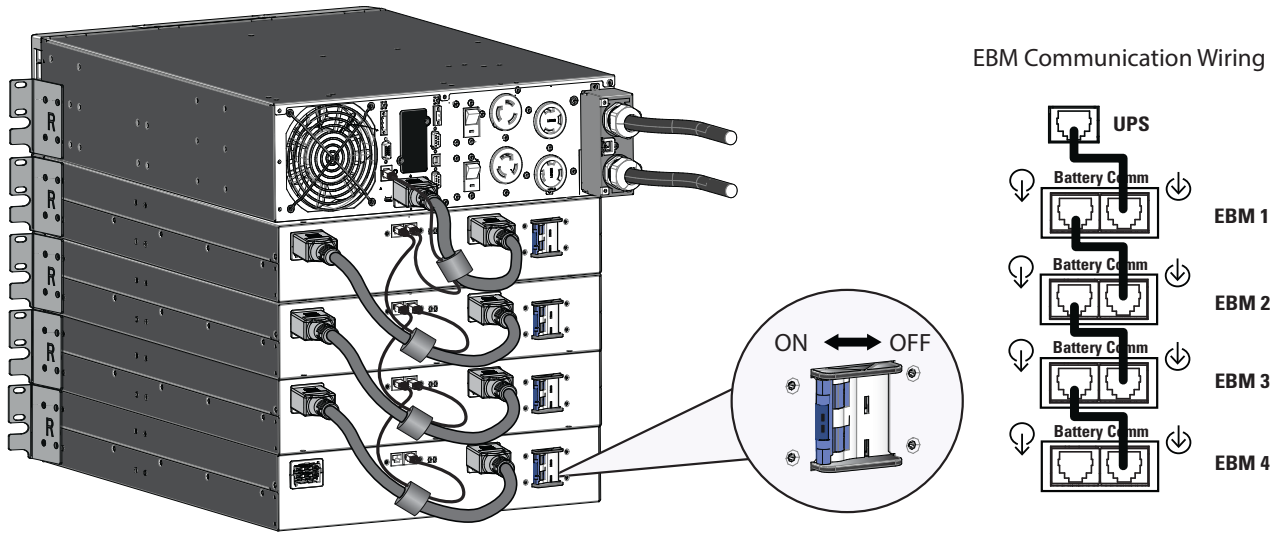
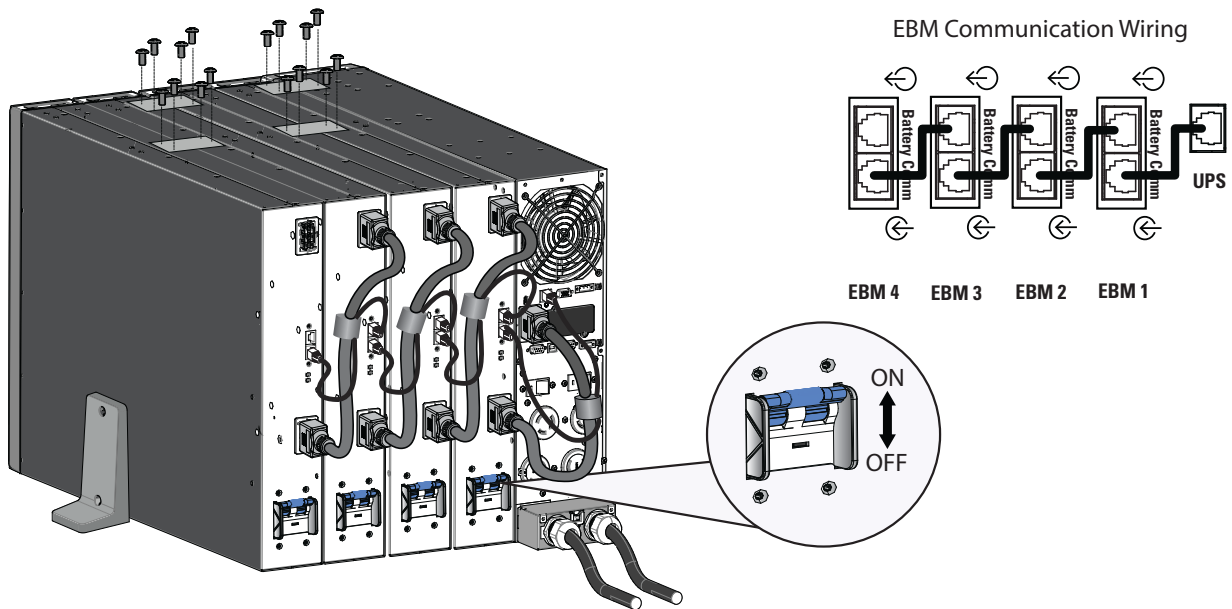

Figure 11. Tower EBM Connection



3.8 Power Cables Connection

Access to Terminal Blocks

1. Remove the terminal blocks cover (one screw)
2. Punch the knockouts and insert the cables/conduits inside

CAUTION

High leakage current. Earth connection essential before connecting supply.



NOTE

The L6-30P input power cable is attached by Eaton.

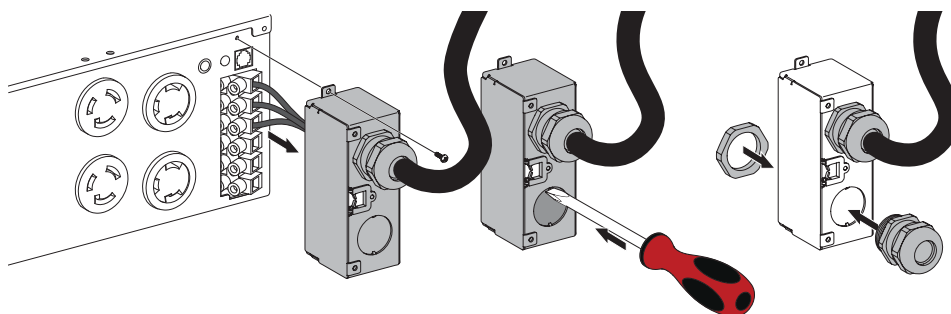

WARNING

This type of connection must be carried out by qualified electrical personnel.

Before carrying out any connection, check that the upstream protection device (Normal AC source) is open "O" (Off). Always connect the ground wire first

If you ordered a HotSwap MBP or a PPDM, refer to the specific user manual to check the terminal blocks connection of the UPS with this accessory.

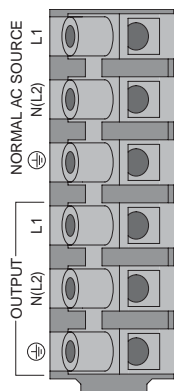

- ① Insert the Normal AC cable through the cable gland.
- ② Connect the three cables to the Normal AC source terminal blocks.
- ③ Insert the Output cable through the cable gland.
- ④ Connect the three cables to the Output terminal blocks.
- ⑤ Put back and secure the terminal blocks cover with the screw.
- ⑥ Tighten the cable glands.

3.9 Detecting Other Accessories

Tip If you ordered other UPS accessories, refer to specific user manuals to check the connection to the UPS.

Detecting Other Accessories

Chapter 4 Communication

4.1 Communication Ports

Figure 12. Communication Port Information

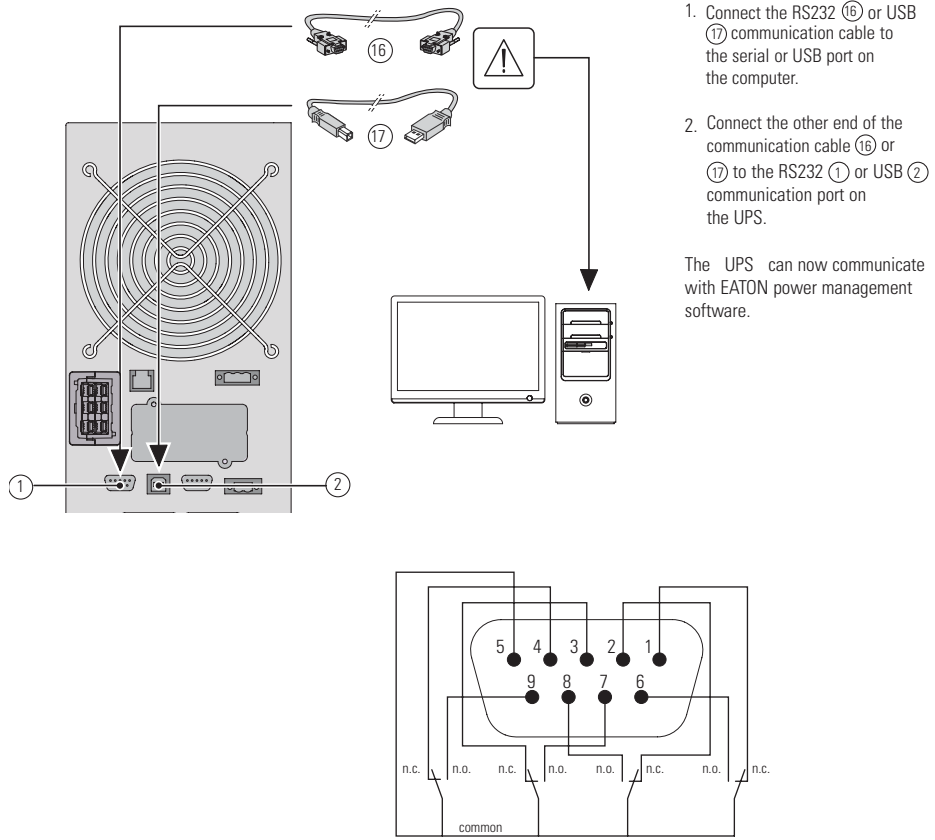

Status active information: (if contact between pin and common is closed)

- Pin 1: not on bypass
- Pin 2: load not protected
- Pin 3: not low battery
- Pin 4: not on battery
- Pin 5: user common
- Pin 6: on bypass
- Pin 7: low battery
- Pin 8: load protected
- Pin 9: on battery
- n.o.: contact normally open
- n.c.: contact normally closed

**IMPORTANT**



The relay output contacts must not be connected to any utility connected circuits. Reinforced insulation to the utility is required. The relay output contacts have a maximum rating of 250 Vac/5A.

4.2 UPS Remote Control Functions

Remote ON/Off

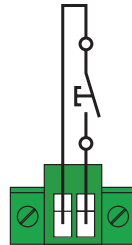
Figure 13. Normally Open ROO



- Remote On/Off allows remote action of  button to switch On/Off the UPS.
- When contact changes from open to closed, the UPS is switched-on (or stays On).
- When contact changes from closed to open, the UPS is switched-off (or stays Off).
- On/Off control via  button has priority over the remote control.

Remote Power Off

RPO is used to shutdown the UPS remotely when the contact is open. This feature can be used for shutting down the load and the UPS by thermal relay, for instance in the event of room over temperature. When RPO is activated, the UPS shuts down the output and all its power converters immediately. The UPS remains on to alarm the fault. The RPO circuit is an IEC 60950 safety extra low voltage (SELV) circuit. This circuit must be separated from any hazardous voltage circuits by reinforced insulation.

- The RPO must not be connected to any utility connected circuits. Reinforced insulation to the utility is required. The RPO switch must have a minimum rating of 27 Vdc and 20 mA and be a dedicated latching-type switch not tied into any other circuit. The RPO signal must remain active for at least 250 ms for proper operation.
- To ensure the UPS stops supplying power to the load during any mode of operation, the input power must be disconnected from the UPS when the Remote Power Off function is activated.

Leave the RPO connector installed in the RPO port on the UPS even if the RPO function is not needed.

RPO connections:

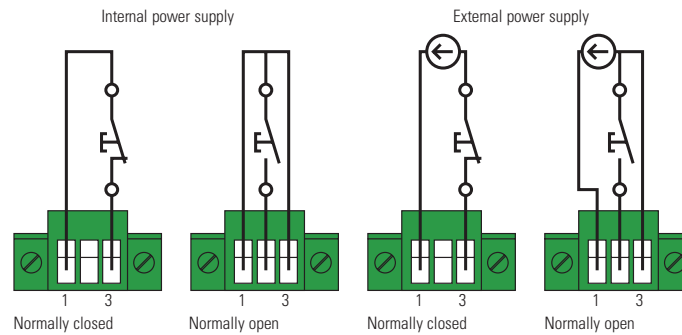

Terminal wire size rating is 0.32-4 mm² (22-12 AWG).
Suggested wire size is 0.82 mm² (18 AWG).

Remote Control Connection and Test

1. Check the UPS is shut down and the electrical supply network disconnected.
2. Remove RPO connector from the UPS by unfitting the screws.
3. Connect a normally closed volt-free contact between the two pins of connector.

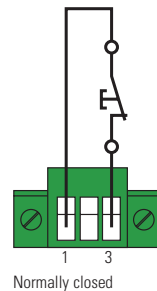

Contact open: shut down of UPS
To return to normal operation, deactivate the external remote shut down contact and restart the UPS from the front panel.

4. Plug the RPO connector into the back of the UPS and fix the screws.
5. Connect and restart the UPS according to the previously described procedures.
6. Activate the external remote shut down contact to test the function. Always test the RPO function before applying your critical load to avoid accidental load loss.

Connectivity Cards

Connectivity cards allow the UPS to communicate in a variety of networking environments and with different types of devices. The 9PX models have one available communication bay for the following connectivity cards:

- **Network-M2 card** — has SNMP and HTTP capabilities as well as monitoring through a Web browser interface; connects to a Gigabit Ethernet network. In addition, a Environmental Monitoring Probe can be attached to obtain humidity, temperature, smoke alarm, and security information.
- **INDGW-M2 card**- has SNMP and HTTP capabilities and a Modbus to facilitate remote monitoring of the UPS system through any Building Management System.
- **Relay-MS card**- has isolated dry contact (Form-C) relay outputs for UPS status: Utility failure, Battery low, UPS alarm/OK, or on Bypass.

Figure 14. Connectivity Card Options

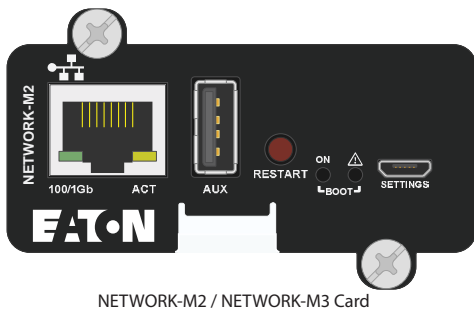

NETWORK-M2 / NETWORK-M3 Card

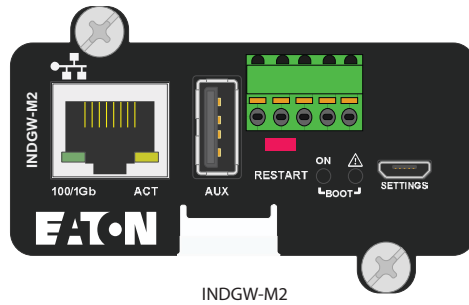

INDGW-M2



Industrial Relay Card



Relay-MS Card

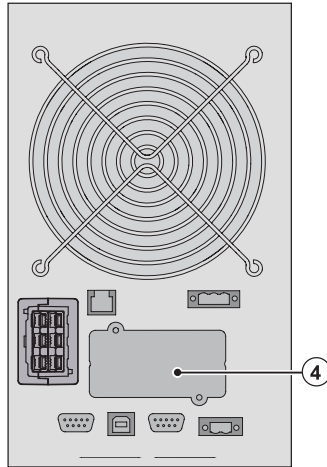

It is not necessary to shutdown the UPS before installing a communication card.

1. Remove the slot cover ④ secured by screws.
2. Insert the communication card in the slot.
3. Secure the card cover with the 2 screws.

Eaton Intelligent Power Software suite

Eaton Intelligent Power Software suite is available from Eaton.com. Eaton Software suite provides up-to-date graphics of UPS power and system data and power flow. It also gives you a complete record of critical power events, and it notifies you of important UPS or power information. If there is a power outage and the 9PX UPS battery power becomes low, Eaton Software suite can automatically shut down your computer system to protect your data before the UPS shutdown occurs.





Chapter 5 Operation

5.1 Start-up and Normal Operation

**NOTE**

If you ordered a HotSwap MBP or a PPDM, refer to the specific user manual to check the startup sequence of the UPS with this accessory.

To start the UPS:

1. Verify that the internal batteries are connected. See section .
2. If optional EBMs are installed, verify that the EBM are connected to the UPS. See section [3.7 Connecting the EBM's](#).
3. Verify that the UPS power cord is plugged in.
4. The UPS front panel display illuminates and shows EATON logo.
5. Verify that the UPS status screen shows .
6. Press the  button on the UPS front panel for at least 3 seconds. The UPS front panel display changes status to "UPS starting...".
7. Check the UPS front panel display for active alarms or notices. Resolve any active alarms before continuing. See section [8.1 Typical Alarms and Faults](#). If the  indicator is on, do not proceed until all alarms are clear. Check the UPS status from the front panel to view the active alarms. Correct the alarms and restart if necessary.
8. Verify that the  indicator illuminates solid, indicating that the UPS is operating normally and any loads are powered and protected. The UPS should be in Online mode.

5.2 Starting the UPS on Battery

Before using this feature, the UPS must have been powered by utility power with output enabled at least once. Battery start can be disabled. See Coldstart setting in [2.7 User Settings](#) .

To Start the UPS on battery:

1. Press the  button on the UPS front panel until the UPS front panel display illuminates and shows a status of "UPS starting...".

The UPS cycles through Standby mode to Battery mode. The  indicator illuminates solid.

The UPS supplies power to your equipment.

2. Check the UPS front panel display for active alarms or notices. Resolve any active alarms before continuing. See [8.1 Typical Alarms and Faults](#).

Check the UPS status from the front panel to view the active alarms. Correct the alarms and restart if necessary.

5.3 UPS Shutdown

To shut down the UPS:

1. Press the  button on the front panel for three seconds. A confirmation message will appear. When confirmed, the UPS starts to beep and shows a status of "UPS shutting OFF...". The UPS then transfers to Standby mode.
2. Set the upstream circuit breaker (not provided) to the "O" position (Off) to switch off the utility power.

Chapter 6 Modes Of Operation

6.1 Online Mode

During Online mode, the  indicator illuminates solid and the UPS is powered from the utility. The UPS monitors and charges the batteries as needed and provides filtered power protection to your equipment. Optional High Efficiency and Energy Saving settings minimize heat contribution to the rack environment. See [2.7 User Settings](#).

6.2 Battery Mode

When the UPS is operating during a power outage, the alarm beeps once every ten seconds and the  indicator illuminates solid. The necessary energy is provided by the battery. When the utility power returns, the UPS transfers to Online mode operation while the battery recharges. If battery capacity becomes low while on Battery mode, the audible alarm beeps once every 3 seconds. This warning is approximate, and the actual time to shutdown may vary significantly. Shutdown all applications on the connected equipment because automatic UPS shutdown is imminent. When utility power is restored after the UPS shuts down, the UPS automatically restarts.

6.3 Bypass Mode

In the event of a UPS overload or internal failure, the UPS transfers your equipment to utility power. Battery mode is not available and your equipment is not protected; however, the utility power continues to be passively filtered by the UPS. The  indicator illuminates. Depending on overload conditions, the UPS remains in Bypass mode for at least 5 seconds and will stay in this mode if three transfers to Bypass occur within 20 minutes.

The UPS transfers to Bypass mode when:

- the user activates Bypass mode through the front panel.
- the UPS detects an internal failure.
- the UPS has an overtemperature condition.
- the UPS has an overload condition listed in [9.1 Model Specifications](#).

The UPS shuts down after a specified delay for overload conditions listed in [9.1 Model Specifications](#). The UPS remains on to alarm the fault.

6.4 Standby Mode

When the UPS is turned-off and remains connected to AC source, the UPS is in Standby mode.

Depending if Bypass Standby setting is enabled, the output is powered but not protected.

The battery recharges when necessary and the communication ports are powered.

6.5 Transferring Between Modes

From Online (or Battery) to Bypass mode. Press any button to activate the menu options, then select Control and Go to Bypass.

From Bypass to Online (or Battery) mode. Press any button to activate the menu options, then select Control and Go back normal.

6.6 Setting High Efficiency Mode

In High Efficiency mode, the UPS operates normally on Bypass and transfers to Online (or Battery) mode in less than 10 ms when utility fails. Transfers to High Efficiency mode will be active after 5 minutes of Bypass voltage monitoring: if Bypass quality is not in tolerance, then the UPS will remain in Online mode.

Eaton recommends to use the HE mode only to protect IT equipment.

To set the High Efficiency mode:

1. Select Settings, In/Out settings, and High Efficiency mode.
2. Select Enabled and Enter to confirm.
3. The UPS transfers to High Efficiency mode after 5 minutes.

6.7 Configuring Bypass Settings

The following settings are available for configuring Bypass operation.

Bypass Transfer out of tolerance

1. Press any button to activate the menu options, then select Settings, Output settings, and Bypass transfer.
2. Select Enabled or Disabled for BP AC NOK, and Enter to confirm. If Enabled, the UPS transfers to Bypass even if Bypass AC source is out of tolerance, depending on output mode. If Disabled, the UPS output is shutdown.

6.8 Configuring Battery Settings

Low battery warning

During discharge, the low battery alarm is activated if the battery capacity goes below 20%. This threshold can be modified.

6.9 Retrieving the Event Log

To retrieve the Event log through the display:

1. Press any button to activate the menu options, then select Event log.
2. Scroll through the listed events.

6.10 Retrieving the Fault Log

To retrieve the Fault log through the display:

1. Press any button to activate the menu options, then select Fault log.
2. Scroll through the listed faults.

Chapter 7 UPS Maintenance

7.1 Equipment Care

For the best preventive maintenance, keep the area around the equipment clean and dust free. If the atmosphere is very dusty, clean the outside of the system with a vacuum cleaner. For full battery life, keep the equipment at an ambient temperature of 25°C (77°F).

If the UPS requires any type of transportation, verify that the UPS is disconnected and turned off and then disconnect the UPS internal battery connector .

If the UPS requires any type of transportation, verify that the UPS is disconnected and turned off. The batteries are rated for a 8 year service life. The length of service life varies, depending on the frequency of usage and ambient temperature. Batteries used beyond expected service life will often have severely reduced runtimes.

7.2 Storing the Equipment

If you store the equipment for a long period, recharge the battery every 6 months by connecting the UPS to utility power. The internal batteries charge to 90% capacity in less than 4.7 hours. However, Eaton recommends that the batteries charge for 48 hours after long-term storage. Check the battery recharge date on the shipping carton label. If the date has passed and the batteries were never recharged, do not use them. Contact your service representative.

7.3 Replacing the Batteries

CAUTION

- DO NOT DISCONNECT the batteries while the UPS is in Battery mode.
 - The internal battery is heavy. Use caution when handling the heavy batteries.
-

Eaton Lithium-ion UPS batteries have an expected life span of 8 years. After 8 years of operation, the UPS will provide a battery replacement notification reminding you that your batteries are nearing the end of their useful life. You should take proactive steps to ensure you replace your batteries for optimal operation and reliability. Contact your service representative to order new batteries.



Batteries can be replaced easily without turning off the UPS or disconnecting the load. If you prefer to remove input power to change the batteries, see [5.3 UPS Shutdown](#) .

Consider all warnings, cautions, and notes before replacing batteries.

- Servicing should be performed by qualified service personnel knowledgeable of batteries and required precautions. Keep unauthorized personnel away from batteries.
- Batteries can present a risk of electrical shock or burn from high short circuit current. Observe the following precautions:
 1. Remove watches, rings, or other metal objects,

Replacing the Batteries

2. Use tools with insulated handles,
 3. Do not lay tools or metal parts on top of batteries,
 4. Wear rubber gloves and boots.
- When replacing batteries, replace with the same type and number of batteries or battery packs. Contact your service representative to order new batteries.
 - Proper disposal of batteries is required. Refer to your local codes for disposal requirements.
 - Never dispose of batteries in a fire. Batteries may explode when exposed to flame.
 - Do not open or mutilate the battery or batteries. Released electrolyte is harmful to the skin and eyes and may be extremely toxic.
 - Determine if the battery is inadvertently grounded. If inadvertently grounded, remove source from ground. Contact with any part of a grounded battery can result in electrical shock. The likelihood of such shock can be reduced if such grounds are removed during installation and maintenance (applicable to equipment and remote battery supplies not having a grounded supply circuit).
 - **ELECTRIC ENERGY HAZARD.** Do not attempt to alter any battery wiring or connectors. Attempting to alter wiring can cause injury.

Figure 15. Internal Battery Pack Replacement

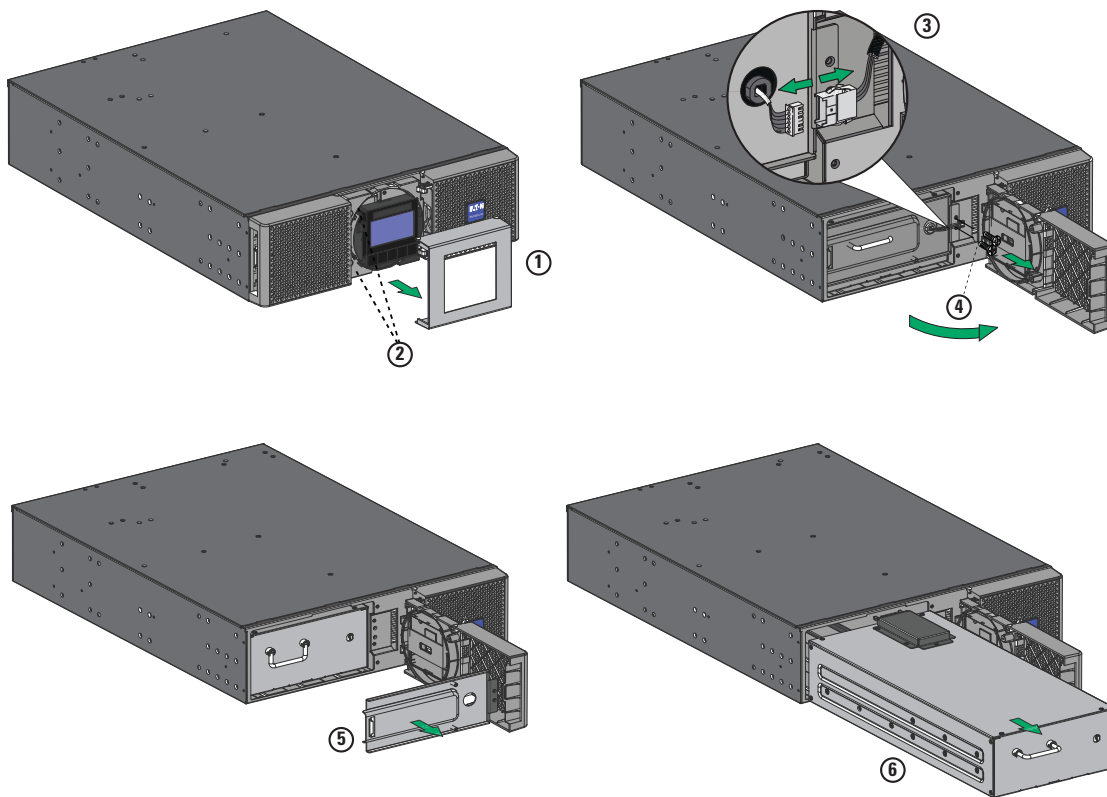

To replace the battery pack:

1. Remove the center cover of the front panel.

2. Remove the two screws to open the left side of the front panel.
3. Disconnect the battery connectors.
A ribbon cable connects the LCD control panel to the UPS. Do not pull on the cable or disconnect it.
4. Remove the two screws that hold the battery protection cover in place.
5. Carefully guide the BMS cable through the hole in the metal protection cover and remove.
6. Pull out the handle of the battery pack, and slide the pack out slowly on to a flat and stable surface. Use two hands to support the battery pack. See [7.5 Recycling The Used Equipment](#) for proper disposal.
7. Verify that the replacement batteries have the same rating as the batteries being replaced.
8. Put the new battery pack into the UPS. Push the battery pack firmly,
9. Guide the BMS cable through the hole in the metal protection cover.
10. Reconnect the BMS communication cable connector.
11. Verify that all of the alarms have cleared on the display.
12. Screw back the metal protection cover and the front panel, then clip the center cover.
13. If the UPS was shut down during the battery replacement process see [5.1 Start-up and Normal Operation](#).

Replacing the EBM(s)

The EBM is heavy. Lifting the cabinet into a rack requires a minimum of two people.

To replace the EBM(s):

1. Unplug the EBM power cable and battery detection cable from the UPS. If additional EBM(s) are installed, unplug the EBM power cable and battery detection cable from each EBM.
2. Replace the EBM(s). See [7.5 Recycling The Used Equipment](#) for proper disposal.
A small amount of arcing may occur when connecting an EBM to the UPS. This is normal and will not harm personnel. Insert the EBM cable into the UPS battery connector quickly and firmly.
3. Plug the EBM cable(s) into the battery connector(s). Up to four EBMs may be connected to the UPS.
4. Verify that the EBM connections are tight and that adequate bend radius and strain relief exist for each cable.
5. Connect the battery detection cable(s) to the connector of the UPS and of the EBM(s).
6. If the UPS was shut down during the battery replacement process see .

7.4 Battery Settings Reset

After replacement of the internal UPS batteries and extended battery modules the "BMS auto setup" and "Reset battery life" setting will need to be reset in the "Control" menu of the display.







1. Press the  button on the main display.
2. Press the  button to display the "Control" option. Press .
3. Press the  to display the "BMS auto setup" or "Reset battery life" option of the control menu. Press the  button and use the  to select "Yes". Press the  button to reset.

Figure 16. BMS Auto Setup



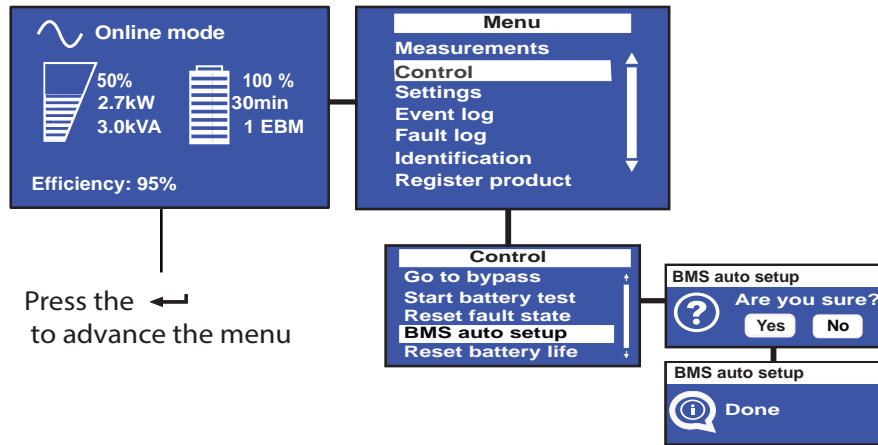
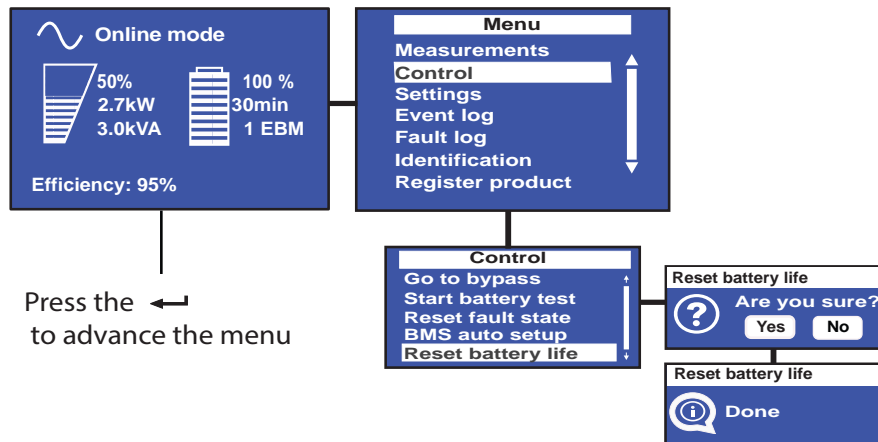

4. Reset the battery life counter in the “Reset Battery Life” option of the control menu.

Figure 17. Battery Life Reset



Return the UPS to Normal Operation

If the UPS internal batteries and external battery packs were replaced without powering down the UPS:

1. Check the UPS front panel display for active alarms or notices. Resolve any active alarms before continuing. See section [8.1 Typical Alarms and Faults](#) . If the  indicator is on, do not proceed until all alarms are clear.
2. Verify that the  indicator illuminates solid, indicating that the UPS is operating normally and any loads are powered and protected. The UPS should be in normal mode. [5.1 Start-up and Normal Operation](#) .

If the UPS internal batteries and external battery packs were replaced and the UPS was powered off:

1. Verify that the internal batteries are connected. See [Figure 15](#) .
2. If optional EBMs are installed, verify that the EBM are connected to the UPS.

7.5 Recycling The Used Equipment

Contact your local recycling or hazardous waste center for information on proper disposal of the used equipment.



RISK OF ELECTRIC SHOCK - Observe the warning associated with the risk of electric shock symbol.



This symbol indicates that you should not discard the UPS or the UPS batteries in the trash. This product contains sealed, Lithium-Ion batteries and must be disposed of properly. For more information, contact your local recycling/reuse or hazardous waste center.



This symbol indicates that you should not discard waste electrical or electronic equipment (WEEE) in the trash. For proper disposal, contact your local recycling/reuse or hazardous waste center.

Recycling The Used Equipment

Chapter 8 Troubleshooting

8.1 Typical Alarms and Faults

The Eaton 9PX are designed for durable, automatic operation and also alert you whenever potential operating problems may occur. Usually the alarms shown by the control panel do not mean that the output power is affected. Instead, they are preventive alarms intended to alert the user.

- Events are silent status information that are recorded into the Event log. Example = "AC freq in range".
- Alarms are recorded into the Event log and displayed on the LCD status screen with the logo blinking. Some alarms may be announced by a beep every 3 seconds. Example = "Battery low".
- Faults are announced by a continuous beep and red LED, recorded into the Fault log and displayed on the LCD with a specific message box. Example = Out. short circuit.





Use the following troubleshooting chart to determine the UPS alarm condition.

Checking the Alarms and Faults





To check the Event log or Fault log :

1. Press any button on the front panel display to activate the menu options.
2. Press the button to select Event log or Fault log.
3. Scroll through the listed events or faults.

The following table describes typical conditions.

Conditions	Possible cause	Action
Battery mode  LED is On. 1 beep every 10 seconds	A utility failure has occurred and the UPS is in battery mode.	The UPS is powering the equipment with battery power. Prepare your equipment for shutdown.
Battery mode  LED is On. 1 beep every 3 seconds	The UPS is in Battery mode and the battery is running low.	This warning is approximate, and the actual time to shutdown may vary significantly. Depending on the UPS load and number of Extended Battery Modules (EBMs), the "Battery Low" warning may occur before the batteries reach 20% capacity.
No battery  LED is On Beep continuous	The batteries are disconnected.	Verify that all batteries are properly connected. To clear a battery disconnected alarm a battery test must be initiated. See 2.7 User Settings . If the condition persists, contact your service representative.
Battery fault  LED is On Beep continuous	The battery test is failed due to bad or disconnected batteries.	Verify that all batteries are properly connected. If the condition persists, contact your service representative. To clear a battery disconnected alarm a battery test must be initiated. See 2.7 User Settings . If the condition persists, contact your service representative.

Silencing the Alarm

Conditions	Possible cause	Action
The UPS does not provide the expected backup time.	The batteries need charging or service.	Apply utility power for 48 hours to charge the batteries. If the condition persists, contact your service representative.
Bypass mode  LED is on.	An overload or a fault has occurred, or a command has been received and the UPS is in Bypass	Equipment is powered but not protected by the UPS. Check for one of the following alarms: overtemperature, overload or UPS LED is on. failure.
Power Overload  LED is on.	Power requirements exceed the UPS capacity (greater than 100% of nominal; see "User Settings" on page 8 for specific output overload ranges).	Remove some of the equipment from the UPS. The UPS continues to operate, but may switch to Bypass mode or shut down if the load increases. The alarm resets when the condition becomes inactive.
UPS Overtemperature  LED is on. 1 beep every 3 seconds	The UPS internal temperature is too high or a fan has failed. At the warning level, the UPS generates the alarm but remains in the current operating state. If the temperature rises another 10°C, the UPS transfers to Bypass mode or shuts down if Bypass is unusable.	If the UPS transferred to Bypass mode, the UPS will return to normal operation when the temperature drops 5°C below the warning level. If the condition persists, shut down the UPS. Clear vents and remove any heat sources. Allow the UPS to cool. Ensure the airflow around the UPS is not restricted. Restart the UPS. If the condition continues to persist, contact your service representative.
The UPS does not start	The input source is not connected correctly.	Check the input connections.
	The Remote Power Off (RPO) switch is active or the RPO connector is missing.	If the UPS Status menu displays the "Remote Power Off" notice, inactivate the RPO input.
Input bad wiring / Output bad wiring  LED is on. Beep is continuous.	Input/Output cables are not connected to the correct terminal blocks.	Connect correctly the Input/Output cables.
MBP Disconnected	The HotSwap MBP is no more connected to the UPS.	If the HotSwap MBP is connected to the UPS, check that the detection connector is correctly plugged.

8.2 Silencing the Alarm

Press the ESC (Escape) button on the front panel display to silence the alarm. Check the alarm condition and perform the applicable action to resolve the condition. If the alarm status changes, the alarm beeps again, overriding the previous alarm silencing.

8.3 Service and Support

If you have any questions or problems with the UPS, call your **Local Distributor** or your local service representative and ask for a UPS technical representative. Please have the following information ready when you call for service:

- Model number
- Serial number
- Firmware version number
- Date of failure or problem
- Symptoms of failure or problem
- Customer return address and contact information

If repair is required, you will be given a Returned Material Authorization (RMA) number. This number must appear on the outside of the package and on the Bill Of Lading (if applicable). Use the original packaging or request packaging from the Help Desk or distributor. Units damaged in shipment as a result of improper packaging are not covered under warranty. A replacement or repair unit will be shipped, freight prepaid for all warrantied units.



IMPORTANT

For critical applications, immediate replacement may be available. Call the Help Desk for the dealer or distributor nearest you.

8.4 Compliance Contact

- **€** Eaton I.F. SAS - 110 Rue Blaise Pascal - 38330 Montbonnot St Martin – France.
- **UK**
CA Eaton Electrical Ltd., P.O. Box 554, Abbey Park, Southampton Road, Titchfield, PO14 4QA, United Kingdom.

Chapter 9 Specifications

9.1 Model Specifications

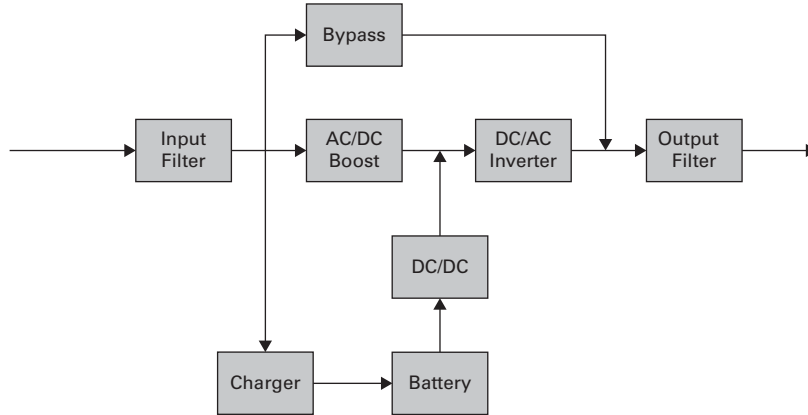

Table 7. Power Module List

Model	Power ratings
9PX6K-L	5200VA / 4600W at 200V Output
	5400VA / 4800W at 208V Output
	5700VA / 5100W at 220V Output
	6000VA / 5300W at 230V Output
	6000VA / 5400W at 240V Output

Table 8. Extended Battery Module List

Model	Configuration	Battery Voltage	For Power Module
9PXEBM192RT-L	Rack / Tower	192Vdc	6000VA

Table 9. Weights and Dimensions

Description	Weights (lb/kg)	Dimensions (inch/mm) D X W X H
9PX6K-L	81.4 / 36.9	27.0 x 17.3 x 5.1 / 685 x 440 x 130
9PXEBM192RT-L	78.9 / 35.8	25.4 x 17.2 x 3.4 / 645 x 438 x 85.3

Table 10. Electrical Input

Model	Default Input (Voltage/Max Current)	Input Nominal Voltages	Input Voltage Window at Rated Load
9PX6K-L	208V / 24.8A	200V, 208V, 220V, 230V, 240V	176-276V
Nominal Frequency		50/60Hz auto-sensing	

Table 10. Electrical Input (Continued)

Model	Default Input (Voltage/Max Current)	Input Nominal Voltages	Input Voltage Window at Rated Load
	Frequency Range	50Hz : 40-60Hz before transfer to battery 60Hz : 50-70Hz before transfer to battery	
	Bypass Voltage Range	-20% / +15% of nominal value (default)	
	Noise Filtering	MOV for normal and common mode noise	

Table 11. Electrical Input Connections

Model	Input Connection
9PX6K-L	L6-30P cord or Hardwired

Table 12. Electrical Output

All Models	Normal Mode	Battery Mode
Voltage Regulation	±1%	±1%
Efficiency	> 98% (High Efficiency mode) >93%	> 91%
Frequency Regulation	Sync with line ±5% of nominal line frequency (outside this range: ±0.5% of auto-selected nominal frequency)	±0.5% of auto-selected nominal frequency
Nominal Output	200*/208*/220*/230*/240V (voltage configurable) 6000VA* 4500/5400W*	
Frequency	50 or 60 Hz, autosensing or configurable as a frequency converter	
Output Overload	100-102% : no alarm 102-110% : load transfers to Bypass mode after 2 minutes 110-125% : load transfers to Bypass mode after 1 minute 125-150% : load transfers to Bypass mode after 10s > 150% : load transfers to Bypass mode after 500ms	
Output Overload (Bypass Mode)	100-125% : no alarm 125-150% : UPS shuts down after 1 minute > 150% : UPS shuts down after 1s	
Voltage Waveform	Sinewave	
Harmonic Distortion	< 2% THDV on linear load < 5% THDV on non-linear load	
Transfer Time	Online Mode: 0ms (no break) High Efficiency mode: 10ms maximum (due to loss of utility)	
Power Factor	Up to 0.9	
Load Crest Ratio	Up to 3:1	

Table 12. Electrical Output (Continued)

All Models	Normal Mode	Battery Mode
Output short-circuit current	Max RMS & delay time: 56.5A/150ms; The max peak value: 92A	
* 200/208/220/230V are derated at 4600/4800/5100/5300.		

Table 13. Electrical Output Connections

Model	Output Connection	Output Cable
9PX6K-L	Hardwired (2) L6-30R (2) L6-20R	No

Table 14. Environmental and Safety

Certifications	EN/IEC 62040-1 EN/IEC 62040-2 EN/IEC 62040-3 UL1778 5th edition CSA 22.2
EMC (Emissions)*	CISPR32 (EN55032) Class A AS/NZS CISPR32 Class A IEC 61000 -3-11 IEC 61000 -3-12 FCC part 15 Class A
EMC (Immunity)	IEC 61000-2-2 IEC 61000-4-2, Level 3 IEC 61000-4-3, Level 3 IEC 61000-4-4, Level 4 (also on signal ports) IEC 61000-4-5, Level 4, Criteria B IEC 61000-4-6, Level 3 IEC 61000-4-8, Level 4 IEC 61000-4-12
* for output cable < 10m.	
Agency Markings	CE cULus ; UKCA; RCM; Ukr; EAC; Cmim
Operating Temperatures	0 to 40°C (32 to 104°F) in Online mode, with linear derating for altitude Note: thermal protection switches load to Bypass in case of overheating.
Storage Temperatures	0 to 40°C (32 to 104°F) with batteries -15 to 60°C (5 to 140°F) without batteries
Transit Temperature	-25 to 55°C (-13 to 130°F)
Relative Humidity	0 to 95% no condensing
Operating Altitude	Up to 3,000 meters (9,843 ft) above sea level with 10% derating per 1000m

Table 14. Environmental and Safety (Continued)

Transit Altitude	Up to 10,000 meters (32,808 ft) above sea level
Audible Noise	< 45 dBA at 1 meter typical
UPS enclosure IP rating: IP20	
Power system: TN/TT/IT	
Protective class: Class I	

Table 15. Battery

	Internal Batteries	EBM
Rack / Tower configuration	9PX6K-L: 192Vdc	9PXEBM192RT-L: 192Vdc
Type	Lithium Iron Phosphate (LFP) battery module Lithium-Ion float service life 8 years /25°C	
Monitoring	Integrated battery management system (BMS) for temperature regulation and life cycle monitoring.	
EBM Battery Cable Length	350 mm / 13.78 in	

Table 16. Communications Options

Communication Bay	(1) available independent communication bay for connectivity cards
Communication Ports	RS-232 (DB9): 1200-19200 bps USB: 19200 bps
Relay Output Contacts	(4) relay outputs (normally open or normally closed)
Remote On/Off	2 pins jumper (normally open)
Remote Power Off	3 pins jumper (normally open or normally closed)



DPD-9PX2206 02