

Eaton®Power Xpert®Gateway PXGX UPS Card

User's Guide



p/n: 164000972
Revision 1

Class A EMC Statements

FCC Part 15

- NOTE**  This equipment has been tested and found to comply with the limits for a Class A digital device, pursuant to part 15 of the FCC Rules. These limits are designed to provide reasonable protection against harmful interference when the equipment is operated in a commercial environment. This equipment generates, uses, and can radiate radio frequency energy and, if not installed and used in accordance with the instruction manual, may cause harmful interference to radio communications. Operation of this equipment in a residential area is likely to cause harmful interference in which case the user will be required to correct the interference at his own expense.
-

Requesting a Declaration of Conformity

Units that are labeled with a CE mark comply with the following harmonized standards and EU directives:

- Harmonized Standards: EN 62040-2:2006
EN 55022:2006 Class A, EN 55024:1998+A1:2001:A2:2003
- EU Directives: 2004/108/EC, Council Directive relating to electromagnetic compatibility

The EC Declaration of Conformity is available upon request for products with a CE mark. For copies of the EC Declaration of Conformity, contact:

Eaton Power Quality Oy
Koskelontie 13
FIN-02920 Espoo
Finland
Phone: +358-9-452 661
Fax: +358-9-452 665 68

Eaton reserves the right to change specifications without prior notice. Eaton, Power Xpert, and X-Slot are registered trademarks and PowerChain Management is a trademark of Eaton Corporation or its subsidiaries and affiliates. Excel, Internet Explorer, Microsoft, and Windows are registered trademarks of Microsoft Corporation in the United States and other countries. Freescale is a trademark of Freescale Semiconductor, Inc. Google Chrome is a trademark of Google Inc. IBM is a registered trademark of International Business Machines Corporation. Linux is a registered trademark of Linus Torvalds. Micrel is a registered trademark of Micrel, Inc. Modbus is a registered trademark of Schneider Automation. Mozilla and Firefox are registered trademarks of the Mozilla Foundation. NetWare is a registered trademark of Novell, Inc. OpenView is a trademark of Hewlett-Packard Company. Phillips is a registered trademark of Phillips Screw Company. All other trademarks are property of their respective companies. All other trademarks are property of their respective companies.

©Copyright 2020 Eaton, Raleigh, NC, USA. All rights reserved. No part of this document may be reproduced in any way without the express written approval of Eaton.

Table of Contents

1 Introduction	1
1.1 Eaton Power Xpert Architecture	1
2 Getting Started	3
2.1 Installation Checklist	3
2.2 Installing the Card	4
2.3 Connecting the Card to the Computer	5
2.4 Installing the USB Driver Software (Windows XP)	7
2.5 Installing the USB Driver Software (Windows 7)	11
2.6 IP Address Assignments	16
2.6.1 Verifying IP Address	16
2.6.2 Assigning an IP Address	18
2.7 IPv6 Address Assignments	19
2.8 Network Configuration	20
2.9 Important Security Information	22
3 Configuring the Card	23
3.1 Navigating the Card's Web Page	24
3.2 Identifying Monitored Equipment	26
3.3 View and Configure Tasks Essential to Initial Configuration	26
3.4 Changing the Passwords	27
3.5 Setting the Date and Time	27
3.6 Configuring SNMP Options	28
3.6.1 Community Strings and Trap Recipients	28
3.6.2 Changing SNMP Access	29
3.6.3 System Location and System Contact	29
3.6.4 Management from an SNMP NMS	30
3.7 Configuring Modbus TCP/IP Options	30
3.8 Configuring HTTP and HTTPS	31
3.9 Automatic Shutdown of UPS-Protected Computers	31
3.9.1 Configuring NetWatch Shutdowns for a UPS without Load Segments	31
3.9.2 Configuring NetWatch Shutdowns for UPS with Load Segments	32
3.9.3 Shutdown Clients	33
3.10 UPS Power Management	33
3.10.1 Testing the UPS Battery	33
3.10.2 Testing the UPS System	34
3.10.3 Turning the UPS Load Segments On and Off	34
3.10.4 Scheduling a UPS Shutdown and Restart	34
3.11 Configuring E-Mail Notification	35
3.11.1 General E-Mail	35
3.11.2 Collective E-Mail	36

Table of Contents

3.12 Configuring EMP Settings	37
3.13 Saving and Restoring Configuration Settings	38
3.13.1 Creating a Backup	38
3.13.2 Restoring a Backup	38
4 Operation and Maintenance	41
4.1 PXGX UPS Card Panel Details	41
4.2 Indicator Descriptions	41
4.3 DIP Switch Description	42
4.4 Open Alarms	42
4.5 Generating Log Files	44
4.5.1 Data Log	44
4.5.2 Interval Log	44
4.5.3 Event Log	45
4.5.4 System Log	45
4.5.5 Erasing a Log	45
4.6 Upgrading Firmware	45
5 Root Certificate Authority Installation	47
5.1 Installing Root CA with Windows Internet Explorer 7 and Internet Explorer 8	47
5.2 Installing Root CA with Mozilla Firefox	52
5.3 Installing Root CA with Google Chrome	53
6 MIB Files	61
6.1 Selecting a UPS MIB File	61
6.2 Powerware UPS MIB	62
6.3 RFC 1628 UPS MIB	62
6.4 Eaton EMP MIB	63
6.5 Eaton Alarms+Traps MIB	63
6.6 Eaton OID Assignments	63
6.7 Entity MIB Files	63
6.8 Selecting the UPS Trap Type	63
7 Modbus Registers	65
7.1 Obtaining the Modbus Register Map	65
7.2 Returning Error Codes	65
7.3 Modbus Register Addressing	65
7.3.1 Modbus Function Codes	66
7.3.2 Data Formats	66
7.3.3 Data Addressing	66
7.4 UPS Unit ID Numbers	67
7.5 UPS Registers and Alarms	67
7.5.1 UPS Registers (FC 04)	67

7.5.2 UPS Alarms (FC 02)	68
7.6 EMP (FC 04)	69
7.7 Time or Date (FC 04)	70
8 Specifications	71
9 Service and Support	73
9.1 Two-Year Limited Warranty (US and Canada)	73

Table of Contents

Chapter 1 Introduction

The Eaton® Power Xpert® Gateway Card provides Web-enabled, real-time monitoring of Eaton uninterruptible power systems (UPSs) through standard Web pages, Power Xpert software, or third-party software. An integral part of the Eaton Power Xpert Architecture®, which provides end-to-end PowerChain Management™ solutions, the PXGX UPS card provides a central point to connect UPSs to the Ethernet network.

Network managers can view critical downstream device information, such as status, power, energy, and power quality data with an easy-to-use interface.

The PXGX UPS card has the following features:

- Web-enabled UPSs – view data from any location with a Web browser
- Real-time power monitoring – view critical device data and make informed network management decisions
- Integrated communications with Eaton’s Power Xpert software – monitor power devices in real time through Power Xpert software
- Simple Network Management Protocol (SNMP) support – integrate and manage your UPS with third party network management software
- Power quality data using Modbus® Transmission Control Protocol (TCP) – use this open communication protocol to communicate with standard building management systems
- Easy installation – install the PXGX UPS card while the UPS is online, maintaining the highest system availability
- Field upgradable – use the Web interface to easily upgrade the card's firmware in the field.

1.1 Eaton Power Xpert Architecture

Eaton Power Xpert Architecture provides the framework to unify the entire power system. It connects power systems with communication and management systems to provide a holistic approach to the entire power system. This strategic system-level focus is integral to PowerChain Management solutions. It provides increased reliability, cost efficiencies, enhanced safety and risk mitigation, and allows for the more effective use of capital. Eaton Power Xpert Architecture is comprised of both software and hardware components including meters, gateways, time servers, and connectivity devices.

Chapter 2 Getting Started



NOTE

If you have completed all sections in the Power Xpert Gateway PXGX UPS Card Quick Start Instructions, proceed to .

This section explains:

- Checklist items needed for installation
- Installing the card
- Connecting the card to the computer
- Installing the USB Driver Software (Windows XP and Windows 7)
- Verifying or assigning the IP address
- Configuring the network settings

2.1 Installation Checklist

1. Verify that the following items are available:
 - Power Xpert Gateway Minislot (PXGS) UPS Card package contents (card, cable, Quick Start Instructions)
 - Phillips® screwdriver
 - Available USB port on a computer running Microsoft® Windows®
 - Web browser (Microsoft Internet Explorer® version 8.0 and higher, Mozilla® Firefox®, or Google Chrome™ are recommended)
2. Set your computer screen resolution to 1280 by 1024 pixels or better for optimum viewing.
3. If you are going to use Dynamic Host Configuration Protocol (DHCP), provide your local network administrator with the card's MAC address. The MAC address is located on either the shipping box label or the label on this card.
 - MAC Address _____
4. If you are not going to use DHCP to provide any of the settings listed below, contact your local network administrator for the settings. Select DHCP or enter the values for manual configuration in the table below:

Item	DHCP*	Manual Configuration
IPv4	<input type="checkbox"/>	Card IP Address: _____ Netmask: _____ Gateway: _____
DNS – Name Servers	<input type="checkbox"/>	Name Server #1: _____ Name Server #2: _____ Name Server #3: _____
DNS – Domain	<input type="checkbox"/>	Domain: _____

* The network administrator normally sets up the DHCP server to provide a static IP address each time the card makes a DHCP request.

5. If you need e-mail functionality, obtain the SMTP mail server's IP address or host name. If using the SMTP host name, verify that you also have the Name Server IP address (see [Step 4](#)).

SMTP (mail server) IP Address

or Host Name _____

2.2 Installing the Card

The hot-swappable PXGX UPS Card can be installed without turning off the UPS or disconnecting the load.

To install the PXGX UPS Card:

1. Verify that all six DIP switches on the card are in the OFF position (see [Figure 1](#)).

Figure 1. Verify DIP Switches are OFF

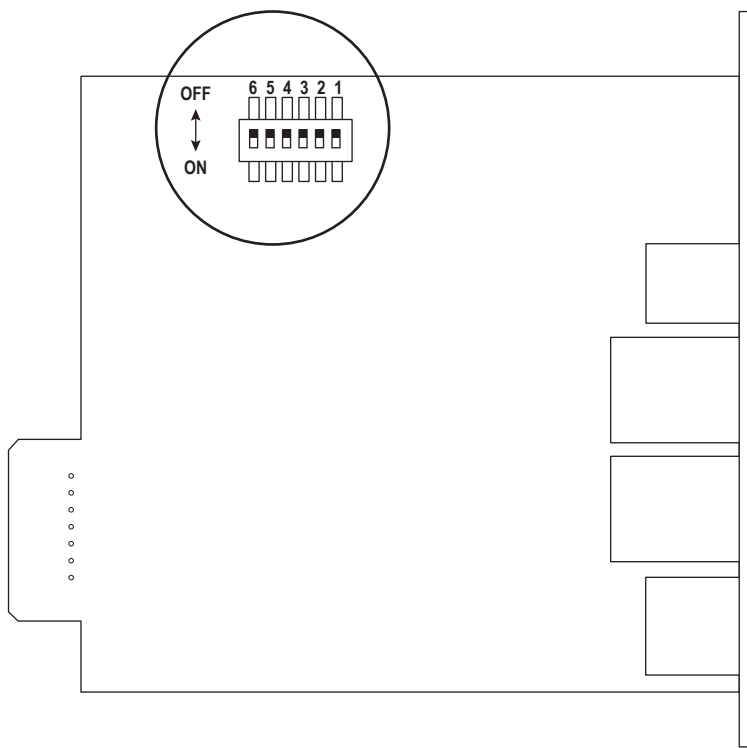

2. Remove the X-Slot® cover from the UPS. Retain the screws.



NOTE

If there is another card already installed with an attached communication cable, disconnect the cable and then remove the card.

3. If not already done, record the MAC address for future reference (see of the "Installation Checklist").
4. To prevent electrostatic discharge (ESD), place one hand on a metal surface such as the UPS panel.
5. Slide the card into the open slot and secure with the screws removed in Step 2 (see [Figure 2](#) and [Figure 3](#)).

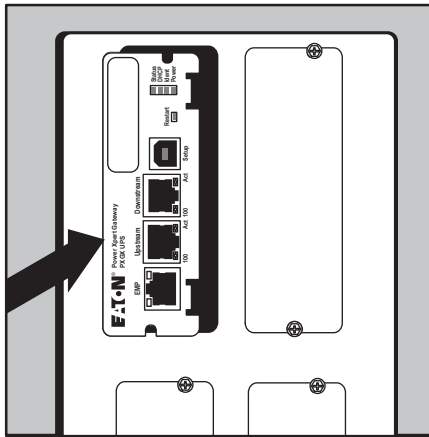
Figure 2. Install the PXGX UPS Card

6. Connect an active Ethernet cable (not supplied) to the Upstream Ethernet connector on the PXGX UPS Card (see [Figure 3](#)).
7. If you are connecting to another PXGX UPS Card or other Ethernet device, connect an Ethernet cable (not supplied) to the Downstream Ethernet connector on the PXGX UPS Card.

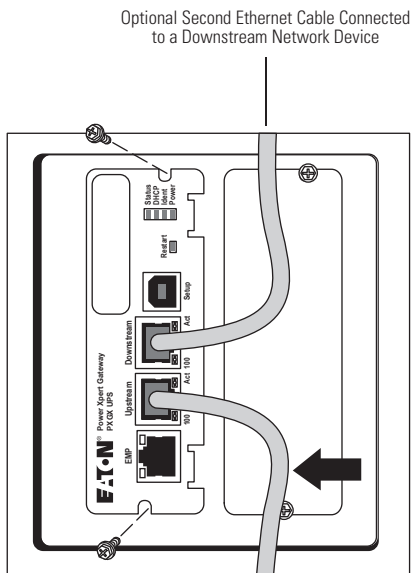
Figure 3. Secure the Card and Install the Ethernet Cable

2.3 Connecting the Card to the Computer

To connect the card to the computer and start the configuration:

1. Go to www.eaton.com/pxgx and download the powerxpert.inf file. Note the location of the file.
2. Plug the supplied USB cable into the Setup port on the card (see [Figure 4](#)).

Figure 4. Install the USB Cable

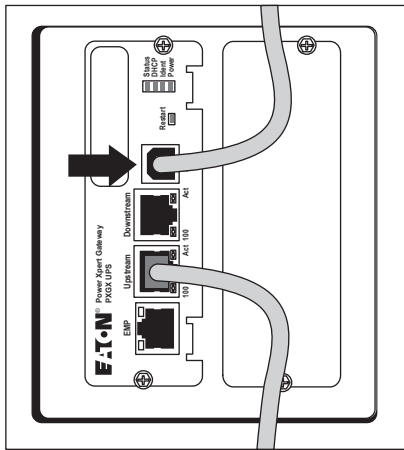

3. Plug the other end of the USB cable into the USB port on the computer. The Windows operating system detects new hardware.
4. The steps for installing the USB driver software are determined by the type of operating system running on your computer:
 - For Windows XP, go to Step 5.
 - For Windows 7, go to Step 6.
5. The Found New Hardware Wizard – Welcome window opens (see [Figure 5](#)). Continue to [2.4 Installing the USB Driver Software \(Windows XP\)](#) “Installing the USB Driver Software (Windows XP)”.

Figure 5. Found New Hardware Wizard – Welcome Window



6. If a message displays indicating that the device driver software was not successfully installed, click **Ignore**.
7. Continue to [2.5 Installing the USB Driver Software \(Windows 7\)](#).

2.4 Installing the USB Driver Software (Windows XP)

To install the USB driver software on a computer running Windows XP:

1. Select **No, not this time** and click **Next**. The Found New Hardware Wizard – Install Software window opens (see [Figure 6](#)).

Figure 6. Found New Hardware Wizard – Install Software Window

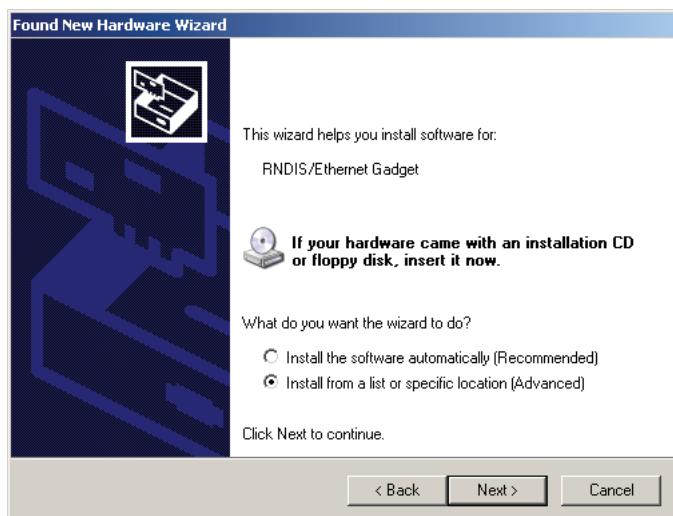

2. Select **Install from a list or specific location (Advanced)** and click **Next**. The Found New Hardware Wizard – Installation Options window opens (see [Figure 7](#)).

Figure 7. Found New Hardware Wizard – Installation Options Window

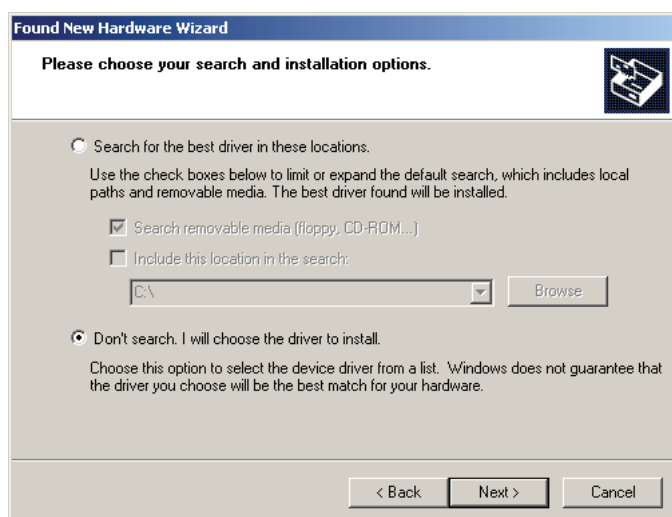

3. Select **Don't search. I will choose the driver to install.** and click **Next**. The Found New Hardware Wizard – Hardware Type window opens (see [Figure 8](#)).

Figure 8. Found New Hardware Wizard – Hardware Type Window

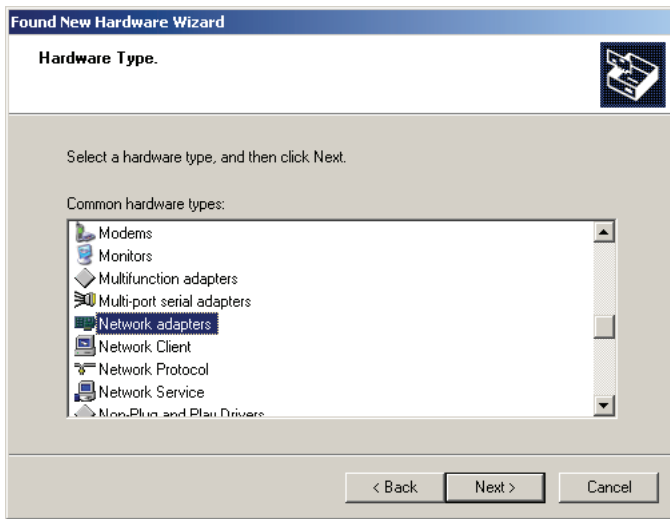

4. Select **Network adapters** and click **Next**. The Found New Hardware Wizard – Select Network Adapter window opens (see [Figure 9](#)).

Figure 9. Found New Hardware Wizard – Select Network Adapter Window

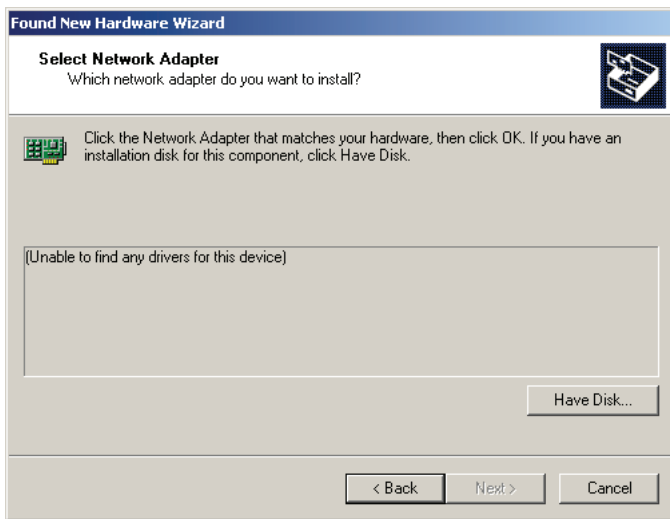

5. Select **Have Disk**. The Install From Disk window opens (see [Figure 10](#)).



NOTE

Disregard the instruction to insert the manufacturer’s installation disk in the window. The driver is installed from the “powerxpert.inf” file downloaded in [2.3 Connecting the Card to the Computer](#) “Connecting the Card to the Computer”.

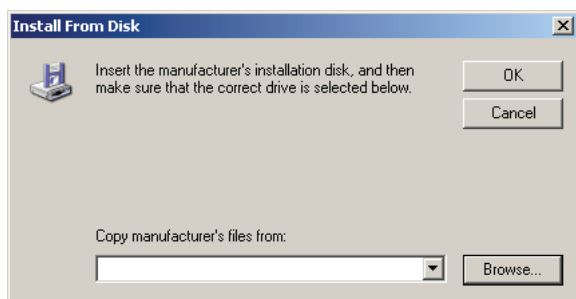
Figure 10. Install From Disk Window

6. Click **Browse**. The Locate File window opens.
7. Go to the folder containing the powerxpert.inf file that you downloaded in Step 1 of “Connecting the Card to the Computer” on page 5.
8. Select **powerxpert.inf** and click **Open**. The folder containing the powerxpert.inf file displays in the **Copy manufacturer’s file from** box (see [Figure 11](#)).

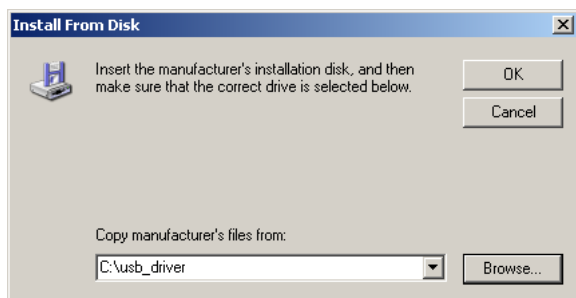
Figure 11. Install From Disk Window

9. Click **OK**. The Network Adapter displays in The Found New Hardware Wizard – Select Network Adapter window (see [Figure 12](#)).

Figure 12. Found New Hardware Wizard – Select Network Adapter Window

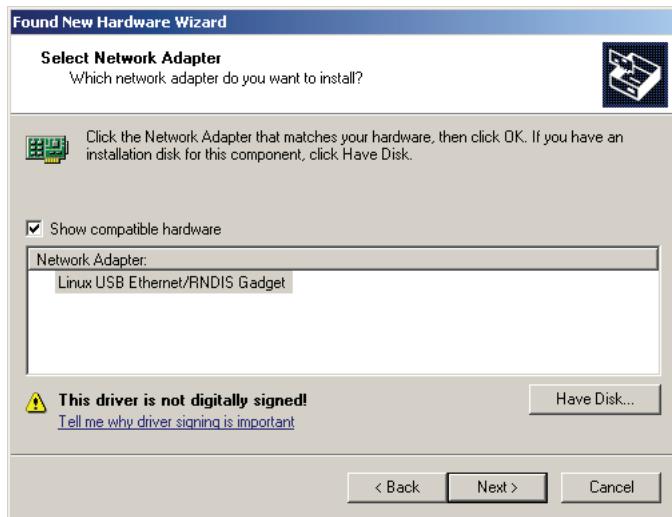

10. Select **Linux USB Ethernet/RNDIS Gadget** and click **Next**.
11. If the caution message shown in [Figure 13](#) displays, click **Continue Anyway**.

Figure 13. Caution Message

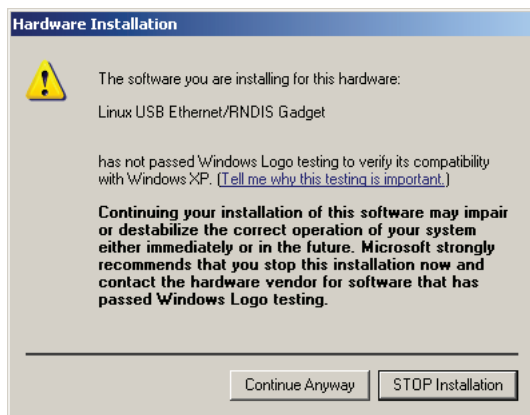

12. The wizard installs the software for the USB driver. The Found New Hardware Wizard – Completing the Found New Hardware Wizard window opens (see [Figure 14](#)).

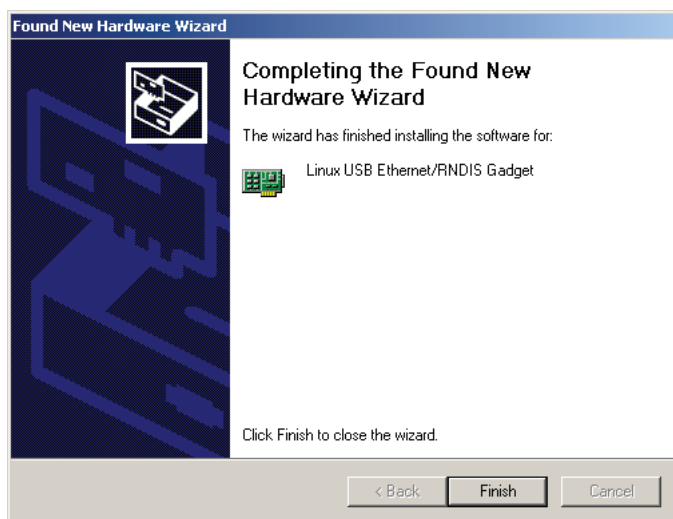
Figure 14. Found New Hardware Wizard – Completing the Found New Hardware Wizard Window

13. Click **Finish** to close the wizard.
14. Open the Network Connections window to verify that the installation was successful (see [Figure 15](#)). If “Linux USB Ethernet/RNDIS Gadget” is listed in the Device Name column, the USB driver has been successfully installed.

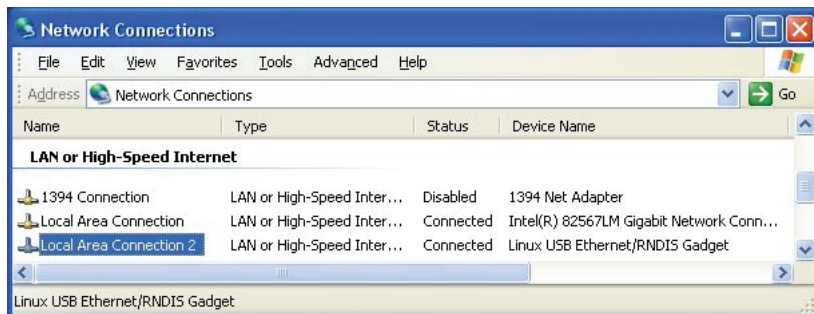
Figure 15. Network Connections Window

15. To verify the IP address assigned through DHCP, continue to [2.6.1 Verifying IP Address](#) “Verifying IP Addresses”
16. To manually enter a fixed IP address for the card’s network connection, continue to [2.6.2 Assigning an IP Address](#) “Assigning an IP Address”.

**NOTE**

By default, the PXGX UPS Card requests an IP address through DHCP when the card is connected to a network.

2.5 Installing the USB Driver Software (Windows 7)

To install the USB driver software on a computer running Windows 7:

1. Open the Control Panel and select **Hardware and Sound > Devices and Printers** (see [Figure 16](#)).

Figure 16. Control Panel Window – Hardware and Sound

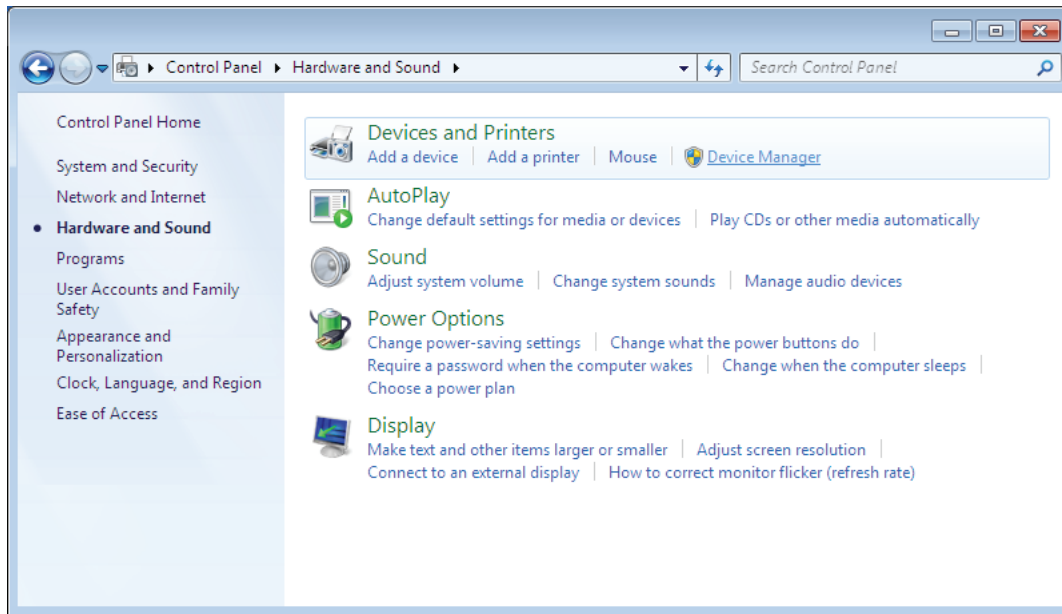

2. Select **Device Manager** to open the Device Manager window.
3. Expand **Other devices** and select **RNDIS/Ethernet Gadget** (see [Figure 17](#)).
4. Right-click and select **Update Driver Software**.

Figure 17. Device Manager Window

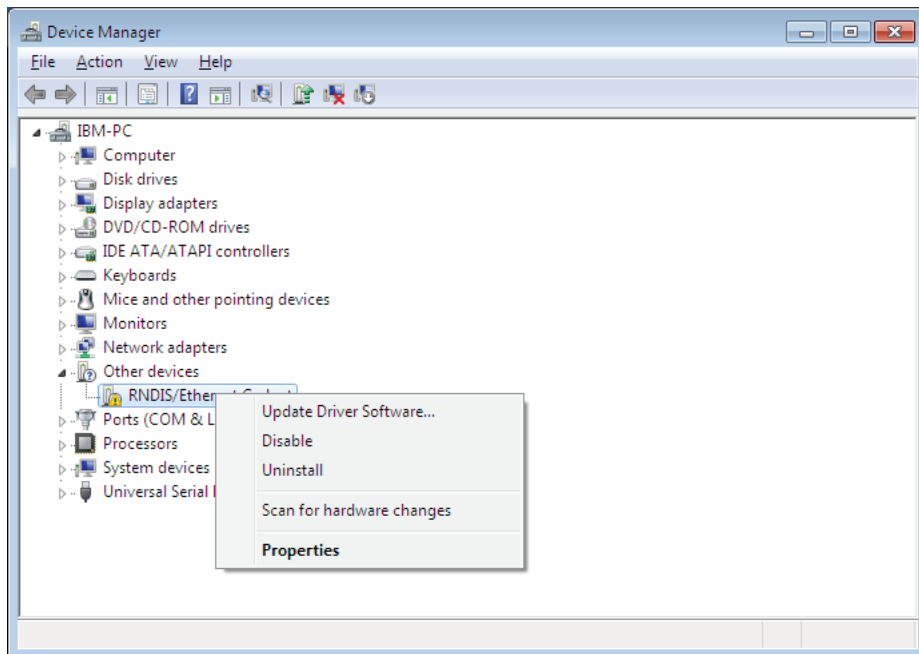

5. Select **Browse my computer for driver software** (see [Figure 18](#)).

Figure 18. Update Driver Software Window – Search Method

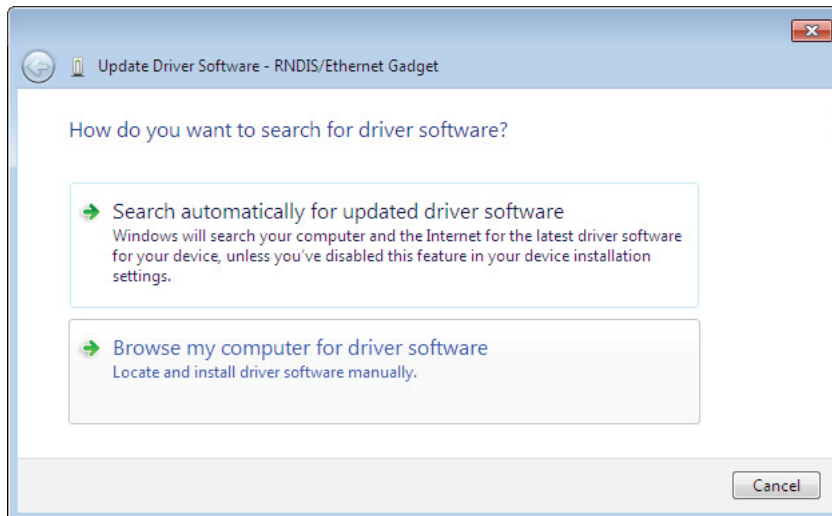

6. Click **Browse**. The Locate File window opens.
7. Locate and select the folder containing the powerxpert.inf file that you downloaded in Step 1 of [2.3 Connecting the Card to the Computer](#) "Connecting the Card to the Computer".
8. Click **Open**. The folder displays in the **Search for driver software in this location** box (see [Figure 19](#)).

Figure 19. Update Driver Software Window – Browse for Driver Software

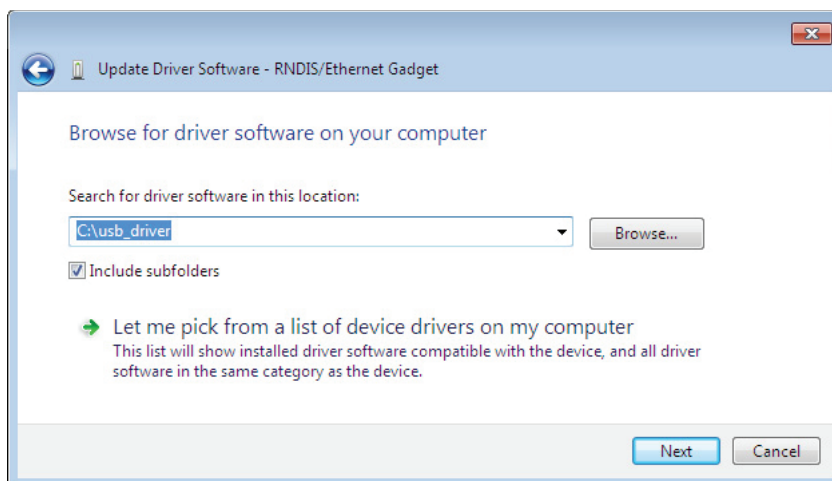

9. Click **Next**.
10. If the message "Windows can't verify the publisher of this driver software" displays, select **Install this driver software anyway** (see [Figure 20](#)).

Figure 20. Windows Security Message

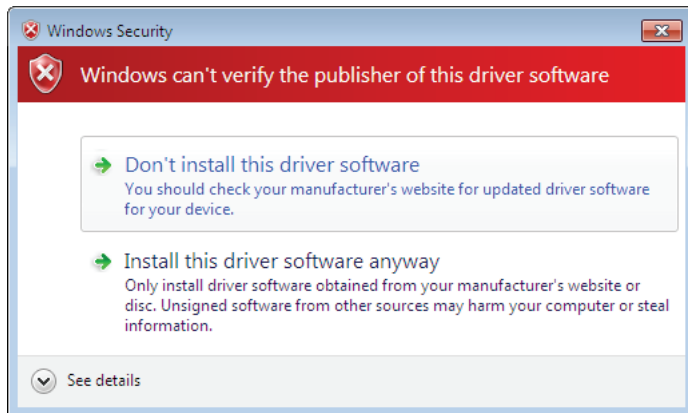

11. The message "Windows has successfully updated your driver software" displays (see [Figure 21](#)).

Figure 21. Update Driver Software Window – Update Successful

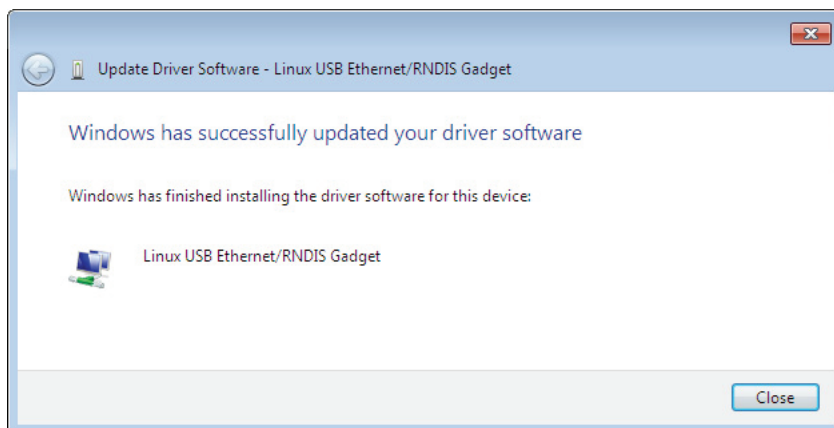

12. To verify the device is installed:
- Go to **Control Panel > Hardware and Sound > Devices and Printers > Device Manager**.
 - Expand **Network adapters**.
 - Verify that **Linux USB Ethernet/RNDIS Gadget** is listed under Network adapters (see [Figure 22](#)).

Figure 22. Device Manager Window – Verify Device Installation

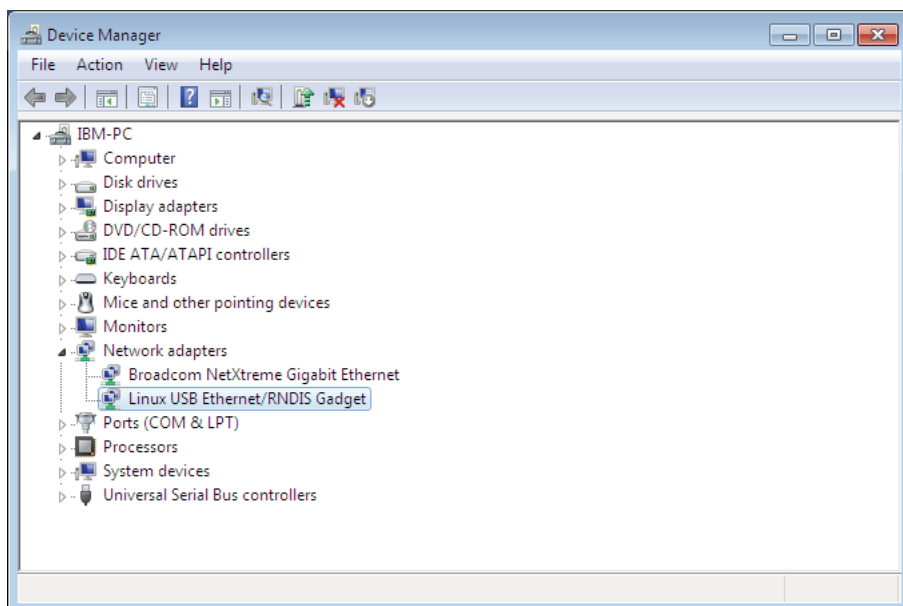

13. From the **Start** menu, go to **All Programs > Accessories > Command Prompt** to open a Command Prompt window.
14. Enter **ipconfig /all**.

The adapter IP addressing information displays. Verify that the assigned IPv4 address is in the following range (See [Figure 23](#)):

- 169.254.0.x range for firmware 2.6.0.0 or later
- 192.168.200.x range for earlier firmware versions where “x” is typically “1.”

The USB driver software installation is complete.

Figure 23. Command Prompt Window – Adapter IP Address Information

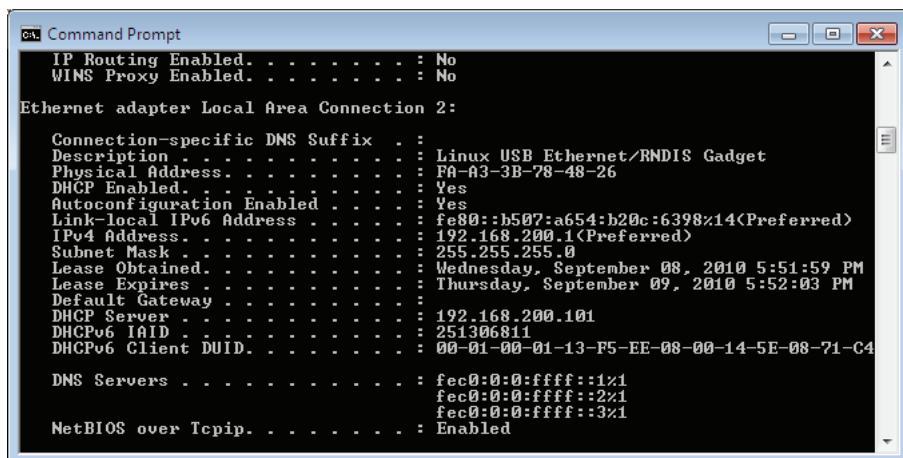

2.6 IP Address Assignments

Many IT managers prefer the convenience of DHCP for managing the IP addresses of networked devices. With DHCP, IT managers can easily reassign IP addresses as the network structure changes. In some cases, DHCP may not be available, or fixed IP addresses may be preferred for the PXGX UPS Card (for example, if some other networked device needs to reach the card at a fixed address).

To verify the IP addresses assigned through DHCP, continue to [2.6.1 Verifying IP Address](#) "Verifying IP Addresses." To manually enter fixed IP addresses for the card's network connection, continue to [2.6.2 Assigning an IP Address](#) "Assigning an IP Address" on page 17.



NOTE

By default, the PXGX UPS Card requests an IP address through DHCP when connected to a network.

2.6.1 Verifying IP Address

To verify the IP address assignment:

1. Connect to the card over the USB cable:
 - a. Open your Web browser.
 - b. Enter: **http://169.254.0.101** for firmware 2.6.0.0 or later, **http://192.168.200.101** for earlier firmware versions.
You are prompted to log on.
2. Log on as administrator.
 - For firmware 2.6.0.5 and higher the username is "**admin**" and the default password is the card's MAC address (case sensitive with no colons).
For example: Card's MAC address: 00:E0:D8:FF:C0:C4
 - Administrator name: admin
 - Password: 00E0D8FFC0C4
 - For firmware versions older than 2.6.0.5 the default username and password is "**admin**".
3. Select **Network** from the Configuration menu. The Network page displays (see [Figure 24](#)).

Figure 24. PXGX UPS Card Network Page

The screenshot displays the Eaton Power Xpert Gateway UPS Card Network Configuration page. The browser window title is "Eaton Power Xpert Gateway UPS Card - Windows Internet Explorer" and the address bar shows "http://192.168.200.101". The page header includes the Eaton logo, "Power Xpert GATEWAY", and the date/time: "11/03/2010 13:45:30 UTC" and "11/03/2010 09:45:30 EDT".

The left sidebar contains a "Menu" with options: Device Data, Open Alarms, Logs, Configuration (7), Essential Configuration Tasks, Access Control, Network, Date/Time, Email, Modbus TCP, SNMP, UPS, Save and Restore, Firmware, Log on as 'user', and Documentation.

The main content area is titled "Network" and contains the following sections:

- System Information:**
 - System location:
 - System contact:
- Network:**
 - MAC: 00:20:85:FC:07:14
 - IPv4:**
 - Automatic Configuration: DHCP Enabled: DHCP Lease Obtained: No
 - Manual Configuration:**
 - IP Address:
 - Netmask:
 - Gateway:
 - IPv6:**
 - Gateway:
 - Automatic Address: 2002:c0a8:101:0:220:85ff:fe7c:714/64
 - Link-Local Address: fe80::220:85ff:fe7c:714/64
 - Static Address:
- Name Service Settings:**
 - Use DHCP (when enabled) to get name servers:
 - Name Server #1:
 - Name Server #2:
 - Name Server #3:
 - Use DHCP (when enabled) to get domain name:
 - Domain:
 - Hostname:
- Actions:**
 - Ping Test:
 - HTTP Get Test:
 - Reboot Network card:

At the bottom of the configuration area are "Apply" and "Discard" buttons. The footer of the page includes "3rd Party Licensing" and "Copyright 2010 Eaton Corporation. All Rights Reserved".

4. Verify that the network settings match those on the [2.1 Installation Checklist](#). If you are manually configuring the network settings, go to [2.6.2 Assigning an IP Address](#).
 5. Verify network communication:
 - a. Clear the DHCP Enabled check box. The text fields that were dimmed in the Manual Configuration section are now available.
 - b. Copy the IP address.
 - c. Open a second browser and paste the IP address in the Address bar and click Go. If the assigned IP address is working, you will be prompted to log on.
 - d. Log on as administrator.
 - For firmware 2.6.0.5 and higher the username is “admin” and the default password is the card's MAC address (case sensitive with no colons).
For example: Card's MAC address: 00:E0:D8:FF:C0:C4
 - Administrator name: admin
 - Password: 00E0D8FFC0C4
- The PXGX UPS Card Web page displays.

2.6.2 Assigning an IP Address

To manually enter a fixed IP address for the card:

1. Open your Web browser and enter: **http://169.254.0.101** for firmware 2.6.0.0 or later, **http://192.168.200.101** for earlier firmware versions. You are prompted to log on.
 2. Log on as administrator.
 - For firmware 2.6.0.5 and higher the username is “**admin**” and the default password is the card's MAC address (case sensitive with no colons).
For example: Card's MAC address: 00:E0:D8:FF:C0:C4
 - Administrator name: admin
 - Password: 00E0D8FFC0C4
 - For firmware versions older than 2.6.0.5 the default username and password is “**admin**”.
- The PXGX UPS Card Web page displays.
3. Select **Network** from the Configuration menu. The Network page displays (see [Figure 24](#)).
 4. Clear the **DHCP Enabled** check box to enable manual configuration.
 5. Enter the IP, Netmask, and Gateway addresses in the Manual Configuration section and click Apply.
 6. Click **OK** to confirm.
 7. If you will be using a host name, or host names, for controlling access to the card, type the server IP address in the Name Server field. Up to three IP addresses can be entered.
 8. Click **Apply**.
 9. Click **OK** to confirm.
 10. Verify network communication:
 - a. Copy the IP address you entered in Step 5.

- b. Open a second browser and paste the IP address in the Address bar and click **Go**. You are prompted to log on.
 - c. Log on as administrator.
 - For firmware 2.6.0.5 and higher the username is “**admin**” and the default password is the card's MAC address (case sensitive with no colons).
For example: Card's MAC address: 00:E0:D8:FF:C0:C4
 - Administrator name: admin
 - Password: 00E0D8FFC0C4
 - For firmware versions older than 2.6.0.5 the default username and password is “**admin**”.
- If the if the PXGX UPS Card Web page displays, the fixed IP Address is correct.

11. If you logged on as administrator and require additional options, continue to or .



NOTE You must be logged on as admin to configure the card.

To prevent unauthorized access after you are done configuring the card, close the browser or log off as admin. To log off as admin, select **Log on as 'user'** from the Configuration menu:

- For firmware 2.6.0.5 and higher the username is “**user**” and the default password is the card's MAC address (case sensitive with no colons).
For example: Card's MAC address: 00:E0:D8:FF:C0:C4
 - User name: user
 - Password: 00E0D8FFC0C4
 - For firmware versions older than 2.6.0.5 the default username and password is “**user**”.
- Logging on as user sets the security level to read-only.

2.7 IPv6 Address Assignments

There are four sets of IPv6 addresses that can be assigned to the card:

- **Gateway.** Manually assigned IPv6 Gateway address.
- **Link-Local Address.** The Link-Local Address is a permanent address assigned to the card.
- **Automatic Address.** This address only displays if the card is connected to a network router that supports stateless address auto-configuration.
- **Static Address.** Manually assigned fixed IPv6 address.



NOTE Only the Gateway and Static addresses are user-configurable. The Link-Local and Automatic addresses are automatically populated.



NOTE Dynamic Host Configuration Protocol for IPv6 (DHCPv6) is not supported.

To manually enter a fixed IP address for the card:

1. Open your Web browser and enter: **http://169.254.0.101** for firmware 2.6.0.0 or later, **http://192.168.200.101** for earlier firmware versions. You are prompted to log on.
2. Log on as administrator.

- For firmware 2.6.0.5 and higher the username is "**admin**" and the default password is the card's MAC address (case sensitive with no colons).
For example: Card's MAC address: 00:E0:D8:FF:C0:C4
 - Administrator name: admin
 - Password: 00E0D8FFC0C4
 - For firmware versions older than 2.6.0.5 the default username and password is "**admin**".
- The PXGX UPS Card Web page displays.
3. Select **Network** from the Configuration menu. The Network page displays (see [Figure 24](#)).
 4. Enter the Static and Gateway addresses in the IPv6 section.
 5. Click **Apply**.
 6. Click **OK** to confirm.

2.8 Network Configuration

If you know the card's IP address, you can configure the network settings from the card's Web page. To configure the network settings:

1. Open a Web browser, type the IP address of the card, and select **Go**.
 2. Log on as administrator.
 - For firmware 2.6.0.5 and higher the username is "**admin**" and the default password is the card's MAC address (case sensitive with no colons).
For example: Card's MAC address: 00:E0:D8:FF:C0:C4
 - Administrator name: admin
 - Password: 00E0D8FFC0C4
 - For firmware versions older than 2.6.0.5 the default username and password is "**admin**".
- The PXGX UPS Card's initial page displays (see [Figure 25](#)).

Figure 25. Initial Page – Device Overview and Summary

The screenshot shows the web interface for the Eaton Power Xpert Gateway UPS Card. The browser window title is "Eaton Power Xpert Gateway UPS Card - Microsoft Internet Explorer". The address bar contains the text "Enter the card's IP address here." circled in red. The interface includes a navigation menu on the left with options like "Device Data", "Open Alarms", "Logs", "Configuration", and "Documentation". The main content area is divided into "Overview" and "Summary" sections. The "Overview" section displays a network diagram and system status: System Status: On, Percent Full Load: 36 percent, Output Demand: 0.0195833 kilowatt-hours, Energy: 0.176262 kilowatt-hours, and Percent Battery Left: 95 percent. The "Summary" section provides identification details for the Power Xpert Gateway Card, including display name, hardware version, location, model name, part number, serial number, software version, vendor name, and contact information.

- Identification	
Display Name:	Power Xpert Gateway Card
Field Replaceable Unit:	Yes
Hardware Version:	Cpu: MPC8313ERDB Architecture: powerpc Board: pxgx-co
Location:	Raleigh Lab
Model Name:	PXGX UPS
Part Number:	103007974-5591
Serial Number:	00:20:85:FC:07:26
Software Version:	1.4.5-r39385-ups
Vendor Name:	Eaton Corporation
Who To Contact:	Ryan Borowitz
- Measure/Alarm	
A Restart is Pending:	false

3. Select **Network** from the Configuration menu to open the Network configuration page.
4. You can enable or disable DHCP control by selecting or clearing the check box. The default is **DHCP enabled**.
5. If you want the card to access other network servers (such as an SMTP server) by host name, type the server IP address in the **Name Server** field. Up to three IP addresses can be entered.
6. If you will be using Simple Network Management Protocol (SNMP), identify the physical location of the installed card in the **System location** field. This value also displays in the banner.
7. Enter the information to identify someone to contact with questions about this device in the **System contact** field. For example, you can type a person's name, phone number, department, e-mail address, or physical location.
8. You can also modify the card's IP address, the subnet mask, and the gateway address (**IP Address**, **Netmask**, and **Gateway** fields).
9. To test the card's network connection to other network servers, such as an SMTP server, you can ping (request acknowledgement from) the host. Enter the IP address or hostname in the **Ping test** field and then click **Test**.

10. Click **Apply** to save the settings or **Discard** to cancel the changes.
11. Continue to [Chapter 3 Configuring the Card](#) for additional configuration options.

2.9 Important Security Information

By default, the PXGX UPS Card is configured to prevent unauthorized SNMP and Modbus TCP access by computers that are not on the Trusted IPs/Hostnames list.

If you are using SNMP or Modbus TCP, see [3.6.2 Changing SNMP Access](#) to add specific IP addresses or host names of trusted computers.

Chapter 3 Configuring the Card

 **NOTE** If DHCP is disabled and you will be using host names for servers, such as the mail server, Network Time Protocol (NTP) server, SNMP hosts, Modbus TCP hosts, or trap recipients, “enter” the IP address of your network DNS Server (see [2.8 Network Configuration](#)).

 **NOTE** You must be logged on as admin to configure the card.

To prevent unauthorized access after you are done configuring the card, close the browser or log off as admin. To log off as admin, select **Log on as 'user'** from the Configuration menu.

To login as user:

- For firmware 2.6.0.5 and higher the username is “**user**” and the default password is the card's MAC address (case sensitive with no colons).
For example: Card's MAC address: 00:E0:D8:FF:C0:C4
 - User name: user
 - Password: 00E0D8FFC0C4
- For firmware versions older than 2.6.0.5 the default username and password is “**user**”.

Logging on as user sets the security level to read-only.

This section explains:

- Navigating the card's Web page
- Identifying monitored equipment
- Configuring essential tasks
- Changing the passwords
- Setting the date and time
- Configuring SNMP options and managing from an SNMP NMS
- Configuring Modbus TCP/IP options
- Configuring HTTP and HTTPS
- Configuring automatic shutdown of UPS-protected computers
- Managing UPS power
- Configuring e-mail notification
- Configuring the Environmental Monitoring Probe (EMP)
- Saving and restoring configuration settings

3.1 Navigating the Card's Web Page

Figure 26 shows an example of the overview page that displays when you log on to the card's interface.

Figure 26. Navigating the Card's Web Page



Areas and features of the card's Web page:

- **Banner.** The page banner displays the gateway time in UTC (Coordinated Universal Time). The local time and system location can be configured to also display in the banner.

If there is an active alarm in the hardware, a flashing alarm icon with an alarm message displays in the banner. Click the alarm message in the banner to display the Open Alarms page.

The highest level of an alarm active in the UPS displays as follows:

- Red for critical
- Yellow for caution
- Blue for acknowledged, but not closed (still alarming)

i NOTE An active alarm is different from an open alarm:

- **Alarms.** There are two different alarmed conditions. The two conditions are an active alarm and an open alarm:
 - **Active Alarm.** An alarm is active when an alarming condition exists in the UPS. Messages display on the UPS LCD panel and on the card interface banner when alarms go active and disappear when the alarming condition clears.
 - **Open Alarm.** When an alarm goes active, it is also considered open and remains open (even after the condition clears in the UPS hardware) until it is closed by an operator. Operators are required to close alarms to ensure they are seen. While the UPS LCD panel and the card interface banner display the alarms that are active in the UPS, other areas of the card interface, (such as the Open Alarms page, device data pages, and the alarm log), display any alarms that have not been closed by the operator. Since closing an alarm that is still active in the hardware quickly results in the generation of a new alarm, an operator has the option to mark an alarm as acknowledged to indicate it has been seen.
To close or acknowledge an open alarm, see [4.4 Open Alarms](#).
- **Menu Bar.** The menu bar contains links to additional pages for status information and configuration options. Menus are expandable and collapsible. The Device Data menu is expanded when you first log on. If an alarm is active, the Open Alarms menu category turns red and the number of open alarms displays in parentheses, so that alarms are never hidden even if the menu is collapsed. Use the menu bar to move through the card's Web pages.
- **Analog Gauges.** Analog gauges display on the Overview and Device Data pages next to metered items to show related critical device information, such as status, power, and energy levels at a glance. Examples of metered items are:
 - Percent full load
 - Percent battery left
 - Bypass, input, and output frequency
 - Battery time remaining
 - Power output
 - Remote humidity and temperature (if the optional EMP is connected to the card)

The bar is green for the normal operating range (white background) and gradually changes to yellow and then red as it moves to the caution range (light blue background) to critical (darker blue background).

Pause the pointer over the information icon to display numerical limits.

- **Overview.** The Overview displays a functional status diagram of the UPS (or UPSs in a parallel system). The animated yellow line shows the direction of the energy flow. To the right of the diagram, a list of the most relevant current readings displays. The List tab page displays a complete list of current readings.
- **Summary Tab.** The Summary tab page displays essential data most often used to determine the overall status of the device. Alarms display in red text. Pause the pointer over items for additional detail or help.
- **List Tab.** The List tab page displays an expanded list of configurable and measurable items and alarms. The categories on the List tab page are expandable and collapsible. Alarms display in red text. Pause the pointer over items for additional detail or help.

 **NOTE** The Output KW Hours displays on the Overview and also on the Device and List tabbed pages. Because the Output KW Hours is reset to zero when the card is restarted, Eaton recommends that this feature not be used for billing purposes. If you choose to use this value for billing purposes, record the Output KW Hours before restarting the card.

- **Atom Web Feed.** The card supports Atom Syndication Format (Atom) for Web feeds. The orange Atom icon is in the status bar. Click the Atom Feed icon to view new content or subscribe to the PXGX UPS Card feed data. Some browsers also display the Atom Feed icon in the address bar.

- **3rd Party Licensing link.** The 3rd Party Licensing link in the status bar directs you to a list of all licenses used with the PXGX UPS Card. Each listing links to the full license text.

3.2 Identifying Monitored Equipment

The Device Data menu lists the monitored equipment (card, UPS, load segments, and optional EMP). Each equipment page has a Summary tab and a List tab. The List tab page displays detailed information related to the equipment. You can choose the information you want to display and whether you want items organized by category with headings displayed, or all items in alphabetical order. You can modify some values, such as identification labels.

**NOTE**

The configurable values may also be available on other pages, such as the System Location field on the Network Configuration page. Changes made to these fields are updated everywhere they appear.

Configurable fields for the card are:

- Display Name
- Location
- Who to Contact

Configurable fields for the UPS are:

- Asset Identification Tag
- Display Name
- Attached Devices
- Battery Last Replaced Date
- Date Last Serviced
- Installation Date
- Low Runtime Alarm Setpoint (An alarm is sent indicating the time remaining before the battery is depleted. Increasing the time allows for additional time to shut down a system before the battery is depleted).

**NOTE**

See [3.9 Automatic Shutdown of UPS-Protected Computers](#) for information on power outage notification and configuring the shutdown process for registered NetWatch clients.

The configurable field for load segments is Display Name

Configurable fields for the EMP are:

- Asset Identification Tag
- Display Name

3.3 View and Configure Tasks Essential to Initial Configuration

The Essential Configuration Tasks page provides a summary of important tasks relating to the card's initial setup and configuration. If essential tasks have not been configured, the Configuration category on the menu bar displays in red along with the number of unconfigured essential tasks. Other unconfigured tasks display in blue on the Essential Configuration Tasks page.

To configure essential tasks:

1. Select **Essential Configuration Tasks** from the Configuration menu.

The Essential Configuration page displays. Unconfigured tasks have links to the associated configuration page. Configured tasks are identified as "Ok."

2. Click the link for the task you want to configure. The associated configuration page displays.
3. Complete the configuration and click **Apply**.

**NOTE**

Refer to the related procedure in this user's guide for detailed instructions on completing the task.

3.4 Changing the Passwords

Two log ins provide different privileges to card access. "User" gives read-only access while "Admin" allows configuration changes.

To log on as user:

- For firmware 2.6.0.5 and higher the user name is "**user**" and the default password is the card's MAC address (case sensitive with no colons).

For example: Card's MAC address: 00:E0:D8:FF:C0:C4

- User name: user
- Password: 00E0D8FFC0C4

- For firmware versions older than 2.6.0.5 the default username and password is "**user**".

To log in as admin, repeat the user log in above and replace user name with "**admin**".

**NOTE**

The characters in the password fields appear as asterisks (*).

To change the passwords:

1. Click **Access Control** from the Configuration menu.
The Access Control Configuration page displays with the password fields.
2. To change the user password, enter the new password twice (replace existing asterisks) in the **Password for the user account** fields.
To change the admin password, log on as **admin** and enter the new password twice (replace existing asterisks) in the **Password for the admin account** fields.
3. Click **Apply** and then **OK** to save the settings. The logon prompt displays.
4. Log on to the card using the new password.

**NOTE**

You must be logged on as "admin" to configure the card. To prevent unauthorized access after you finish configuring the card, close the browser or log off as admin. To log off as admin, select **Log on as 'user'** from the Configuration menu. Logging on as user sets the security level to read-only.

3.5 Setting the Date and Time

The PXGX UPS card can be configured to synchronize the date and time with one or more NTP servers, or the date and time can be manually set. In addition, temperature unit of measure can be set to display as Fahrenheit or Celsius. Changes made to these fields are updated everywhere they appear.

**NOTE**

All date and time selections are automatically converted to Coordinated Universal Time (UTC).

To set the date and time, and temperature unit of measure:

1. Select **Date/Time** from the Configuration menu.
The default is to synchronize the date and time from the PC clock.
2. To synchronize the card with Network Time Protocol servers, select **Synchronize with NTP server(s)** and type the IP addresses or host names. You can synchronize the card with up to three NTP servers.

The NTP status displays as one of the following:

- **Not running** – Indicates that NTP is not running.
- **Started, not synchronized** – Indicates that NTP is running, but is not yet synchronized with an NTP server or controlling the local clock.
- **Synchronizing with NTP server** – Indicates that NTP has synchronized with the local clock, but is not yet synchronized with an NTP server.
- **Synchronized to XX, NTP stratum YY** – Indicates that the card is synchronized with an NTP server at IP address XX that is operating at NTP Stratum YY.

**NOTE**

When using host names, verify that the IP address of your network DNS Server is configured (see [2.8 Network Configuration](#)).

**NOTE**

When NTP status is Synchronized and there is a large discrepancy between the PXGX UPS Card time and the actual time, it may take 5–30 minutes for NTP to reset the card to the proper time.

3. To set the time manually, select **Set date/time manually** and type or select the local date in mm/dd/yyyy format and the local time in hh/mm/ss format.
4. To customize how the date displays in the card's data and event logs, select a **Date format for logs** option (mm/dd/yyyy, dd/mm/yyyy, yyyy-mm-dd, or dd mmm yyyy). The default is mm/dd/yyyy.
5. To select the time zone for the card, specify the **Time zone for logs, email, and connected device**.
6. To specify how the temperature displays on the Web page, select **Fahrenheit** (default) or **Celsius**.
7. Click **Apply** and then **OK** to save the settings.
8. Refresh the Web page to view the updated formats.

3.6 Configuring SNMP Options

This section describes the following SNMP configuration options:

- Configuring community strings and trap recipients
- Changing SNMP access
- Setting system location and system contact
- Managing from an SNMP NMS

3.6.1 Community Strings and Trap Recipients

The PXGX UPS card supports several event-related traps that can be reported to the SNMP network management software. See [Chapter 6 MIB Files](#) for more information.

To configure the SNMP options:

1. Select **SNMP** from the Configuration menu.

2. SNMPv1 and SNMPv3 are supported and both versions are enabled by default. To modify, clear the check box for the version to be disabled. The fields associated with the disabled version become unavailable (dimmed).
3. For SNMPv1 configuration, type a new community string in the appropriate field to change the community strings.
The default community strings are **public** for read-only, **private** for read-write.
4. For SNMPv3 configuration, enter a new read-only username and password and read-write username and password in the appropriate fields. Passwords for SNMPv3 must be at least 8 characters long.
5. To modify the **Trap recipient community** string field, type a new name. The default is "public".
6. Click **Add** to add a new trap recipient entry to the list. The Recipient field populates with the next available number.
7. Enter the trap recipient IP address or host name in the **IP/hostname** field.

 **NOTE** When using host names, verify that the IP address of your network DNS Server is configured (see [2.8 Network Configuration](#)).

8. Click **Apply** and then **OK** to save the settings.

 **NOTE** Select the Recipient drop-down menu to view all assigned trap recipients.

9. Repeat Steps [Step 6](#) through [Step 8](#) for each additional trap recipient.
10. To remove a trap recipient:
 - a. Click **Delete Last**
 - b. Click **OK** when prompted to remove the settings for the trap recipient entered last.

3.6.2 Changing SNMP Access

The default is to limit access to the card to trusted SNMP NMS hosts only.

To allow access that is unrestricted by hostname (though still qualified by community names or SNMPv3 passwords):

1. Select **Access Control** from the Configuration menu.
2. Clear the check box for **SNMP access restricted by IP/hostname**.
3. Click **Apply** and then **OK** to save the settings.

To add a host to the Trusted Host List for restricted access:

1. Select **Access Control** from the Configuration menu.
2. Verify that the check box for **SNMP access restricted by IP/hostname** is selected.
3. Type the trusted NMS host's IP addresses or host names, separated by a semicolon, in the **Trusted IPs/hostnames** field.

 **NOTE** When using host names, verify that the IP address of your network DNS Server is configured (see [2.8 Network Configuration](#)).

4. Click **Apply** and then **OK** to save the settings.

3.6.3 System Location and System Contact

To set the system location and system contact:

1. Select **Network** from the Configuration menu.
2. Enter the physical location of the installed UPS/card in the **System location** field. This value also displays in the card's Web page banner.
3. Enter the information to identify someone to contact with questions about this device in the **System contact** field. For example, you can type a person's name, phone number, department, e-mail address, physical location, or combination of these items, such as John Smith x123.
4. Click **Apply** and then **OK** to save the settings.

3.6.4 Management from an SNMP NMS

To access the PXGX UPS card using SNMP:

1. Verify that the NMS is configured for the correct community strings or SNMPv3 user names and passwords, as shown on the SNMP Web page. See [3.6.1 Community Strings and Trap Recipients](#).
2. Verify that the NMS is a Trusted Host, or that your PXGX UPS Card is configured for unrestricted SNMP access on the Access Control Configuration Web page. See [3.6.2 Changing SNMP Access](#).
3. Select the **MIB Files** folder from the **Documentation** menu (or visit www.eaton.com/powerxpert) for the following MIB files for the following MIB files for the PXGX UPS Card:

MIB Name	Filename	Description
Powerware UPS MIB	XUPS-MIB.txt	Meters and traps for Eaton UPSs
RFC 1628 UPS MIB	UPS-MIB.txt	Meters and traps for vendor-independent UPSs
Eaton EMP MIB	EATON-EMP-MIB.txt	Meters and settings for the EMP
Eaton Alarms+Traps MIB	EATON-PXG-MIB.txt	Alarms and notifications (traps)
Eaton Object Identifier (OID) assignments	EATON-OIDS.txt	Base document for all OID assignments for Eaton MIBs
RFC 4133 Entity MIB	ENTITY-MIB.txt	Identification and description of each device attached to the card
RFC 4268 Entity State MIB	ENTITY-STATE-MIB.txt	Five availability status meters for each device attached to the card
RFC 4268 Entity State MIB Part 2	ENTITY-STATE-TC-MIB.txt	Possible state values for the Entity State MIB

Add these files to the MIB database of your SNMP management software (such as HP OpenView™ and IBM® Systems Director).

4. Use the facilities provided by the SNMP management software to access the individual MIB objects. See [Chapter 6 MIB Files](#) for more information.

3.7 Configuring Modbus TCP/IP Options

To limit access to the card from trusted Modbus Transmission Control Protocol/Internet Protocol (TCP/IP) addresses only:

1. Select **Access Control** from the Configuration menu.
2. Select the **Modbus TCP access restricted by IP/hostname** check box.
3. Type the trusted host's IP addresses or host names, separated by a semicolon, in the **Trusted IPs/hostnames** field.

**NOTE**

When using host names, verify that the IP address of your network DNS Server is configured (see [2.8 Network Configuration](#)).

- Click **Apply** and then **OK** to save the settings.

For information on Modbus registers, see [Chapter 7 Modbus Registers](#). See [7.2 Returning Error Codes](#) to change how error codes are returned.

3.8 Configuring HTTP and HTTPS

To configure the ports for Hypertext Transfer Protocol (HTTP) and HTTP over Secure Socket Layer (HTTPS):

- Select **Access Control** from the Configuration menu.
- Type the TCP port number for HTTP in the **HTTP port** field (the default is 80).
- Type the TCP port number for HTTPS in the **HTTPS port** field (the default is 443).
- To require a secure connection to the card, select the **Require HTTPS** check box.
- Click **Apply** and then **OK** to save the settings.

3.9 Automatic Shutdown of UPS-Protected Computers

NetWatch client software supports remote UPS monitoring and automatic shutdown of UPS-protected computer systems and is available from www.eaton.com/powerquality under Software Downloads.

Clients are available for many operating systems, including:

- Microsoft Windows
- Novell NetWare®
- Linux®
- UNIX
- Mac OS X

Check www.eaton.com/powerquality for a complete listing of supported operating systems.

Each NetWatch client uses its IP address to register with a specified PXGX UPS Card through the network. After a client has registered, any change in UPS status is communicated to NetWatch. Depending on the operating system, NetWatch typically alerts the user(s) whenever the UPS begins supplying AC power from its batteries (for example, the AC line fails). Then, if AC line power does not return and the remaining battery time is low, NetWatch takes over and completes an operating system shutdown prior to the UPS running out of battery power.

Settings found in the NetWatch Configuration page are related to the automatic shutdown of the UPS-protected computer system using NetWatch.

3.9.1 Configuring NetWatch Shutdowns for a UPS without Load Segments

To configure NetWatch client shutdowns:

- Expand the UPS folder on the Configuration menu and select **NetWatch**.
- The card notifies NetWatch clients when there is a power outage. To modify how long the card waits before sending the message, enter a value between 10 and 600 seconds (10 seconds to 10 minutes) in the **Delay before first AC fail warning message** field. The default is 10 seconds.
- To modify how often the card repeats the power outage notification, enter a value between 30 and 600 seconds (30 seconds to 10 minutes) in the **Warning interval** field, or enter 0 to receive only the initial message. The default is 60 seconds.

4. To enable NetWatch to shut down clients during a power outage, select the **Notify client OS to shutdown on an AC failure** check box.
5. Set the appropriate **Number of seconds the AC failure must last before client is notified to start OS shutdown** to ensure that the NetWatch clients shut down only when there is an extended power outage. To modify, enter a value between 1 and 21600 seconds (1 second to 6 hours). The default is 600 seconds (10 minutes).
6. To turn off power to the UPS output receptacles following the client shutdown:
 - a. Select the UPS **to turn off following OS Shutdown** check box.
If the this check box is not selected, the power remains available to the UPS output receptacles until the UPS battery power is exhausted.
 - b. Set the appropriate number of seconds for the **Delay before output turns off** to ensure that any NetWatch clients and their respective operating systems have enough time to complete their shutdown. The default is 180 seconds (2 minutes), but you may want to increase or decrease this value as appropriate for your system and available battery runtime. To modify, enter a value between 30 and 3600 seconds (30 seconds to 1 hour).
7. To reboot the UPS and the associated load:
 - a. Select the UPS **to restart following the return of AC line** check box.
If this check box is not selected, the UPS remains off (requiring local interaction to turn it back on) when utility power returns.
 - b. Set the time for **Delay before output restart** to a valid delay value to allow the UPS enough time to restart after the specified delay. To modify, enter a value between 10 and 3600 seconds (10 seconds to 1 hour). The default is 30 seconds.
8. Click **Apply** and then **OK** to save the settings.

3.9.2 Configuring NetWatch Shutdowns for UPS with Load Segments

To configure NetWatch client shutdowns, perform the following steps for each load segment you want to modify:

1. Expand the UPS folder on the Configuration menu and select **NetWatch**.
The NetWatch Configuration page displays configuration options. The UPS load segments are shown with configuration options for each segment.
2. The card notifies NetWatch clients when there is a power outage. To modify how long the card waits before sending the message, enter a value between 10 and 600 seconds (10 seconds to 10 minutes) in the **Delay before first AC fail warning message** field. The default is 10 seconds.
3. To modify how often the card repeats the power outage notification, enter a value between 30 and 600 seconds (30 seconds to 10 minutes) in the **Warning interval** field, or enter 0 to receive only the initial message. The default is 60 seconds.

**NOTE**

You can change the name in the Load segment name field. Changes to this field update throughout the PXGX UPS Card Web pages when the settings are saved.

4. To enable NetWatch to shut down clients during a power outage, select the **Notify client OS to shutdown on an AC failure** check box.
5. Set the appropriate **Number of seconds the AC failure must last before client is notified to start OS shutdown** to ensure that the NetWatch clients shut down only when there is an extended power outage. To modify, enter a value between 1 and 21600 seconds (1 second to 6 hours). The default is 600 seconds (10 minutes).

6. To turn off power to the UPS output receptacles following the client shutdown:
 - a. Select the **Load segment to turn off following OS Shutdown** check box.
 If the **Load segment to turn off following OS Shutdown** check box is not selected, the power will remain available to the UPS output receptacles until the UPS battery power is exhausted.
 - b. Set the appropriate number of seconds for the **Delay before segment turns off** to ensure that any NetWatch clients and their respective operating systems have enough time to complete their shutdown. The default is 180 seconds (2 minutes), but you may want to increase or decrease this value as appropriate for your system and available battery runtime. To modify, enter a value between 30 and 3600 seconds (30 seconds to 1 hour).
7. To reboot the UPS and the associated load:
 - a. Select the **Load segment to restart following the return of AC line** check box.
 If the **Load segment to restart following the return of AC line** check box is not selected, the UPS will stay off (requiring local interaction to turn it back on) when utility power returns.
 - b. Set the time for **Delay Before Segment Restart** to a valid delay value to allow the UPS enough time to restart after the specified delay. To modify, enter a value between 10 and 3600 seconds (10 seconds to 1 hour). The default is 30 seconds.

 To stagger the load segment restarts (for sequencing, or to avoid a power surge), enter a different delay time for each load segment.
8. Click **Apply** and then **OK** to save the settings.

3.9.3 Shutdown Clients

The Registered Shutdown Clients area displays the IP addresses of the clients that have registered for the shutdown service. Eaton recommends that each client test the shutdown feature by clicking **Shutdown Test**.



NOTE The **Shutdown Test** command shuts down the client operating system.

3.10 UPS Power Management

The PXGX UPS Card supports the ability to remotely turn off the UPS and its supported load. You can also reboot the UPS (cycling output power off and then back on) and schedule shutdowns and startups on a predetermined basis.

In addition, you may initiate a battery or system test.



NOTE Buttons on the UPS Test and Control page are not available (dimmed) if the UPS does not support that function.

3.10.1 Testing the UPS Battery

To test the battery:

1. Expand the UPS folder on the Configuration menu and select **Test and Control**. The UPS Test and Control page displays. The results from the previous battery test display on the left of the **Start Battery test** button.
2. Select **Start battery test** and click **OK** to confirm.

A failed response indicates that the battery should be replaced. Contact your service representative to order new batteries.

3.10.2 Testing the UPS System

To test the UPS system:

1. Expand the UPS folder on the Configuration menu and select UPS **Test and Control**. The UPS Test and Control page displays.
2. Select **Start system test** and click **OK** to confirm.

For a failed response, refer to the UPS control panel for more information.

3.10.3 Turning the UPS Load Segments On and Off

To turn on and off the load segments on the UPS:

1. Expand the UPS folder on the Configuration menu and select UPS **Test and Control**. The UPS Test and Control page displays.
2. Select the **Enable auto-refresh of UPS state** check box if it is not already selected to view changes in the UPS load segment state as they happen.
3. Click **Shutdown Now** to shut down the selected UPS load segment. Results display to the right of the button.
4. Click **OK** to close the dialog box. The highlighted text reflects the UPS output state.

**NOTE**

NetWatch clients are also shut down, so the shutdowns may be delayed to accommodate the OS shutdown times specified on the NetWatch Configuration Web page.

5. Click **Startup Now** to start the selected UPS load segment. Results display to the right of the button.
6. Click **OK** to close the dialog box. The highlighted text reflects the UPS output state.

3.10.4 Scheduling a UPS Shutdown and Restart

Up to seven UPS shutdown and restart events can be scheduled for any time and day of the week.

**NOTE**

Times and dates for scheduled shutdowns and restarts are based on the local time and date configured for the card. The date and time is displayed in the banner. For more information, see [Setting the Date and Time](#).

**NOTE**

NetWatch clients are also shut down, so the shutdowns may be delayed to accommodate the OS shutdown times specified on the NetWatch Configuration Web page.

To configure scheduled UPS shutdowns:

1. Expand the UPS folder on the Configuration menu and select UPS **Schedule Shutdown**.
2. Select the day, hour, and minutes for the shutdown and restart.

**NOTE**

Do not overlap the scheduled shutdown and restart events.

3. Repeat Step 2 for each event to be scheduled.
4. Click **Apply** and then **OK** to save the settings.
If any of the scheduled shutdown times are not possible, an error message displays on the right.
5. To disable scheduled events, you can deselect one event or select the **Disable all schedules** check box. The event fields dim but the values remain for use later.

6. Click **Apply** and then **OK** to save the settings.

3.11 Configuring E-Mail Notification

The PXGX UPS Card can be configured to send e-mail notification to selected recipients when an event is triggered:

- Configure general e-mail notification to send e-mail messages when any selected event is triggered on the monitored UPS.
- Configure collective e-mail notification to send a single e-mail message instead of one from each affected UPS in the network when input power-related events are triggered.

3.11.1 General E-Mail

You can use the PXGX UPS Card to inform selected e-mail accounts of events and changes in status as they occur in the UPS or to provide a status message at a predetermined time.

To configure e-mail notification:

1. Expand the Email folder on the Configuration menu and select **Email**.
2. Enter the IP address or host name of the **SMTP Server IP/hostname** (mail server) that will be used to send the e-mail messages.
3. If you need to enter a user name and password for the SMTP server:
 - a. Click **Advanced SMTP configuration**

If you have made changes to the Email page, a confirmation box opens. Click **OK** to save the settings; otherwise, click **Cancel**. The Advanced SMTP Configuration page displays.
 - b. Enter the user name and password in the **SMTP username** and **SMTP password** fields.
 - c. Specify a "from" e-mail address in the **SMTP Fromaddress** field (for example, UPS_1@10.222.10.111).
 - d. Click **Apply** to save the settings and return to the General Email Configuration page.
4. Click **Test SMTP server connection** to test the configuration for the SMTP server. The SMTP Test Results window opens. Close the window when you are done viewing.



NOTE

If the SMTP test is successful, the confirmation displays immediately. A failed test response can take longer to display. Close the window if you want to terminate the test.

5. Specify events to trigger an e-mail to be sent to all recipients:
 - a. Click **Configure** to open the Email Event Trigger Configuration page.
 - b. Select **Select All**, **Select All Unbatched**, **De-select All**, or select specific event check boxes to indicate which events are to be included for e-mail notification.
 - c. Click **Apply** and **OK** to save the settings.
 - d. Test the event e-mail function by selecting **Test Event Email**. A sample e-mail is sent for the first trigger event that is selected and saved.
 - e. Select **Email** in the Email folder to return to the Email configuration page.



NOTE

Input power-related events (batched items) are identified by (Input Power Bad) appended to the event name. To avoid receiving duplicate notifications, do not select batched items if Collective Email is enabled and one or more gateways are configured with at least one e-mail recipient for [3.11.2 Collective E-Mail](#).

6. To create a new recipient:
 - a. Select an unassigned number from the **Recipients** list.
 - b. Enter the recipient's e-mail address in the **To** field.
 - c. Click **Apply**. The e-mail address is added to the **Recipients** list.

 **NOTE** Up to ten recipients can be configured to receive event e-mail messages.

7. To modify the options for a recipient, select the e-mail address from the **Recipients** list and select options for the recipient. See [Table 1](#) for a description of options.

Table 1. E-Mail Options for Receiving Event Notification

Option	Description
Send on event active	Sends an e-mail message when an event occurs
Send on event clear	Sends an e-mail message when an event clears
Attach event log file to event emails	Attaches the event log to the event e-mail message (the log is always attached to status e-mail messages)
Attach data log file to event emails	Attaches the data log to the event e-mail message (the log is always attached to status e-mail messages)
Attach interval log file to event emails	Attaches the interval log to the event e-mail message
Attach ID file to event emails	Attaches the identification files to the event e-mail message
Send periodic status emails	Sends periodic status e-mail messages
Days between periodic status emails	Sets the number of days between the periodic status e-mail messages
Time of day (gateway time) for periodic status email (HH:MM)	Sets the time of day for periodic status e-mail messages to be send (in 24-hour format, PXGX UPS Card UTC time)

8. Click **Apply** and then **OK** to save the settings.

 **NOTE** Apply changes before modifying or creating another e-mail recipient.

3.11.2 Collective E-Mail

Use the collective e-mail feature to limit redundant e-mail messages during input power-related events affecting the UPS. When an input power-related event is detected by one or more gateways, event data is shared in real time between gateways and consolidated.

Input power related events are:

- Input AC Over Voltage
- Input Under Or Over Frequency
- Utility Not Present
- Input AC Under Voltage
- UPS On Battery
- Utility Out Of Limits

After a delay of about 30 seconds with no event activity, a single e-mail is sent, detailing the list of input power-related events present and the list of UPSs affected.

Collective e-mail can be configured to send notification from one PXGX UPS Card to some or all recipients, or from several PXGX UPS Cards to some or all recipients, in any combination. Recipients can be set up into logical groups and e-mail addresses are displayed so duplication can be avoided.

To configure collective e-mail event messages:

1. Expand the Email folder on the Configuration menu and select **Email**. The Email configuration page displays. Verify that the IP address of the SMTP server has been configured and, if applicable, that SMTP has been configured. See [3.11.1 General E-Mail](#).
2. Select **Collective Email** from the Email menu. The Collective Email page displays.
3. Select the **Participate in collective notification** check box. When this option is selected, your gateway is visible to peer gateways so that redundant e-mail messages can be combined.
4. Enter the e-mail address of one or more recipients in the **Collective email recipients** field. Verify that the recipient is not already listed in the Visible Peers section that displays at the bottom of the Collective Email page to avoid duplication.

The Visible Peers section lists all gateways in the network that are participating in collective notification (see [Table 2](#) for details).



NOTE A UPS must have a PXGX UPS Card to participate in collective notification.

Table 2. Visible Peers

Column	Description
IP Address	IP address of the PXGX UPS Card
Firmware Version	PXGX UPS Card firmware version
Email Server	IP address of the SMTP server entered on the General Email Configuration page
Email Recipients	E-mail addresses of recipients

5. Click **Apply** and then **OK** to save the settings.

3.12 Configuring EMP Settings

The optional Environmental Monitoring Probe (EMP) allows remote monitoring of the UPS's environment through regular measurements of temperature and humidity through two external contacts.

The EMP is connected to the EMP port directly on the card with a standard Ethernet cable. Recognition is automatic. The Environmental Monitoring Probe selection is added to the Device Data and Configuration menus of the Web interface.

To configure the EMP settings:

1. Select Environmental Monitoring Probe from the Configuration menu.
2. For Contact #1 and #2, enter the **Contact Description**, such as External Contact #1 and External Contact #2.
3. For Contact #1 and #2, select the **Contact Type** as Disabled (never alarm), Normally Open (alarm on close), or Normally Closed (alarm on open) from the pull-down menu. Disabled is the default.

**NOTE**

The NetWatch clients shut down according to the parameters configured on the NetWatch Configuration page (see for shutdown settings).

4. If Contact #1 or Contact #2 alarms remain active for a specified amount of time, you can signal the NetWatch clients to shut down. To specify the amount of time, set the seconds for Contact #1 and #2 in the **OS Shutdown Delay** field. Enter 1 to 600 seconds (1 second to 10 minutes) to enable the shutdown. The default is 0, which means the NetWatch clients will not shut down.
5. To set the temperature alarm limits of the EMP, enter 32 to 158 degrees Fahrenheit (0 to 70 degrees Celsius) for the **Temperature Upper Limit** and the **Temperature Lower Limit**.
6. Use the **Temperature Hysteresis** to control the alarm when the current value is hovering around the limit. When the EMP temperature measure activates the alarm, it can come out of the alarm state only by dropping below the Temperature Hysteresis value. Enter a value between 0 and 10 percent. The default is 2 percent.
7. If the temperature alarm remains active for a specified amount of time, you can signal the NetWatch clients to shut down. To specify the amount of time, set the seconds for the temperature alarm in the **OS Shutdown Delay**. Enter 1 to 600 seconds (1 second to 10 minutes) to enable the shutdown. The default is 0, which means the NetWatch clients will not be shut down.
8. To set the humidity limits of the EMP, enter 0 to 90 percent for the **Humidity Upper Limit** and the **Humidity Lower Limit**. The default for the upper limit is 90; the default for the lower limit is 0.
9. Use the **Humidity Hysteresis** to control the alarm when the humidity percentage is hovering around the alarm limit. When the EMP humidity measure activates the alarm, it can come out of the alarm state only by dropping below the Humidity Hysteresis value. Enter a value between 0 and 20 percent.
10. If the humidity alarm remains active for a specified amount of time, you can signal the NetWatch clients to shut down. To specify the amount of time, set the seconds for the humidity alarm in the **OS Shutdown Delay**. Enter 1 to 600 seconds (1 second to 10 minutes) to enable the shutdown. The default is 0, which means the NetWatch clients will not be shut down.
11. Click **Apply** and then **OK** to save the settings.

3.13 Saving and Restoring Configuration Settings

You can create a backup of the PXGX UPS Card settings and restore them at a later date.

3.13.1 Creating a Backup

To create a backup:

1. Select **Save and Restore** from the Configuration menu.
2. To save the PXGX UPS Card settings and preferences, click **Save gateway configuration**. The card exports an XML file containing the PXGX UPS Card configuration settings.
3. Click **Save** and enter a file name and location to save the XML file.
4. If a blank browser window remains open, close it.

3.13.2 Restoring a Backup

**CAUTION**

Restoring configuration settings overrides all changes made to the configuration settings since the backup file was created.

To restore the configuration settings from a backup file:

1. Select **Save and Restore** from the Configuration menu.

2. Click **Browse** to select the file name and then click **Open**.
3. When prompted, confirm that you want to override the configuration settings with the backup file. Click **OK** or **Cancel**.
4. Update the Web page if the Device Data does not automatically display after the backup is complete.

Configuring the Card

Chapter 4 Operation and Maintenance

This section explains:

- PXGX UPS Card panel details
- Indicator descriptions
- DIP switch settings
- Open alarms
- Generating log files
- Firmware upgrade instructions

4.1 PXGX UPS Card Panel Details

[Figure 27](#) shows the PXGX UPS Card front panel.

Figure 27. PXGX UPS Card Panel Details

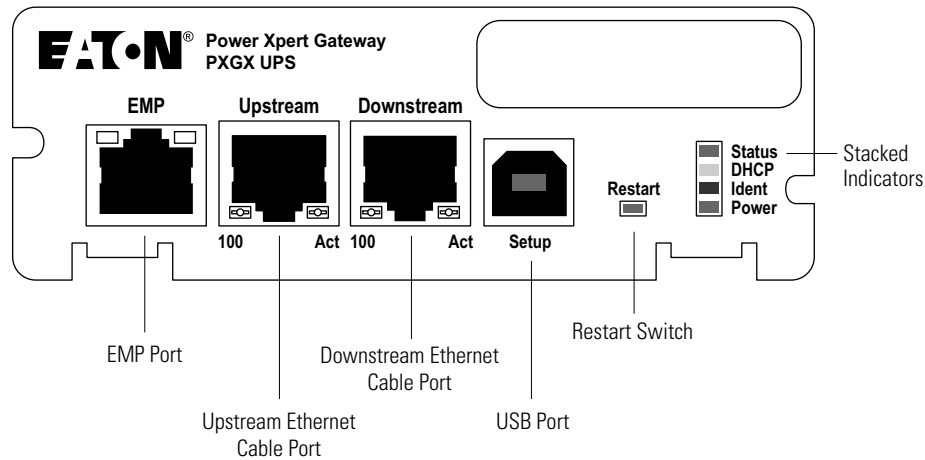

4.2 Indicator Descriptions

The Ethernet port indicator descriptions for the PXGX UPS Card are listed in [Table 3](#). The stacked indicator descriptions are listed in [Table 4](#).

Table 3. Ethernet Port Indicators

	Indicator Label	Illuminated	Not Illuminated
Upstream Ethernet Port	100	Indicates a valid 100 Mb Connection (Link).	Indicates a valid 10 Mb Connection (Link) as long as the corresponding ACT indicator is illuminated.
	ACT	Indicates network activity when the indicator is on or blinking.	Indicates no network activity.
Downstream Ethernet Port	100	Indicates a valid 100 Mb Connection (Link).	Indicates a valid 10 Mb Connection (Link) as long as the corresponding ACT indicator is illuminated.
	ACT	Indicates network activity when the indicator is on or blinking.	Indicates no network activity.

Table 4. Stacked Indicator Descriptions

Label	Color	Illuminated	Not Illuminated
Status	Green	Communication with the UPS has been established.	Communication with the UPS has not been established. As the card boots, the indicator remains off. However, if it remains off after two minutes, there is a communication problem between the card and the UPS.
DHCP	Amber	The PXGX UPS Card is configured for DHCP and has obtained IP address information.	The use of DHCP has been disabled by the user, or PXGX UPS Card has failed to obtain IP address information.
Ident	Red	A firmware update is in progress. Do not remove the card from the UPS.	A firmware update is not in progress.
Power	Green	DC power is available to the card from the UPS.	If all indicators are not illuminated, DC power is not available from the UPS. This may indicate that the UPS is off and unplugged.

NOTE During the power-on sequence, all four indicators illuminate briefly. Wait at least two minutes for the card's boot process to complete before comparing the indicators to the table above because indicators may turn on and off at different times in the boot process.

4.3 DIP Switch Description

DIP switch definitions for the PXGX UPS card are listed in [Table 5](#).

Table 5. DIP Switch Definitions

S1 Position Number	OFF Position (Default)	ON Position
1	Enable previously stored network configuration settings (Normal mode)	Override the existing network settings and assign the local IP address 169.254.1.1.
2	Reserved	Reserved
3	Normal behavior	Reset the HTTP passwords to the defaults on boot (<i>user</i> and <i>admin</i>). After a successful boot, the switch should be turned back off before rebooting the card.
4	Reserved	Reserved
5	Reserved	Reserved
6	Normal behavior	Reset the card to factory defaults on boot (after a successful boot, the switch should be turned back off before rebooting the card again).

4.4 Open Alarms

Alarm notices display in three areas of the Web interface:

- **Banner:** If there is an active alarm(s) present on the UPS (Condition Active: true), a flashing alarm icon and an alarm message display in the banner. The alarm icon and message reflect the actual condition of the highest active alarm in the UPS. Clicking the alarm message displays the Open Alarms page.

- **Device Data Summary and List page:** If there is an open alarm(s), the “(Alarms Present)” message displays at the top of the Device Data Summary and List page and the alarmed data value(s) is highlighted in red text and continues to display in the alarm state until the alarm is closed.
- **Menu bar:** If there is an open alarm(s), “Open Alarms” and the number of active alarms display in red under the Alarms menu. Clicking Open Alarms displays the Open Alarms page.



NOTE An active alarm is different from an open alarm:

- **Active Alarm.** An alarm is active when an alarming condition exists in the UPS. Messages display on the UPS LCD panel and on the card interface banner when alarms go active and disappear when the alarming condition clears.
- **Open Alarm.** When an alarm goes active, it is also considered open and remains open (even after the condition clears in the UPS hardware) until it is closed by an operator. Operators are required to close alarms to ensure that they are seen. While the UPS LCD panel and the card interface banner display the alarms that are active in the UPS, other areas of the card interface (such as the Open Alarms page, device data pages, and the alarm log), display any alarms that have not been closed by the operator. Since closing an alarm that is still active in the hardware quickly results in the generation of a new alarm, an operator has the option to mark an alarm as acknowledged to indicate it has been seen.

The Open Alarms page displays a list of the latest alarms. Inactive alarms continue to display until they are closed.

To view, acknowledge, or close alarms:

1. Select **Open Alarms** from the Open Alarms menu.

The Open Alarms page displays with the following information for each alarm:

- The alarm level (caution, critical, or major).
 - Time and date when the error occurred.
 - The parameter that is in alarm.
 - The alarm message that displays on the UPS control panel (displays as a link).
 - The condition of the alarm (active is true, inactive is false). The condition of the alarm indicates the actual condition of the UPS.
2. To view the specific alarm parameter data, click the Alarm Message link. The Summary page displays and the value in error displays in red text.
 3. Select the alarm or alarms you want to acknowledge, unacknowledge, or close. Select the top check box to select all alarms, or select one or more alarms individually.



NOTE If the Alarm page updates, selections could be lost. Selecting an alarm row, or selecting **Pause Auto-Update**, prevents the page from automatically updating.

4. Select one of the following:
 - a. Select **Acknowledge Selected** to acknowledge that you are aware of the alarm.
 - b. Select **Un-Acknowledge Selected** to reverse a previous acknowledgement.
 - c. Select **Close Selected** to close the alarm and remove it from the Open Alarms list.

-
- NOTE 1** If a UPS alarm is still active in the UPS (Condition Active: true) and you close the alarm, a new alarm and event ID is entered into the Open Alarms list.
- NOTE 2** If a UPS alarm clears automatically, close the alarm to remove it from the Open Alarms list.
-

5. You have the option to add a note when prompted. Click **OK** to apply the selection.

-
- NOTE** This note is optional and is entered into the Event log and displays in the Power Xpert software. The note applies to all selected alarms.
-

6. Click **Continue Auto-Update** to resume page updating.

4.5 Generating Log Files

-
- NOTE** Log files are comma-separated values (*.csv) files that can be opened using Microsoft Excel® software. Some computer configurations automatically open the files with the Microsoft Excel software instead of prompting you to save the file. Excel may default to a date format specific to the country the product is being used in, overriding the card specified format.
-

4.5.1 Data Log

The data log contains a history of the data value changes recorded by the gateway. To generate a data log:

1. Select **Data Log** from the Logs menu.
2. To limit the number of records, type or select one or more of the following optional values:
 - Maximum number of records to return
 - Start Date
 - End Date
3. Click **View log**.
4. Select a name and location for the file (if you chose to save the file when prompted).

4.5.2 Interval Log

The interval log contains a set of samples of data values taken at regular intervals by the gateway. To generate an interval log:

1. Select **Interval Log** from the Logs menu.
2. Select the name of the device.
3. Select the interval (5, 15, or 60 minutes).
4. To limit the number of records, type or select one or more of the following optional values:
 - Maximum number of records to return
 - Start Date
 - End Date
5. Click **View log**.

**NOTE**

The Output KW Hours is recorded on the Interval Log. Because the Output KW Hours is reset to zero when the card is restarted, Eaton recommends that this feature not be used for billing purposes. If you choose to use this value for billing purposes, record the Output KW Hours before restarting the card.

6. Select a name and location for the file (if you chose to save the file when prompted).

4.5.3 Event Log

The event log contains a history of the events recorded by the gateway. To generate an event log:

1. Select **Event Log** from the Logs menu.
2. To limit the number of records, enter one or more of the following optional values:
 - Maximum number of records to return
 - Start Date
 - End Date
3. Click **View log**.
4. Select a name and location for the file (if prompted to save).

4.5.4 System Log

The system log contains the history of the gateway administration activity. To generate a system log:

1. Select **System Log** from the Logs menu.
2. To limit the number of records, enter one or more of the following optional values:
 - Maximum number of records to return
 - Start Date
 - End Date
3. Click **View log**.
4. Select a name and location for the file (if prompted to save).

4.5.5 Erasing a Log

To erase a data, interval, event, or system log:

1. Click **Erase log** from the Data Log, Interval Log, Event Log, or System Log page.
2. Click **OK** to erase the log; otherwise, click **Cancel**.

4.6 Upgrading Firmware

The PXGX UPS card firmware can be updated by downloading the appropriate file from **www.eaton.com/powerxpert**. During the upgrade process, the PXGX UPS card does not monitor the UPS status.

To upgrade the firmware:

1. Select **Firmware** from the Configuration menu.
2. Select the **Reboot when complete** check box to automatically reboot after updating the firmware.

**NOTE**

If the **Reboot when complete** check box is not selected, you will be prompted to select **Reboot** when the update is done.

3. Click **Browse**.

4. Download the pxgx_ups_xxx.rom firmware file, available on the Web at www.eaton.com/powerxpert.
The Web page reloads when the firmware upgrade is complete.

**NOTE**

When saving the file, keep the default file name.

Chapter 5 Root Certificate Authority Installation

Improve the security of your PXGX UPS Card on the Web by installing its root certificate authority (CA) into your browser's CA cache. A CA is a trusted third party that issues digital certificates for use with encrypted digital transactions. The digital certificate guarantees the identity of the Web site of the company that holds the certificate. In this case, the PXGX UPS Card functions as both the CA and the certificate holder.

You can use the card without installing its root CA (using HTTP), but the transactions will not be as secure as with the root CA (using HTTPS). You can require secure transactions by configuring the card for HTTPS (see [3.8 Configuring HTTP and HTTPS](#)). The performance of the card is not impacted by using secure transactions.

This section explains root CA installation for:

- Windows Internet Explorer 7 and Internet Explorer 8
- Mozilla Firefox
- Google Chrome

5.1 Installing Root CA with Windows Internet Explorer 7 and Internet Explorer 8

To install a certificate for the PXGX UPS Card with Windows Internet Explorer 7 or Internet Explorer 8:

1. Open the browser and type the IP address of the card followed by the path /ca.html in the address bar. For example: `http://10.222.49.63/ca.html`.

The Root CA Installation page displays (see [Figure 28](#)).

Figure 28. Internet Explorer – Root CA Installation Page

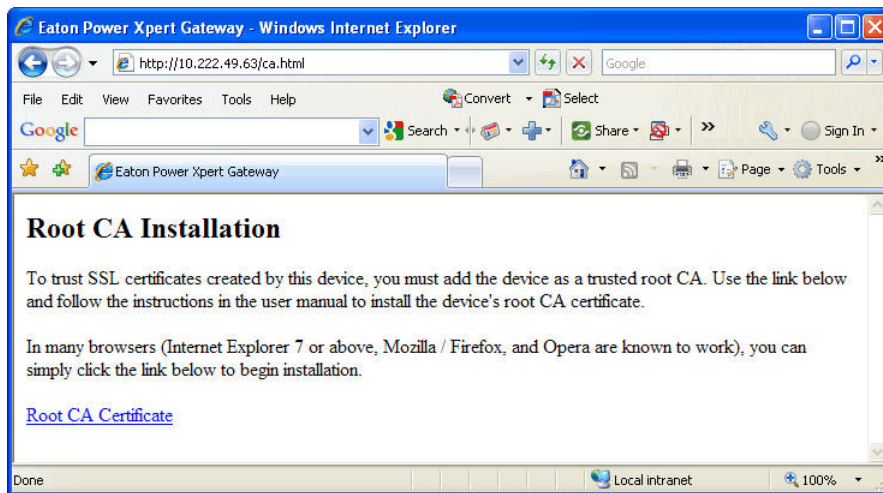

2. Click **Root CA Certificate**.

A File Download warning message displays (see [Figure 29](#)).

Figure 29. File Download Warning

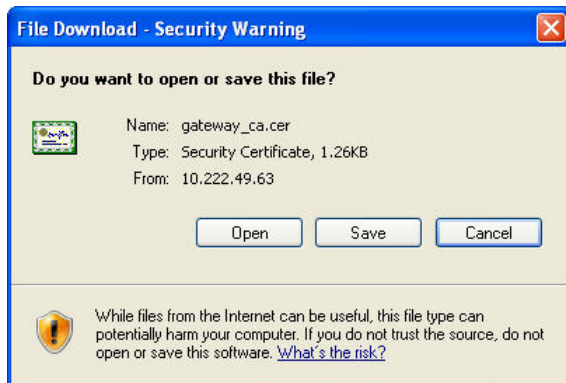

3. Click **Open**.

The Certificate Window opens (see [Figure 30](#)).

Figure 30. Certificate Window for the PXGX UPS Card

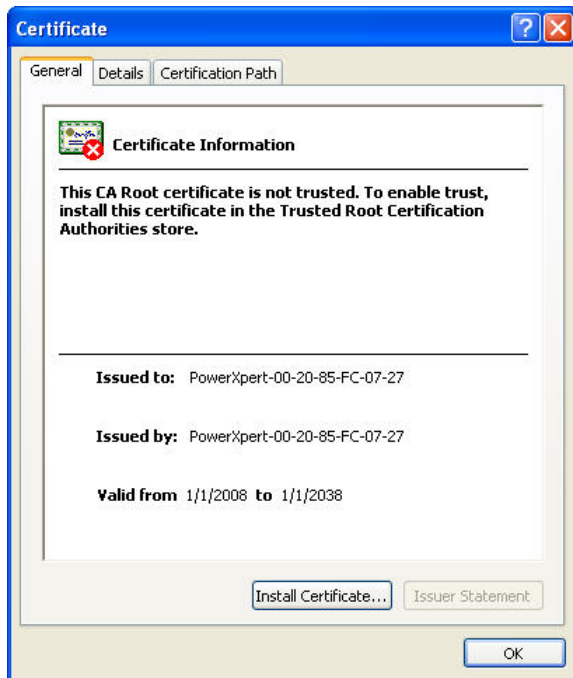

4. Click **Install Certificate**.

The Certificate Import Wizard opens (see [Figure 31](#)).

Figure 31. Certificate Import Wizard

5. Click **Next**.

The Certificate Store window opens, prompting you to specify a certificate store (see [Figure 32](#)).

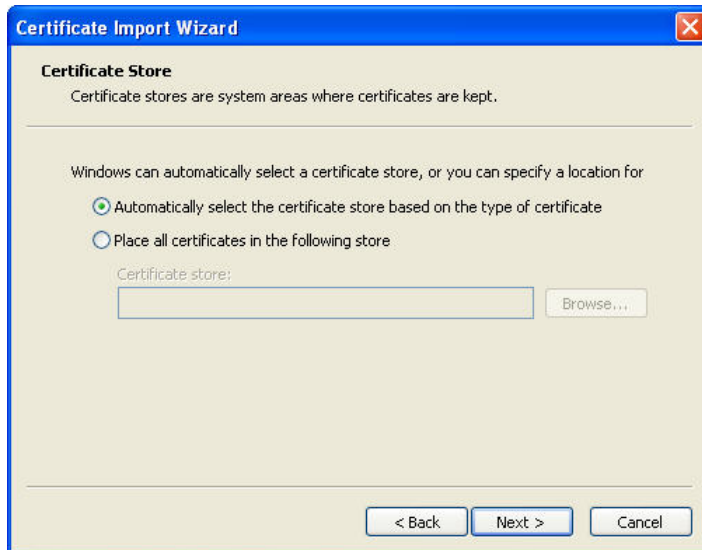
Figure 32. Certificate Store Window

6. Verify that the default setting, **Automatically select the certificate store ...**, is selected.
7. Click **Next**.

The Certificate Import Wizard displays a final verification (see [Figure 33](#)).

Figure 33. Verifying the Certificate Import Settings

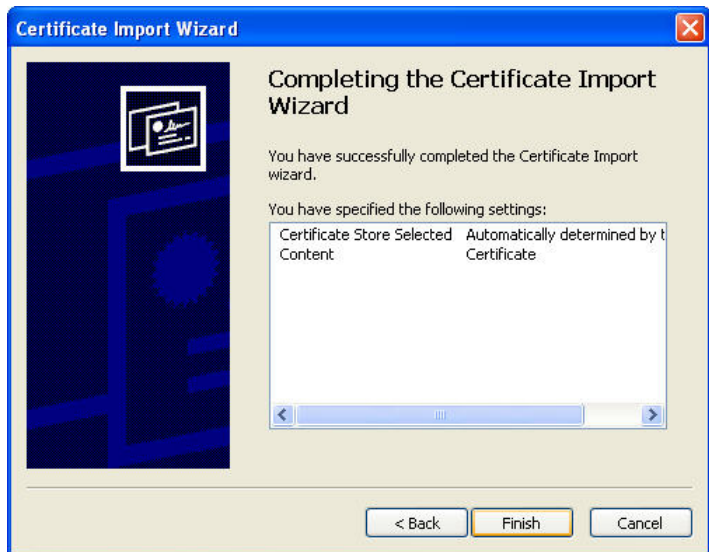

8. Click **Finish** to complete the wizard.

A message displays informing you that Windows will automatically trust any certificate issued by this CA (see [Figure 34](#)).

Figure 34. Security Warning Message

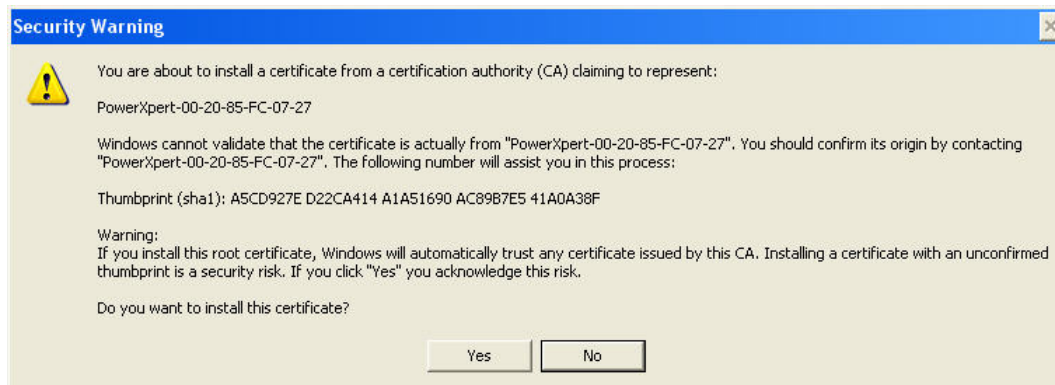

9. Click **Yes** to install the CA.

A new message displays to verify that the import was successful.

10. Click **OK** to close the message.

11. Click **OK** to close the Certificate window.

12. The installation process is complete. You can now access the card using the HTTPS protocol (for example, `https://10.222.49.63`).

13. To view the certificate:

- a. Select **Internet Options** from the **Tools** menu.

- b. Click the **Content** tab.
- c. Click **Certificates**.
- d. Click the **Trusted Root Certification Authorities** tab, and then locate and select the certificate name on the list (see [Figure 35](#)).

NOTE The name of the certificate starts with “PowerXpert” followed by the MAC address of the card.

Figure 35. Trusted Root Certification Authorities Tab

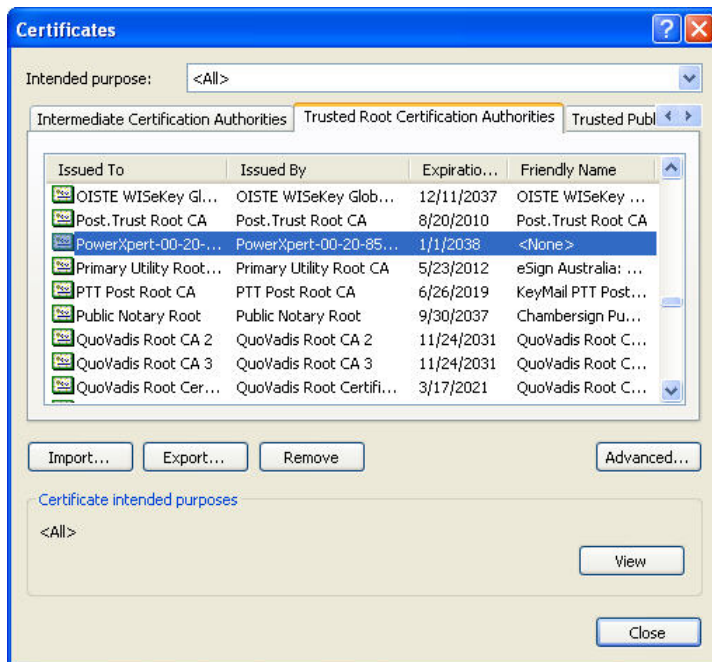

- e. Click **View** to open the Certificate window (see [Figure 36](#)).

Figure 36. View Certificate Window

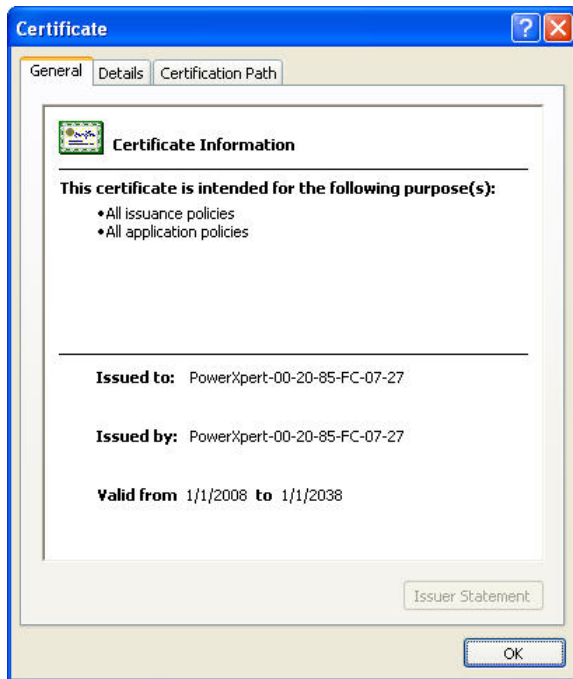

- f. When you are finished viewing the information, click **OK** to close the Certificate window, click **Close** to close the Certificates window, and click **OK** to close the Internet Options window.

5.2 Installing Root CA with Mozilla Firefox

To install a certificate for the PXGX UPS Card with Mozilla Firefox:

1. Open the browser and type the IP address of the card followed by the path **/ca.html** in the address bar. For example: `http://10.222.49.63/ca.html`. The Root CA Installation Window opens (see [Figure 37](#)):

Figure 37. Mozilla Firefox – Root CA Installation Window

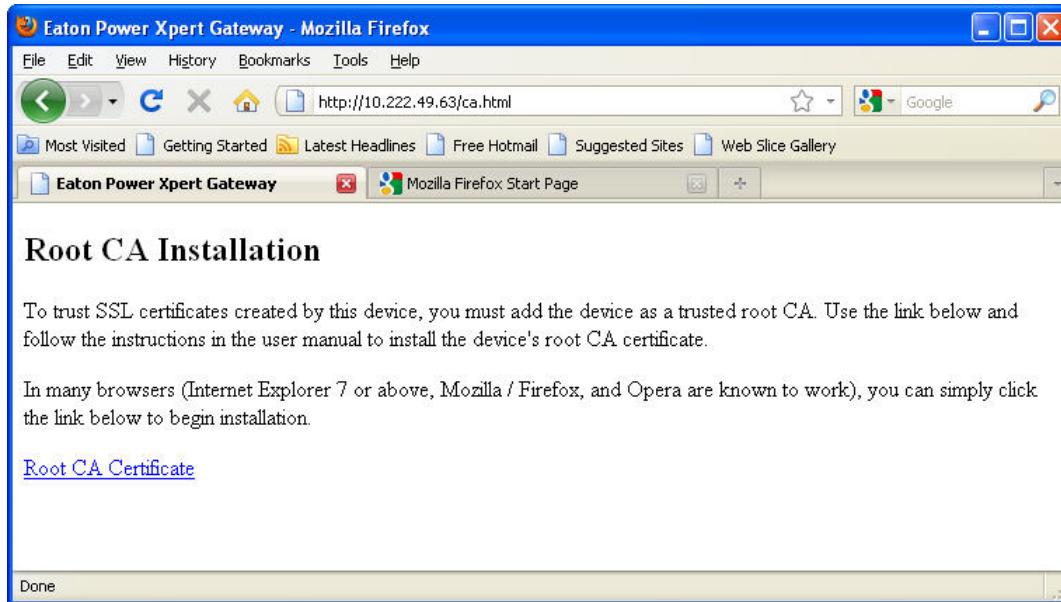

2. Click **Root CA Certificate**. The Downloading Certificate window opens (see [Figure 38](#)).

Figure 38. Downloading Certificate Window



3. If desired, click **View** to manually examine the contents of the certificate.
4. Select the **Trust this CA to identify web sites** check box.
5. Click **OK**. The installation process is complete. You can now access the card using the HTTPS protocol (for example, `https://10.222.49.63`).

5.3 Installing Root CA with Google Chrome

To install a certificate for the PXGX UPS Card with Google Chrome:

1. Open the browser and type the IP address of the card followed by the path `/ca.html` in the address bar. For example: `http://10.222.49.63/ca.html`.

Root Certificate Authority Installation

The Root CA Installation Window opens (see [Figure 39](#)):

Figure 39. Google Chrome – Root CA Installation Window.

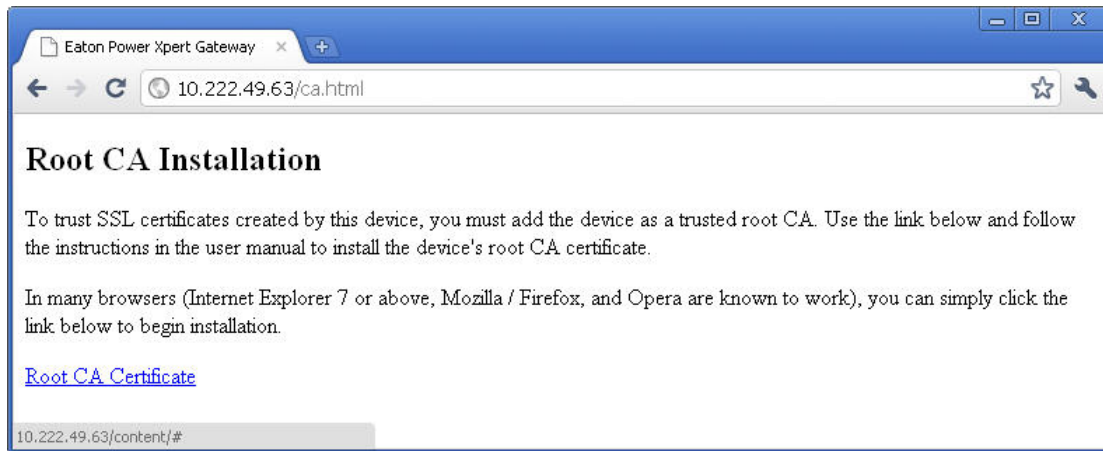

2. Click **Root CA Certificate**.

A File Download warning message displays at the bottom of the window (see [Figure 40](#)).

Figure 40. File Download Warning

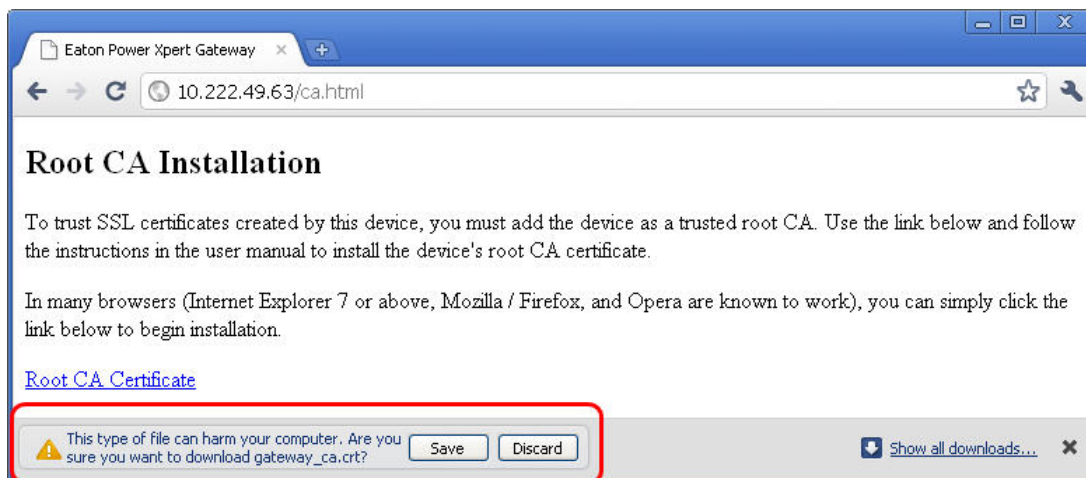

3. Click **Save**.

The CRT (Security Certificate) file name displays at the bottom of the window (see [Figure 41](#)).

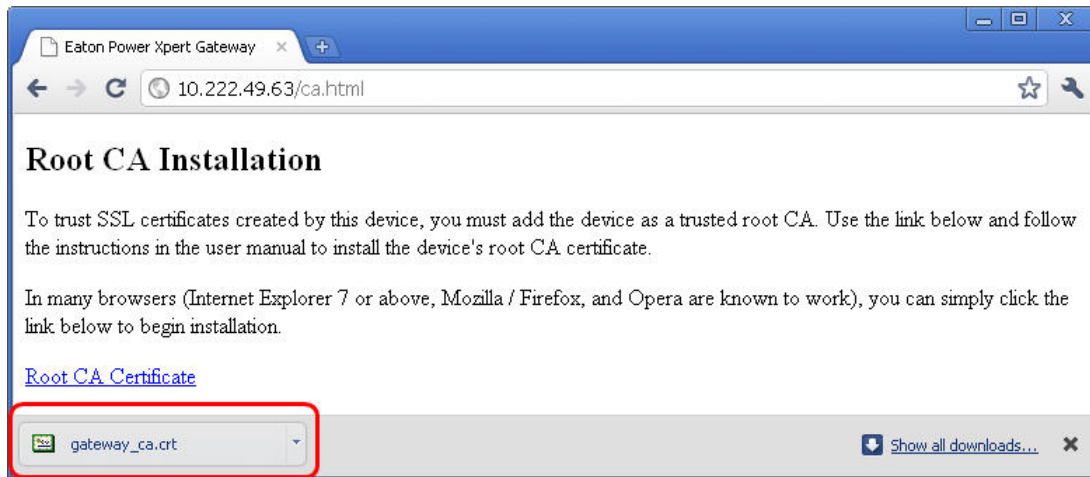
Figure 41. Security Certificate File

4. Click **gateway_ca.crt**.

An Open File warning message displays (see [Figure 42](#)).

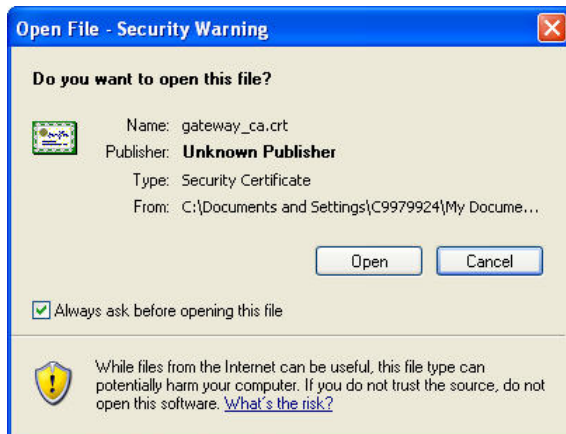
Figure 42. Open File Warning

5. Click **Open**.

The Certificate Window opens (see [Figure 43](#)).

Figure 43. Certificate Window

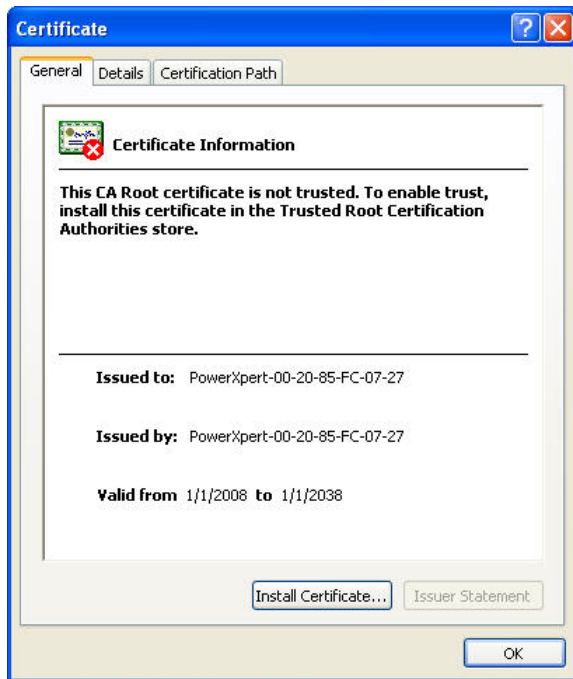

6. Click **Install Certificate**.

The Certificate Import Wizard – Welcome window opens (see [Figure 44](#)).

Figure 44. Certificate Import Wizard – Welcome Window

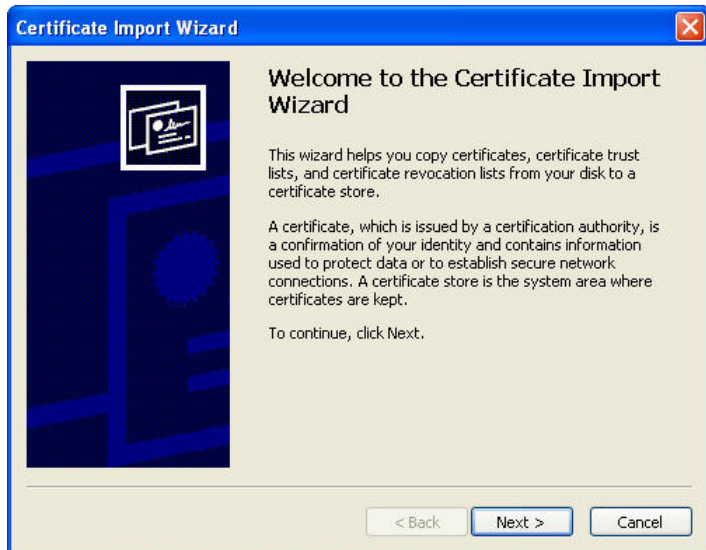

7. Click **Next**.

The Certificate Import Wizard – Certificate Store window opens, prompting you to specify a certificate store (see [Figure 45](#)).

Figure 45. Certificate Import Wizard – Certificate Store Window

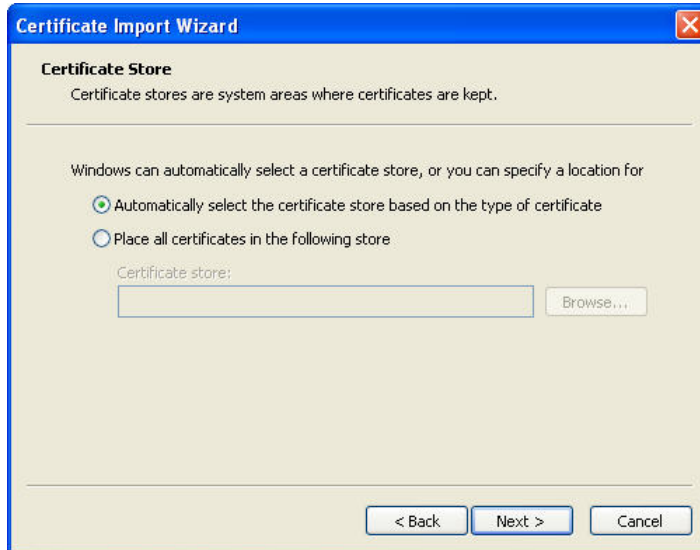

8. Verify that the default setting, **Automatically select the certificate store ...**, is selected.
9. Click **Next**.

The Certificate Import Wizard – Completing the Certificate Import Wizard window certificate displays a final verification (see [Figure 46](#)).

Figure 46. Certificate Import Wizard – Completing the Certificate Import Wizard Window



10. Click **Finish** to complete the wizard.

11. Click **Yes** to install the CA. A new message displays to confirm that the import was successful.
12. Click **OK** to close the message.
13. Click **OK** to close the Certificate window.

The installation process is complete. You can now access the card using the HTTPS protocol (for example, `https://10.222.49.63`).

- a. On the **Wrench**  menu, click **Options**, and then click the **Under the Hood** tab.
- b. Scroll to the bottom of the window and click **Manage Certificates**.
- c. Click the **Trusted Root Certification Authorities** tab and locate and select the certificate name on the list (see [Figure 47](#)).



NOTE The name of the certificate starts with "PowerXpert" followed by the MAC address of the card.

Figure 47. Certificates Window – Trusted Root Certification Authorities Tab

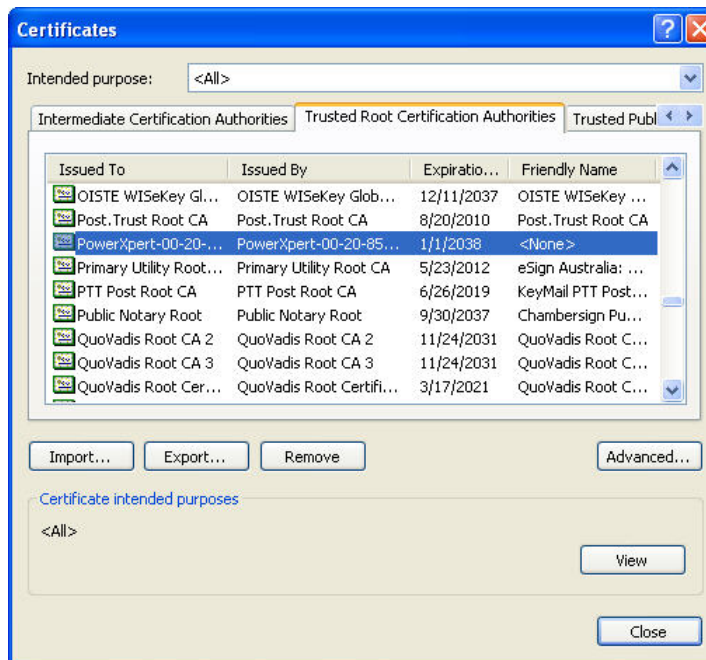

- d. Click **View** to open the Certificate window (see [Figure 48](#)).

Figure 48. Certificate Window

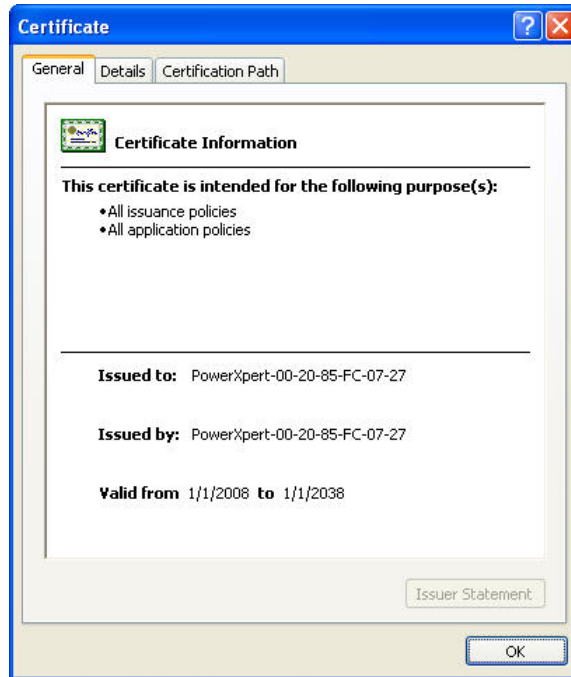

- e. When you are finished viewing the information, click **OK** to close the Certificate window, click **Close** to close the Certificates window, and click **Close** again to close the Google Chrome Options window.

Chapter 6 MIB Files

This chapter describes the Management Information Base (MIB) files available with the card. An MIB is an information repository residing on a device in a communication network. Network management software uses a device's MIB to manage the device. Every manageable device on a network has a MIB consisting of one or more files that list information about the device.

Use the facilities provided by your Simple Network Management Protocol (SNMP) management software to access the individual MIB objects. The objects define the information available about your UPS.

You can configure a device so that it generates a trap if a certain condition occurs, such as an alarm clearing. The trap is sent to the management station to inform it of the occurrence.

This chapter contains an overview of MIB definitions for each of the MIB files:

- Powerware UPS MIB
- RFC 1628 UPS MIB
- Eaton EMP MIB
- Eaton Alarms+Traps MIB
- Eaton OID Assignments
- RFC 4133 Entity MIB
- RFC 4268 Entity State MIB
- RFC 4268 Entity State MIB Part 2

See the MIB files for detailed information about each MIB object.

6.1 Selecting a UPS MIB File

You can use the Standard UPS MIB, as described in RFC-1628, or the proprietary Powerware UPS MIB with the client SNMP management software. Eaton recommends loading both MIBs. Table 6 lists the advantages of both MIBs.

Table 6. UPS MIB Comparison

Standard UPS MIB	Powerware UPS MIB
Works with UPS SNMP agents from many vendors	Downward compatible with existing ConnectUPS cards or adapters
Includes some objects not found in Powerware UPS MIB: upsBatteryStatus upsConfigAudibleStatus upsConfigInputFreq upsConfigLowBattTime upsConfigOutputVA upsIdentAttachedDevices upsIdentName upsSecondsOnBattery	Includes some objects not found in Standard UPS MIB: Environment Group (xupsEnvironment) Receptacle Group (xupsRecep) Topology Group (xupsTopology) xupsBatteryAbmStatus xupsBatteryLastReplacedDate xupsConfigInstallDate xupsControlToBypassDelay xupsHeartbeatMinsInterval xupsSendTrapType
Enhances the Test and Control groups	More trap types and trap descriptions Simpler battery test procedure

6.2 Powerware UPS MIB



NOTE

Not every UPS model implements all of the Powerware UPS MIB objects. For example, the Bypass objects are supported only by larger UPSs with a separate bypass feed.

The Powerware UPS MIB consists of the following groups:

- Identification – the xupsIdent status objects provide UPS information, such as the UPS model or UPS firmware version.
- Battery – the xupsBattery status objects provide UPS battery information, such as battery time remaining or the percentage of battery charge.
- Input, Output, and Bypass – the xupsInput, xupsOutput, and xupsBypass status objects allow the network manager to check or graph the condition of the UPS and its environment, such as monitoring input voltage and output load.
- Environment – the xupsEnvironment objects provide data around the UPS, such as the ambient temperature, and also allow you to set the upper and lower limits for the ambient temperature alarm.
- Alarms and Traps – the xupsAlarm and xupsTrapControl objects alert the SNMP management station to the condition of the UPS and of significant conditions, such as Shutdown Imminent.
- Test – the xupsTest objects perform a general UPS systems test and UPS battery test.
- Control – with the xupsControl objects, a network manager can remotely control the UPS by SNMP set commands, performing such tasks as shutting down or turning on the UPS.
- Configuration – the xupsConfig objects allow you to view UPS configuration, such as watts, voltage, or frequency and configure the UPS date and time and installation date.
- Receptacle – the xupsRecep objects provide status information about the controllable load groups and control objects for removing and returning power to these load groups.
- Topology – the xupsTopology objects describe the machine type and are primarily used for machine-to-machine communication within a power management system.

6.3 RFC 1628 UPS MIB

The RFC 1628 standard UPS MIB consists of the following groups:

- Identification – the upsIdent status objects provide UPS information, such as the UPS model or UPS firmware version.
- Battery – the upsBattery status objects provide UPS battery information, such as battery time remaining or the percentage of battery charge.
- Input, Output, and Bypass – the upsInput, upsOutput, and upsBypass status objects allow the network manager to check or graph the condition of the UPS and its environment, such as monitoring input voltage and output load.
- Alarms – the upsAlarm objects alert the SNMP management station to the condition of the UPS and of significant conditions, such as Shutdown Imminent; this group also lists well-known UPS alarm conditions.
- Test – the upsTest objects perform UPS diagnostic testing and provide the test results; this group also lists well-known UPS diagnostic tests.
- Control – with the upsControl objects, a network manager can remotely control the UPS by SNMP set commands, performing such tasks as shutting down or turning on the UPS.
- Configuration – the upsConfig objects allow you to view UPS configuration, such as watts, voltage, or frequency; for UPSs that allow read-write control for objects in this group, you can also remotely configure UPS parameters, such as input voltage or output frequency.

6.4 Eaton EMP MIB

Objects in this group are provided by the Environmental Monitoring Probe (EMP) and include temperature and humidity readings, alarming limits, the two contacts readings, and setup information. The group contains a table of values for environmental contact sensing (normally two digital inputs for monitoring all contacts).

Traps are sent in response to EMP changes to indicate the type of alarm, alarm acknowledgement, and alarm clearing.

6.5 Eaton Alarms+Traps MIB

Eaton Alarms+Traps MIB Objects in this group provide a table of active alarms and a count of alarms currently active. The notification traps provided are triggered by the publishing of an alarm or event.

6.6 Eaton OID Assignments

These objects document all the object identifier assignments for Eaton products.

6.7 Entity MIB Files

The objects in these MIB files provide information standard in the industry:

- The RFC 4133 Entity MIB provides standard objects for identifying and describing devices attached to the card.
- The RFC 4268 Entity State MIB provides availability status measures for each device.
- The RFC 4268 Entity State MIB Part 2 provides possible state values for the Entity State MIB.

6.8 Selecting the UPS Trap Type

Use the Powerware UPS MIB `xupsSendTrapType` object to select the primary type of traps to be sent to the configured trapsinks when UPS alarms occur or clear. There are three types of traps: `stnd(1)`, `xups(2)`, and `pxg(5)`. See [Table 7](#) for trap comparison.

Table 7. UPS Trap Type Comparison

xupsSendTrapType Options	stnd(1)	xups(2)	pxg(5)
MIB File that Sends Traps	RFC 1628 UPS MIB (UPSMIB.txt)	Powerware UPS MIB (XUPSMIB.txt)	Eaton Alarms+Traps MIB (EATONPXG- MIB.txt)
Number of Defined Traps for Alarms and Notices	Only three: <ul style="list-style-type: none"> • <code>upsTrapOnBattery</code> • <code>upsTrapAlarmEntryAdded</code> • <code>upsTrapAlarmEntryRemoved</code> 	Up to 50; each well-known Powerware UPS MIB alarm is mapped to a trap.	Eleven, with one trap sent for each entry in the PXGX UPS Card Active Alarms table. Each trap indicates its severity level.
Advantages	Simplest set of traps.	<ul style="list-style-type: none"> • Breaks out the alarms into individual traps, and adds a text message describing the UPS alarm. • Auto-clearing alarm types. 	<ul style="list-style-type: none"> • Comparable to other Eaton Power Xpert Gateway products and parallels the BACnet/WS events logged by the Power Xpert software. • Fullest text description for each alarm.

Table 7. UPS Trap Type Comparison (Continued)

xupsSendTrapType Options	stnd(1)	xups(2)	pxg(5)
			<ul style="list-style-type: none"> Includes traps when you acknowledge and close the alarms (see 4.4 Open Alarms).
Disadvantages	You must decode the upsAlarmDescr object ID to determine which alarm has occurred.	None.	<ul style="list-style-type: none"> If five UPS alarms occur for an On Battery condition, it will send five traps. Alarm Cleared traps will not be sent until you acknowledge and close each alarm (see 4.4 Open Alarms).
Traps that are Sent Regardless of Trap Type Setting	upsTrapTestCompleted	<ul style="list-style-type: none"> xupstdCommunicationsLost xupstdCommEstablished 	powerChainEvent (for example, StructureChanged events)

Chapter 7 Modbus Registers

This chapter describes the UPS data that is available through the Modbus TCP/IP protocol. The UPS monitors several parameters, such as voltage, current, power, and alarms. The value of each parameter is stored in a corresponding Modbus data register.

The values of the parameters can be read over an Ethernet network by using Modbus TCP/IP building management programs or Modbus TCP/IP analyzer programs.



NOTE

If your Modbus program requires one-based addressing, add a one to the register addresses listed in [Table 10](#). For example, one-based addressing for the vendor name would be 1033 (1032 + 1). One-based addressing is the default setting for the PXGX UPS.

7.1 Obtaining the Modbus Register Map

To view a list of the Modbus registers in your UPS:

1. Select **Modbus TCP Register Maps** from the Documentation menu.
2. Select the hardware type from the **Select a map to generate** pull-down menu.
3. Most Modbus-TCP clients automatically decrement addresses by one before using them. If your client does not alter addresses in this way, clear the **Use 1-based addressing** check box.
4. Click **View Register Map**. A dialog box opens.
5. Click **Open** to view or **Save** to save the file.



NOTE

The Modbus file is a comma-separated values (*.csv) file that can be opened in Microsoft Excel software. Some computer configurations automatically open the files in the Microsoft Excel software instead of prompting you to save the file.

6. If you select **Save**, select a location for the pxgx-modbus-uid-XXX.csv file, where XXX is the UnitID of the requested map.



NOTE

Some browsers leave a blank window open after you save or view the file. Close the window.

7.2 Returning Error Codes

By default, the PXGX UPS card returns a Modbus error code when it receives an incoming register/discrete/coil READ request for an address that is not currently valid. To improve performance in some situations, you can configure the card to disable this error response and instead return zero-filled data in all of the invalid address ranges.

To change how error codes are returned:

1. Select **Modbus TCP** from the configuration menu.
2. Clear the **Return (vs. zeros) error on unsupported read request** check box to disable the error code or select the check box to enable the error code.
3. Click **Apply** and then **OK** to save the setting.

7.3 Modbus Register Addressing

This section describes Modbus function codes, data formats, and data addressing.

7.3.1 Modbus Function Codes

The UPS registers are read using Modbus Function Codes (FC). For most UPS registers, FC 04 is used. For alarms, FC 02 is used. The UPS supports the following hex function codes:

Table 8. Function Codes

FC	Hex	Description	Use
01	0x01	Read Coil Status	Supported for compatibility purposes; returns the same data as FC 02
02	0x02	Read Discrete Inputs	Single input data, such as alarms and discrete contacts
03	0x03	Read Holding Registers	Supported for compatibility purposes; returns the same data as FC 04
04	0x04	Read Input Registers	Analog data (most string and numeric data types), such as voltage
05	0x05	Write Single Coil	For future use
06	0x06	Write Single Register	For future use
07	0x0F	Write Multiple Coils	For future use
08	0x10	Write Multiple Registers	For future use

7.3.2 Data Formats

Modbus programs usually provide an option for viewing various data types. Refer to your Modbus program documentation for detailed information on viewing data options.

A register is 16 bits (two bytes). The UPS supports the following data types:

- **STRING** – A string of ASCII characters (two per register). Consult the Size parameter to find the string's length for a given entry (it is a multiple of two so that entries are register-aligned).
- **FLOAT** – A 32-bit IEEE754 floating point number. FLOATs are always two registers.
- **UINT** – An unsigned integer. Consult the Size parameter to find the integer's size (in bytes) for a given entry (it is a multiple of two so that entries are register-aligned).
- **TIME** – The TIME type (ym dh ms) consists of six bytes specifying the year, month, day, hour, minutes, and seconds. The bytes are stored in hexadecimal format. If your Modbus application displays the individual bytes in a register, view the bytes using the decimal option. Otherwise, the bytes are best viewed by displaying the two-byte register in a binary format and translating each byte to decimal.

For example, if today is May 17, 2010 and the time is 10:45 and 20 seconds, viewing each byte in decimal would yield the following data, which is viewable as the year (10), month (05), day (17), hour (10), minutes (45), and seconds (20):

10 05	17 10	45 20
-------	-------	-------

See [7.7 Time or Date \(FC 04\)](#) for more information.

- **BOOL** – A binary (Boolean) value of 0 or 1. BOOL is usually assigned to discrete input alarms.

7.3.3 Data Addressing

If a data type spans multiple registers (such as a FLOAT), lower addressed registers map to higher-order parts of the value. Within each register, data is in most significant bit (MSB) first format.



NOTE 1 A Modbus register contains two bytes. Therefore, the number of registers containing the information can be obtained by dividing the bytes by two. For example, the vendor name in [Table 11](#) can be obtained by reading 32 Modbus registers starting at register 1032.

NOTE 2 If a register is not supported in a particular device, an exception response is returned.

7.4 UPS Unit ID Numbers

The Unit IDs associated with the Modbus registers apply to specific load groups or segments (see [Table 9](#)).

The UPS has a Unit ID of 0, 1, or 255, while load groups or segments within the UPS have Unit IDs that range from 2 to 65 (for load groups or segments 1 to 64).

If an optional Environmental Monitoring Probe (EMP) installed, use Unit ID 254 to obtain EMP data. See [7.6 EMP \(FC 04\)](#) for more information.

Table 9. UPS Unit ID Numbers

Unit ID	Description
0, 1, 255	UPS Summary Data
2–65	Load Groups or Segments Data
254	Environmental Monitoring Probe

7.5 UPS Registers and Alarms

This section contains information for the UPS Registers (FC 04) and UPS Alarms (FC 02).

7.5.1 UPS Registers (FC 04)

[Table 10](#) provides a partial list of data registers that are available from a UPS. Not all registers may be available in your UPS or in selected load groups.

To read the vendor name in the UPS, set the Modbus program to Unit ID 1 and register 1032:

IP: <IP address of UPS>

Unit ID: 1

Starting Register: 1032

Number of registers: 32

Function Code: 04

The UPS returns 32 registers containing up to 64 characters. There are two ASCII characters per register, so the vendor name could be displayed as EATON.

To read the UPS output voltage from Phase C to Neutral, set the Modbus program to Unit ID 1 and register 4050:

IP: <IP address of UPS>

Unit ID: 1

Starting Register: 4050

Number of Registers: 2

Function Code: 04

The UPS returns a floating point value of the output voltage from Phase C to Neutral (such as 120.7 volts) of the UPS at the specified IP address.

Table 10. UPS Sample Registers (FC 04)

Parameter Name	Display Name	Register	Discrete	Units	Data Type	Bytes
VendorName	Vendor Name	1032	No	No	STRING	64
ModelName	Model Name	1064	No	No	STRING	64
iDisplayName	Display Name	1096	No	No	STRING	64
iDeviceType	Device Type	1128	No	No	STRING	64
iDeviceID	Device ID	1192	No	No	STRING	64
iDeviceGuid	Device GUID	1256	No	No	STRING	40
SerialNumber	Serial Number	1276	No	No	STRING	64
SoftwareVersion	Software Version	1308	No	No	FLOAT	4
mACVoutC	Vcn Output	4050	No	Volts	FLOAT	4
mACVbypassA	Van Bypass	4058	No	Volts	FLOAT	4
mACVbypassB	Vbn Bypass	4060	No	Volts	FLOAT	4
mACVbypassC	Vcn Bypass	4062	No	Volts	FLOAT	4
mDCVbatt	DCV Batt	4377	No	Volts	FLOAT	4
mAClinA	IinA	5022	No	Amperes	FLOAT	4
mAClinB	IinB	5024	No	Amperes	FLOAT	4
mAClinC	IinC	5026	No	Amperes	FLOAT	4
mACIoutA	IoutA	5028	No	Amperes	FLOAT	4

7.5.2 UPS Alarms (FC 02)

[Table 11](#) provides a partial list of example UPS alarms. Your UPS may have different alarms. UPS alarms are not registers, but are discrete inputs and are read using FC 01 or FC 02.

The UPS monitors the condition of several parameters and can activate an alarm status if a parameter is out of range. For example, if the utility power is too high or too low, the UPS can set the Utility Out of Limits alarm.

To read the Utility Out of Limits alarm, set the Modbus program to Unit ID 1 and discrete address 1057:

```
IP: <IP address of UPS>
```

```
Unit ID: 1
```

```
Starting Address: 1057
```

```
Number of Addresses: 1
```

```
Function Code: 02
```

The UPS returns a BOOL value (0 or 1), indicating if the alarm is active or not active. A return value of 0 (false) indicates an inactive alarm (the utility input is within limits). A return value of 1 (true) indicates an active alarm (the utility input is out of limits).

Table 11. UPS Sample Alarms (FC 02)

Parameter Name	Display Name	Address	Discrete
aUtilityOutOfLimits	Utility Out Of Limits	1057	Yes
aInternalCommFail	Internal Communication Failure	1062	Yes
aBattVoltsHigh	Battery Voltage High	1067	Yes
aCheckPowerSupply	Check Power Supply	1069	Yes
aCheckLogicSupply	Check Logic Power Supply	1070	Yes
aHeatsinkOverTemp	Heatsink Over Temperature	1072	Yes
aCheckHeatsinkSensor	Check Heatsink Temperature Sensor	1073	Yes
aRectifier125Overl	Rectifier Current Over 125%	1074	Yes
aInverterOffCommand	Inverter Off Command	1091	Yes

7.6 EMP (FC 04)



NOTE See for more information.

The optional EMP for the UPS can measure temperature and humidity. Because the device can be located outside the UPS, the reference is to auxiliary data. In addition, it contains two connections for monitoring the condition of auxiliary input contacts, such as a door switch. See [Table 12](#) for a list of EMP registers.

An exception code is returned if the EMP is not installed.

To read the temperature at the UPS, set the Modbus program to Unit ID 254 and register address 12028:

IP: <IP address of UPS>

Unit ID: 254

Starting Register: 12028

Number of registers: 2

Function Code: 04

Table 12. EMP Registers (FC 04)

Name	Register	Data Type	Bytes
Vendor Name	1032	STRING	64
Model Name	1064	STRING	64
Display Name	1096	STRING	64
Serial Number	1276	STRING	64
Device ID	1192	STRING	64
Auxiliary Input 1	10275	UINT	2
Auxiliary Input 2	10276	UINT	2

Table 12. EMP Registers (FC 04) (Continued)

Name	Register	Data Type	Bytes
Auxiliary Temperature	12028	FLOAT	4
Auxiliary Humidity	12030	FLOAT	4

7.7 Time or Date (FC 04)

Some UPS models support a time and/or date function. This format has a DATE data type and contains six bytes. Each byte represents the year, month, day, hour, minutes, or seconds (see for more information).

To read the UPS date and time, set the Modbus program to Unit ID 1 and register 12203:

IP: <IP address of UPS>

Unit ID: 1

Starting Register: 12203

Number of registers: 3

Function Code: 04

The UPS would return three registers containing hexadecimal data in the ym dh ms format (for example, May 17, 2007 at 10:45 and 20 seconds).

07 05	11 0A	2D 14
-------	-------	-------

Viewing each byte in decimal would yield the following data, which is viewable as the year (07), month (05), day (17), hour (10), minutes (45), and seconds (20):

07 05	17 10	45 20
-------	-------	-------

Viewing each byte as two-byte unsigned integers would yield the following data:

1797	4362	11540
------	------	-------

Viewing each byte as binary would yield the following data:

00000111 00000101	00010001 00001010	00101101 00010100
-------------------	-------------------	-------------------

Table 13. Time or Date Register (FC 04)

Parameter Name	Display Name	Register	Discrete	Units	Data Type	Bytes
mCurrentTime	Time	12203	No	No	DATE	6

Chapter 8 Specifications

Table 14. Technical Specifications

CPU	Freescale™ MPC8313
Memory	128 MB RAM, 1 GB NAND Flash
LAN Controller	Micrel® 3-port 10/100 Ethernet Switch
Network Connections	10/100BaseT RJ-45 Upstream port, plus 10/100BaseT RJ-45 Downstream port to optional daisy-chained Ethernet device USB 1.0 device port (used for initial network connection through a standard RNDIS driver)
UPS Protocol	Powerware Series UPS communication protocol
Network Protocols (not limited to)	SNMP v1 or v3 over UDP/IP Modbus TCP/IP HTTP/HTTPS BACnet/WS NTP SMTP DHCP TCP/IP (including IPv4 and IPv6)
Supported SNMP MIBs	Powerware UPS MIB RFC 1628 UPS MIB Eaton EMP MIB Eaton Alarms+Traps MIB Eaton Object Identifier (OID) assignments RFC 4133 Entity MIB RFC 4268 Entity State MIB RFC 4268 Entity State MIB Part 2
Operating Temperature	0–40°C (32–104°F)
Operating Humidity	10–80%, noncondensing
Power Input	7–28 Vdc unregulated (12 Vdc nominal)
Power Consumption	3.5 watts maximum
Size (L x W x H)	12 cm x 11.4 cm x 3.9 cm (4.7" x 4.5" x 1.5")
Weight	113 gm (4 oz)
EMC Statements	Class A: FCC Part 15 EU Standard: EN 55022:2006 Class A, EN 55024:1998+A1:2001:A2:2003

Chapter 9 Service and Support

If you have any questions or problems with the PXGX UPS Card, call your **Local Distributor** or the **Help Desk** at one of the following telephone numbers and ask for a PXGX UPS Card technical representative.

United States:	1-800-843-9433
Canada:	1-800-461-9166 ext 260
All other countries:	Call your local service representative

Please have the following information ready when you call the Help Desk:

- Model number
- Serial number
- Version number (if available)
- Date of failure or problem
- Symptoms of failure or problem
- Customer return address and contact information

If repair is required, you will be given a Returned Material Authorization (RMA) Number. This number must appear on the outside of the package and on the Bill Of Lading (if applicable). Use the original packaging or request packaging from the Help Desk or distributor. Units damaged in shipment as a result of improper packaging are not covered under warranty. A replacement or repair unit will be shipped, freight prepaid for all warranted units.



NOTE

For critical applications, immediate replacement may be available. Call the **Help Desk** for the dealer or distributor nearest you.

9.1 Two-Year Limited Warranty (US and Canada)

Power Xpert Gateway PXGX PDP and UPS Cards

WARRANTOR: The warrantor for the limited warranties set forth herein is Eaton (“Company”).

LIMITED WARRANTY: This limited warranty (this “Warranty”) applies only to the original End-user (the “End-user”) of any 3, 5 and 9 series Connectivity Devices (the “Product”) purchased on or after June 1, 2004, and cannot be transferred. This Warranty applies even in the event that the Product is initially sold by Company for resale to an End-user.

LIMITED WARRANTY PERIOD: The period covered by this Warranty for the Product installed [and currently located] in the fifty (50) United States, the District of Columbia, and Canada is twenty-four (24) months from the date of purchase.

WHAT THIS LIMITED WARRANTY COVERS: The warrantor warrants that the Product (the “Warranted Item”) is free from defects in material and workmanship. If, in the opinion of Company, a Warranted Item is defective and the defect is within the terms of this Warranty, Company’s sole obligation will be to repair or replace such defective Warranted Item (including by providing service, parts and labor, as applicable), at the option of Company.

PROCEDURES FOR REPAIR OR REPLACEMENT OF WARRANTED ITEMS: The Warranted Item will be repaired or replaced at a Company site or such other location as determined by Company.

If the Warranted Item is to be replaced by Company, and the End-user supplies a credit card number or purchase order for the value of the replacement Product, Company will use commercially reasonable business

efforts to ship (via standard ground shipment and at no cost to the End-user) the replacement Warranted Item to the End-user within one (1) business day after Company receives notice of the warranty claim. In such case, the End-user must return (at Company's expense) the defective Warranted Item to Company in the same packaging as the replacement Warranted Item received by the End-user or as otherwise instructed by Company. If Company does not receive the defective Warranted Item, Company will either charge the End-user's credit card, or send the End-User an invoice (which the End-user agrees to pay), for the value of the replacement Product.

If the Warranted Item is to be replaced by Company, but the End-user is unwilling or unable to supply a credit card number or purchase order for the value of the replacement Product, Company will use commercially reasonable business efforts to ship (via standard ground shipment and at no cost to the End-user) the replacement Warranted Item to the End-user within one (1) business day after Company receives the defective Product from the End-user.

In any case, Company will provide shipping instructions and will pay its designated carrier for all shipping charges for return of defective equipment and replacement of Warranted Items. Any returned Warranted Item or parts that are replaced may be new or reconditioned. All Warranted Items returned to Company and all parts replaced by Company shall become the property of Company.

WHAT THIS LIMITED WARRANTY DOES NOT COVER: This Warranty does not cover any defects or damages caused by: (a) failure to properly store the Product before installation; (b) shipping and delivery of the Product if shipping is FOB Factory; (c) neglect, accident, abuse, misuse, misapplication or incorrect installation; (d) repair or alteration not authorized in writing by Company personnel or performed by an authorized Company Customer Service Engineer or Agent; (e) improper testing, operation, maintenance, adjustment or modification of any kind not authorized in writing by Company personnel or performed by an authorized Company Customer Service Engineer or Agent; or (f) use of the Product under other than normal operating conditions or in a manner inconsistent with the Product's labels or instructions.

This Warranty is not valid if the Product's serial numbers have been removed or are illegible. Any Warranted Items repaired or replaced pursuant to this Warranty will be warranted for the remaining portion of the original Warranty subject to all the terms thereof.

Company shall not be responsible for any charges for testing, checking, removal or installation of Warranted Items.

COMPANY DOES NOT WARRANT EQUIPMENT NOT MANUFACTURED BY COMPANY. IF PERMITTED BY THE APPLICABLE MANUFACTURER, COMPANY SHALL PASS THROUGH SUCH MANUFACTURER'S WARRANTIES TO END-USER. COMPANY DOES NOT WARRANT SOFTWARE (IF APPLICABLE TO THE PRODUCT), INCLUDING SOFTWARE EMBEDDED IN PRODUCTS, THAT IS NOT CREATED BY COMPANY. WITHOUT LIMITING THE FOREGOING, COMPANY SPECIFICALLY DOES NOT WARRANT SOFTWARE (SUCH AS LINUX) THAT WAS CREATED USING AN "OPEN SOURCE" MODEL OR IS DISTRIBUTED PURSUANT TO AN OPEN SOURCE LICENSE.

COMPANY DOES NOT WARRANT SOFTWARE (IF APPLICABLE TO THE PRODUCT), INCLUDING SOFTWARE EMBEDDED IN PRODUCTS, THAT IS NOT CREATED BY COMPANY. WITHOUT LIMITING THE FOREGOING, COMPANY SPECIFICALLY DOES NOT WARRANT SOFTWARE (SUCH AS LINUX) THAT WAS CREATED USING AN "OPEN SOURCE" MODEL OR IS DISTRIBUTED PURSUANT TO AN OPEN SOURCE LICENSE.

THIS WARRANTY IS THE SOLE AND EXCLUSIVE WARRANTY OFFERED BY COMPANY WITH RESPECT TO THE PRODUCTS AND SERVICES AND, EXCEPT FOR SUCH FOREGOING WARRANTY COMPANY DISCLAIMS ALL OTHER WARRANTIES INCLUDING BUT NOT LIMITED TO ANY IMPLIED WARRANTIES OF MERCHANTABILITY, TITLE, NON-INFRINGEMENT, AND FITNESS FOR A PARTICULAR PURPOSE. CORRECTION OF NON-CONFORMITIES IN THE MANNER AND FOR THE PERIOD OF TIME PROVIDED ABOVE SHALL CONSTITUTE COMPANY'S SOLE LIABILITY AND END-USER'S EXCLUSIVE REMEDY FOR FAILURE OF COMPANY TO MEET ITS WARRANTY OBLIGATIONS, WHETHER CLAIMS OF THE END-USER ARE BASED IN CONTRACT, IN TORT (INCLUDING NEGLIGENCE OR STRICT LIABILITY), OR OTHERWISE.

LIMITATION OF LIABILITY: The remedies of the End-user set forth herein are exclusive and are the sole remedies for any failure of Company to comply with its obligations hereunder. In no event shall Company be liable in contract, in tort (including negligence or strict liability) or otherwise for damage to property or equipment other than the Products, including loss of profits or revenue, loss of use of Products, loss of data, cost of capital, claims of customers of the End-user or any special, indirect, incidental or consequential damages whatsoever. The total cumulative liability of Company hereunder whether the claims are based in contract (including indemnity), in tort (including negligence or strict liability) or otherwise, shall not exceed the price of the Product on which such liability is based.

Company shall not be responsible for failure to provide service or parts due to causes beyond Company's reasonable control.

END-USER'S OBLIGATIONS: In order to receive the benefits of this Warranty, the End-user must use the Product in a normal way; follow the Product's user's guide; and protect against further damage to the Product if there is a covered defect.

OTHER LIMITATIONS: Company's obligations under this Warranty are expressly conditioned upon receipt by Company of all payments due to it (including interest charges, if any). During such time as Company has not received payment of any amount due to it for the Product, in accordance with the contract terms under which the Product is sold, Company shall have no obligation under this Warranty. Also during such time, the period of this Warranty shall continue to run and the expiration of this Warranty shall not be extended upon payment of any overdue or unpaid amounts.

COSTS NOT RELATED TO WARRANTY: The End-User shall be invoiced for, and shall pay for, all services not expressly provided for by the terms of this Warranty, including without limitation, site calls involving an inspection that determines no corrective maintenance is required. Any costs for replacement equipment, installation, materials, freight charges, travel expenses or labor of Company representatives outside the terms of this Warranty will be borne by the End-User.

OBTAINING WARRANTY SERVICE: In the USA, call the Customer Reliability Center 7x24 at 800-356-5737. Outside of the USA, contact your local Eaton product sales or service representative, or call the Customer Reliability Center in the USA at 919-870-3149. For comments or questions about this Warranty, write to the Customer Quality Representative, 3301 Spring Forest Road, Raleigh, North Carolina 27616 USA.



164000972 1