

Power Management Connectivity & Monitoring

Contents

Power Management Connectivity & Monitoring

Introduction

- Designing a Power Monitoring and Control System for the Entire Power Distribution and Motor Control System **2.0-2**
- Copper and Fiber Optic Cable Wiring Guidelines for Ethernet Networks . . . **2.0-5**

Power Monitoring and Control for Power Distribution and Control Assemblies

- Medium Voltage Switchgear **2.1-1**
- Low Voltage Switchgear **2.1-3**
- Medium Voltage Motor Control **2.1-4**
- Low Voltage Motor Control **2.1-5**
- Low Voltage Commercial Power Distribution **2.1-6**
 - Low Voltage Switchgear **2.1-7**
 - Low Voltage Panelboard **2.1-8**

Connectivity and Software Products

- Power Xpert Ethernet Switches **2.2-1**
- Power Xpert Gateway 900 **2.2-2**
- Power Xpert Dashboard **2.2-9**
- Power Xpert Insight Software **2.2-14**
- Foreseer Services **2.2-20**

Power Management Systems & Products for Third-Party Integration

- MINTII RS-232 Converter **2.3-1**
- mMINT **2.3-2**
- PMINT **2.3-3**

Specifications

See Eaton's *Product Specification Guide*, available on CD or on the Web.

CSI Format	1995	2010
	Section 16901 & Section 16911	Section 26 27 13.11 & Section 26 09 13.13

Designing a Power Monitoring and Control System for the Entire Power Distribution and Motor Control System

Introduction

The main objective of system design is to produce a cost-effective, high-quality product. Several things stand in the way—unexpected equipment downtime, energy costs, reduced maintenance personnel and budgets, and limited capital. Downtime or power outage costs range from a few thousand to hundreds of thousands of dollars per hour in the lost production and related costs. In many facilities, the electrical energy consumption contributes significantly to overall cost of energy. Having the ability to monitor and control every aspect of the electrical use throughout the entire facility, provides the mechanism for turning off noncritical loads during times of high peak usage and during power outages to keep critical loads operational with limited electrical supply from a standby generator.

Consider These Facts

- Energy costs are growing at an average of 8 percent to 10 percent per year and any increase in power demand is dramatically more expensive (up to \$40/kW)
- Engineering and maintenance staffs are being asked to do more with fewer personnel
- Product quality is very dependent on the consistency of the power supply at a time when the utilities are being pushed to deliver more with no increase in generating capacity
- With the rise in energy costs and the shrinking energy availability, increasingly complex energy reporting and cost saving programs require elaborate monitoring and reporting systems

Power monitoring and control principles can be applied to the entire power distribution and control system. Ranging from medium voltage to low voltage equipment, solid-state devices equipped with communication interface modules make up the backbone of the power monitoring and control system network. The recommended approach to building the system is to use best-of-breed components that individually and together provide the best possible solution at the lowest cost.

What is Needed in this Environment?

By obtaining information and making it available in real time to the people who need to have it...provide energy consumption and performance information for the electrical distribution and control system effectively in a simple format that each person can understand and utilize. This information can be obtained from a power monitoring and control system (PMCS). The PMCS is a complete family of solid-state products including protective relays, meters and control relays designed to provide superior protection and metering from the utility incoming line down to a 15 A breaker or fractional horsepower motor. When connected together over a high-speed Ethernet network, it provides the necessary information to the right person in real time to ensure the plant and facility operates efficiently. It is also “open” to communicate with other communications systems used in a facility.

During the initial design of the power monitoring and control system, the designer will need to consider the type of information required for the right person in the facility.

Design Considerations

The following checklist provides a good set of guidelines to follow when designing a Power Monitoring and Control System (PMCS) for the electrical distribution and control system.

1. Consider solid-state overcurrent protection devices (OCPDs) such as: protection relays, circuit breaker trip units and overload relays, on all circuits greater than 100 A. This provides the foundation to add: remote I/O, shunt trip release, motor operator, remote racking device, and communications for remote monitoring, configuration and control of the OCPD.
2. Add Power Quality Metering (PQM) to monitor and record electrical information such as:
 - Voltage
 - Current
 - Power
 - Demand
 - Energy
 - Power factor
 - Frequency
 - THD
 - Alarms
 - Waveform capture

Critical or key points in the electrical distribution and control system such as:

 - Incoming main breakers on distribution equipment
 - Large feeders on distribution equipment 225 A and greater
 - Main breaker or Main Lug Only (MLO) panels
 - Main breaker on motor control centers
 - Starters with large loads such as 100 hp and above
 - Bus duct feeder runs
 - Large loads; 100 A bus plugs and above
3. Coordinate with other divisions (mechanical systems, control systems, network infrastructure) for making OCPD information accessible on the company network or control networks.
4. Take into consideration which personnel need access to certain levels of control of the OCPD or other communicating devices such as: meters, relays and communications gateways.
5. Plan for the installation and routing of necessary communication cables, conduits and trays to connect equipment together to form a network or to connect to an existing network.
6. Work closely with the customer or building owner to discuss the long-term ownership of the power monitoring system and the maintenance associated with it. Items to discuss are: firmware updates to all electronic equipment, long-term data storage of monitored trend data, and security passwords for key personnel to access the equipment.

Safety Considerations

Safety is a concern anytime maintenance personnel are required to be near or perform service on energized electrical equipment. Eaton has taken this concern very seriously and has designed a system to make safety the number one focus. The design goal of the system is to limit the interaction with energized electrical equipment to the absolute minimum. The biggest area of concern pertains to opening and closing switches and circuit breakers while equipment is energized.

Security Considerations

Every day, cyber-attacks against government and commercial computer networks number in the millions. According to U.S. Cyber Command, pentagon systems are probed 250,000 times per hour. Similar attacks are becoming more prevalent on other kinds of information-based smart networks as well, such as those that operate buildings and utility systems. Whether the objective is to steal intellectual property or halt operations, the tools and the techniques used for unauthorized network access are increasingly sophisticated.

Connectivity—why do we need to address cybersecurity for power monitoring and control systems (PMCS)?

There is increasing concern regarding cybersecurity across industries where companies are steadily integrating field devices into enterprise-wide information systems. This occurs in discrete manufacturing and process industrial environments, a wide range of general and specific purpose commercial buildings, and even utility networks. Traditionally, electrical systems were controlled through serial devices connected to computers via dedicated transceivers with proprietary protocols. In contrast, today's control systems are increasingly connected to larger enterprise networks, which can expose these systems to similar vulnerabilities that are typically found in computer systems.

The differences between information technology (IT) and networks can be summarized as follows:

- The main focus of the IT network is to ensure the confidentiality and the integrity of the data using rigorous access control and data encryption
- The main focus of the ICs network is safety, availability, and integrity of data
- Enterprise security protects the servers' data from attack
- Control system security protects the facility's ability to safely and securely operate, regardless of what may befall the rest of the network

Cybersecurity threat vectors are paths or tools that an entity can use to gain access to a device or a control network in order to deliver a malicious attack.

Potential threats include:

- External users accessing the network through the Internet misconfigured firewalls
- Unsecure wireless routers and wired modems
- Infected laptops located elsewhere that can access the network behind the firewall
- Infected USB keys and PLC logic programs
- Unsecure RS-232 serial links

The most common malicious attacks come in the following forms:

- **Virus**—a software program that spreads from one device to another, affecting operation
- **Trojan horse**—a malicious device program that hides inside other programs and provides access to that device
- **Worm**—a device program that spreads without user interaction and affects the stability and performance of the ICs network
- **Spyware**—a device program that changes the configuration of a device

Controlling access to the power monitoring system is an excellent step toward securing it. Many regulatory agencies and standards organizations now recommend/require Role-Based Access Control (RBAC) as part of any access control effort. To support this, the power monitoring system components have a robust set of tools to create the set of users and role-based permissions needed to comply with security policies in effect at your site. As a good rule of thumb, it is a good idea to have the customer review their policies and have a good understanding of the access control requirements for their site.

By default, most power monitoring systems are provided with two user types:

Admin: has access to all functions and can edit anything (admin role). The password for the admin account is also admin.

User: can view any information on the tabs, but can't access Settings or edit anything. The password is "user."

Before doing anything else, change the default account names and logins. Not only are these users not compliant with RBAC, keeping them is a security hazard. Keep in mind that this manual, along with the login names and passwords, is published on the Internet. Anyone with either physical access to the PXG or to your ICS network could know how to login as the admin user. You'll need to replace these accounts with RBAC compliant ones to meet the needs of your security policy. While the Admin user is useful for commissioning, it's a security risk to maintain a single account with all permissions.

Design Considerations for Interoperability with Open Systems

Eaton has chosen to use Ethernet communication networks both internal and external to the switchgear. The use of Ethernet technology has become more accepted and prevalent for industrial applications. Ethernet networks are faster and have become much more deterministic over the years.

The Eaton Power Xpert Gateway / Dashboard Server is typically installed inside the switchgear assembly to consolidate all of the device data into a single point of access.

The gateway function of this device provides a source of data to third-party systems e.g.: Building Management System (BMS) using common data protocols such as: BACnet/IP and Modbus TCP/IP. These protocols provide the means to request and receive metering and breaker status information for visualization, data trending and status within the BMS software graphics screens.

Eaton provides data reference tables for Modbus TCP/IP in the form of printed "register maps" that are available in PDF format on the Eaton website. These register maps will assist the BMS integrator personnel when building their data tables.

Alternatively, if the BMS integrator personnel choose to use the BACnet/IP data path, all that needs to be done is discover the entire device tree shown below as a new BACnet object. This method eliminates the need to manually create the device tables and simply drag and drop elements on the BMS graphic screens.

Network	Alarms	Onlines
Power Xpert Gateway		
Yoyodyne Propulsion Systems		
Network 2 (Ethernet)		
Main A Breaker - EDR-5000		
Main B Breaker - EDR-5000		
Main A Meter - PXM 6000		
Main B Meter - PXM 6000		
Tie Breaker - EDR-3000		
Tie Breaker Meter - PXM 2280		
Feeder 1A Breaker - EDR-3000		
Feeder 2A Breaker - EDR-3000		
Feeder 1B Breaker - EDR-3000		
Feeder 2B Breaker - EDR-3000		
Feeder 1A Meter - PXM 2280		
Feeder 2A Meter - PXM 2280		
Feeder 1B Meter - PXM 2280		
Feeder 2B Meter - PXM 2280		

Benefits of the Power Monitoring and Control System

Improved Energy Management

- Historical trending functions used to develop daily or seasonal load profiles
- Rapid reaction to utility load shedding requirements
- Accurate allocation of energy costs within a facility
- Reduce a peak demand
- Equalize loads to reduce potential downtime

Scheduled Maintenance Reduces Costs

- Preventive maintenance schedules can be developed from the database of real time mechanical and electrical equipment usage
- Alerts are provided to remind when preventive maintenance is required on monitored equipment
- Costs can be reduced through elimination of unnecessary maintenance dictated only by time instead of actual use
- Emergency maintenance problems are dramatically reduced

Early Warning Alerts to Potential Problems

- The operator is alerted to problems before they occur such as a breaker beginning to time out or a load about to be exceeded
- Problems can be corrected by shedding or equalizing loads while the cause is identified and corrected
- Isolation and correction of problems help ensure that a process or facility will not shut down

Instantaneous Troubleshooting Information

- Information on with breaker tripped, the cause and magnitude is available instantaneously
- Alarms which time stamping provide an indication of which event occurred first, second and so forth. This narrows the potential cause of a given trip
- Maintenance personnel are provided with information to identify the problem and have the system up and operating in minutes instead of hours

Increased Personnel Productivity

- Time-consuming data collection by dedicated personnel is unnecessary
- Maintenance personnel are free to perform actual maintenance functions to keep the equipment and facility operating
- Scheduled maintenance based on real time eliminates unnecessary maintenance
- Time-consuming troubleshooting to determine overload or fault source is eliminated

Copper Ethernet Cable Wiring Guidelines

The following information can be used as a guide when designing an Ethernet system using copper Ethernet cable.

- Cables should not be routed near equipment that generates strong electric or magnetic fields such as motors, drive controllers, arc welders and conduit
- Ethernet cable insulation has a voltage rating of 300 Vac. Use of barriers, cable trays or high voltage sheathing with STP Ethernet cable may be required in installations with cables carrying voltages greater than 300 Vac. This may also be necessary in order to comply with UL requirements. In installations where the cable cannot be physically separated from the power cables (where a physical barrier is not practical) fiber optic cable should be used
- When crossing power conductors with Ethernet cable, cross at right angles
- Shielded twisted pair (STP) Ethernet cable should be specified for use in high noise environments. Shielded shrouded connectors must be used and the shield must be connected at both ends of the wire. The mating plug must have a shielded shroud that is terminated to ground at both ends. Where there is a possibility of a difference in ground potential (common mode) voltages between the two terminated ends, fiber optic cable is recommended
- When using conduit or a metal cable tray, each section of the conduit or tray must be bonded to each adjacent section and the conduit or tray needs to be bonded to earth ground. Do not allow the shields to touch the conduit or metal tray at any point
- Only shielded (STP) Ethernet cables should be placed into metal conduit. Some UTP cables may not function properly when installed in conduit, as the metal conduit can affect the electrical properties of an unshielded cable. Consult the cable manufacturer when installing UTP cables in conduit
- As a general rule for noise protection, Ethernet Cable should maintain a minimum distance of 3 inches (8 cm) from electric power conductors for up to 100 V and 1 inch (3 cm) for each additional 100 V up to 400 V. STP cable is recommended
- For Ethernet cable run within conduit but near conductors with potentially noisy power conductors carrying currents of greater than 20 A or voltages greater than 400 V, maintain the following distances. STP cable is required
 - Conductors of less than 20 A = 3 inches
 - Conductors of 20 A or more and up to 100 kVA = 6 inches
 - Conductors greater than 100 kVA = 12 inches
- For Ethernet cable run near conductors with potentially noisy power conductors carrying currents of greater than 20 A or voltages greater than 400 V, maintain the following distances. STP cable is recommended
 - Conductors of less than 20 A = 6 inches
 - Conductors of 20 A or more and up to 100 kVA = 12 inches
 - Conductors greater than 100 kVA = 24 inches
- Route Ethernet cable at least 5 ft (1.5 m) from sources of rf/microwave radiation. STP cable is required
- Do not cascade more than four Ethernet repeaters (router, switch or hub) within a network segment
- Environmentally sealed connectors should be specified for cables used in outdoor installations
- Avoid pinching the cable when using cable ties
- Total distance between an Ethernet transmitter and receiver at the end points of the network should not exceed 328 ft (100 m)
- Total distance from a patch panel to a wall jack (using solid cable) shall not exceed 295 ft (90 m). Splices are not permitted
- Patch cords used as cross-connect jumpers in a patch panel should not exceed 20 ft (6 m)
- Patch cords from a wall jack to the work area PC (or device) shall not exceed 16 ft (5 m)
- Ethernet cable used in harsh environments must be selected to withstand the following conditions: vibration, air born contaminants, chemicals, temperature, electromagnetic interference, combustible atmospheres and local regulatory standards such as UL and NEMA
- Ethernet connectors used in harsh environments must be robust enough to withstand vibration, multiple connection cycles, temperature changes, and provide a proper seal to protect against moisture, dust/dirt and chemical attack
- Different cable media support different bandwidth capabilities. When installing cable in a network, care should be taken to install the cable that will fill current network loading requirements and future expansion needs. In general, fiber optic cable can support the greatest bandwidth (upward of 25,000 gigabits) and UTP has the lowest. CAT5e cabling is designed to operate a bit rates up to 1000 Mb and CAT6 cable up to 2000 Mb
- Operating your cable at maximum speed reduces the distance between network segments. Check with your cable supplier for specifications regarding segment distance vs. speed
- Cable with 5% impedance mismatch or return loss of 27 to 32 dB is recommended. Ethernet cable impedance can vary by as much as 15% (85 to 115 ohms). Average Ethernet cable with 15% impedance variation can have up to 10 dB additional return loss. This discontinuity is referred to as return loss, since it causes some of the signal to be reflected back down the cable instead of propagating forward. It is measured in decibels or ratio of transmitted versus reflected signal

Fiber Optic Technology

The use of fiber optics in telecommunications and wide area networking has been common for many years, but more recently fiber optics have become increasingly prevalent in industrial data communications systems as well. High data rate capabilities, noise rejection and electrical isolation are just a few of the important characteristics that make fiber optic technology ideal for use in industrial and commercial systems.

Although often used for point-to-point connections, fiber optic links are being used to extend the distance limitations of RS-232, RS-422/485 and Ethernet systems while ensuring high data rates and minimizing electrical interference.

Conventional electrical data signals are converted into a modulated light beam, introduced into the fiber and transported via a very small diameter glass or plastic fiber to a receiver that converts the light back into electrical signals.

Optical fibers allow data signals to propagate through them by ensuring that the light signal enters the fiber at an angle greater than the critical angle of the interface between two types of glass. Optical fiber is actually made up of three parts. The center core is composed of very pure glass. Core dimensions are usually in the range of 50–125 μm for multi-mode cables and 8–9 μm for single-mode cables. The surrounding glass, called cladding, is a slightly less pure glass. The diameter of the core and cladding together is in the range of 125–440 μm .

Surrounding the cladding is a protective layer of flexible silicone called the sheath.

Fiber Optic Cable Wiring Guidelines

The following information can be used as a guide when designing an Ethernet system using fiber optic Ethernet cable:

- Select a fiber cable that is suited for the application, e.g., outdoor, aerial, duct, intra-building, risers, general building and plenum applications
- Fiber optic cable is useful in applications where the environment is combustible, electrically noisy, the cable must be bundles with high voltage wires or where common mode voltages may exist between the earth ground points of the terminating connectors
- Fiber optic cable is available in various operating temperature ranges. Care should be taken to match the temperature rating of the fiber to the environment it will be exposed to. The temperature specification for fiber may be narrower than copper cable. Consult the cable manufacturer for temperature specifications of your cable type
- Sealed fiber connectors are available for use in harsh environments to prevent contamination from entering the connector and fiber. The type of seal required will be application dependant and can vary from dust- and moisture-proof to water-tight
- Mixing fiber cable types is not permitted. The same core dimensions and mode must be used within cable segments
- Care should be taken when purchasing connectors to include strain relief, which reduces mechanical strain (vibration) within the cable, as well as the connector. Strain relief also provides support to the cable to ensure proper bend radius at the connector
- Single-mode fiber is used for long distance transmission of up to 120 km. Distance may vary depending on speed and type of converter used
- Multi-mode graded-index fiber cable is used for communication over shorter distances of up to 2 km
- Fiber cable is composed of glass and is not well suited for applications requiring tight bend radiuses. Cable radius dimensions vary per manufacturer. If the manufacturer does not provide a bend radius, a typical rule of thumb is a radius not less than 15x the cable diameter
- Fiber cable to connector terminations can be performed in the field using special equipment. This method is not recommended
 - Tier One testing is recommended when diagnosing system irregularities and should be performed in all new installations
 - Tier Two testing is recommended to certify that a system complies with standards set forth by the owner/installer

Medium Voltage Switchgear

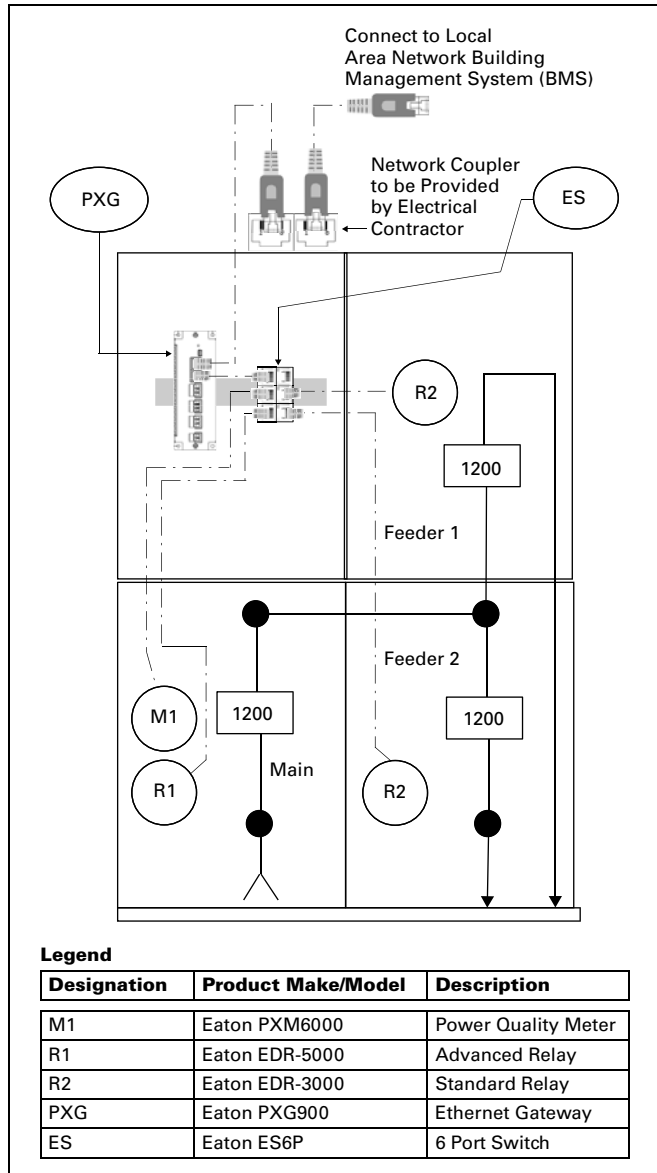

Figure 2.1-1. Two Section Medium Voltage Lineup

General Description

Device Selection

The devices shown in **Figure 2.1-1** have been chosen to provide the best feature/benefit to the end user. Typically the specifying consulting engineer or end user will have device preference; however, for the purpose of illustration, all Eaton devices have been selected. If there are no significant differences between the switchgear manufacturer's devices and those of a recommended third party, there are distinct advantages to allow the switchgear manufacturer to provide them. This allows the switchgear manufacturer to test to internal standards and minimize variation to aid in providing a high-quality and cost-effective product to the customer.

Protective Relay Selection

Eaton's medium voltage switchgear is supplied with both standard and advanced protective relays and meters. Depending upon the level of functionality required at each point in the switchgear, Eaton offers a choice in device selection.

Protection Functions

All of Eaton's E-Series protective relays are fully equipped with a standard set of protection functions and additional optional features.

The EDR-3000 is Eaton's standard protective relay typically selected for feeder protection. This relay monitors phase and ground current. The EDR-5000 is Eaton's advanced protective relay typically selected for main breakers. This relay monitors the line side voltage and bus voltage, as well as bus current. This provides the needed level of protection for the primary switchgear bus.

Features

Depending upon the specific requirements for local access to metering information at the switchgear, using the protective relay for metering as opposed to adding an additional set of current transformers and meters, may be acceptable.

Table 2.1-1. Metering Feature Comparison

Description	EDR-3000	EDR-5000
Metering and Monitoring Features		
Current (pos., neg. and zero seq.)	■	■
Current unbalance % (I2/I1)	■	■
Differential current	—	—
Voltage (L-L, L-N, pos., neg. and zero seq.)	—	■
Voltage unbalance % (V2/V1)	—	■
Phase angles	■	■
Volt-amps, watts, volt-amps reactive	—	■
kWh (forward, reverse and net)	—	■
kVAh (lead, lag and net)	—	■
Power factor	—	■
Frequency	—	■
Volts/Hz	—	—
2nd harmonic current % (H2/fund.)	—	—
3rd harmonic voltage	—	—
THD current (% and magnitude)	■	■
THD voltage (% and magnitude)	—	■
Minimum/maximum recording	■	■
Sync values	—	■
Temperature with remote URTD module	—	—
Trip circuit monitoring	■	■
Breaker wear and general counters	■	■
CT supervision	■	■
VT supervision	—	■
Waveform recorder (7200 cycles total storage)	■	■
Fault recorder (20 events)	■	■
Sequence of events recorder (300 events)	■	■
Trend recorder	■	■
Motor history, start trending, thermal capacity	—	—
Generator hours of operation	—	—
Programmable logic equations (up to 80)	■	■

Medium Voltage Switchgear

2

Model Comparison Guide—Protective Functions

EDR-3000	EDR-5000	
Protection Functions 46 — Current unbalance elements 50BF — Breaker failure 50P — Phase instantaneous overcurrent elements 50R — Calculated ground or neutral instantaneous overcurrent elements 50X — Measured ground or neutral instantaneous overcurrent elements 51P — Phase overcurrent protection per time-current curve elements 51R — Calculated ground fault protection per time-current curve elements 51X — Measured ground or neutral fault protection per time-current curve elements CLPU — Cold load pickup SOTF — Switch on to fault CTS — Current transformer supervision 74TCM — Trip coil monitor (option) ZI — Zone selective interlocking (option)	The EDR-5000 has all of the same protection functions as the EDR-3000 with additional features.	
	Enhanced protection functions 27A/M — Auxiliary and main three-phase undervoltage elements 47 — Voltage unbalance elements 55A/D — Apparent and displacement power factor elements 59A/M — Auxiliary and main three-phase overvoltage elements 59N — Ground fault overvoltage elements 67P — Directional overcurrent elements 67X — Calculated directional overcurrent elements 78V — Vector surge element 81U/O/R — Under and over and rate of change frequency elements LOP — Loss of potential 25 — Sync check 32 — Forward and reverse watts elements 32V — Forward and reverse VARs elements	51V — Voltage restraint elements 79 — Auto-reclosing 27T — Low voltage ride-through (LVRT) 27Q — Reactive power and undervoltage

Typical One-Line Example—ANSI Protective Elements Guide

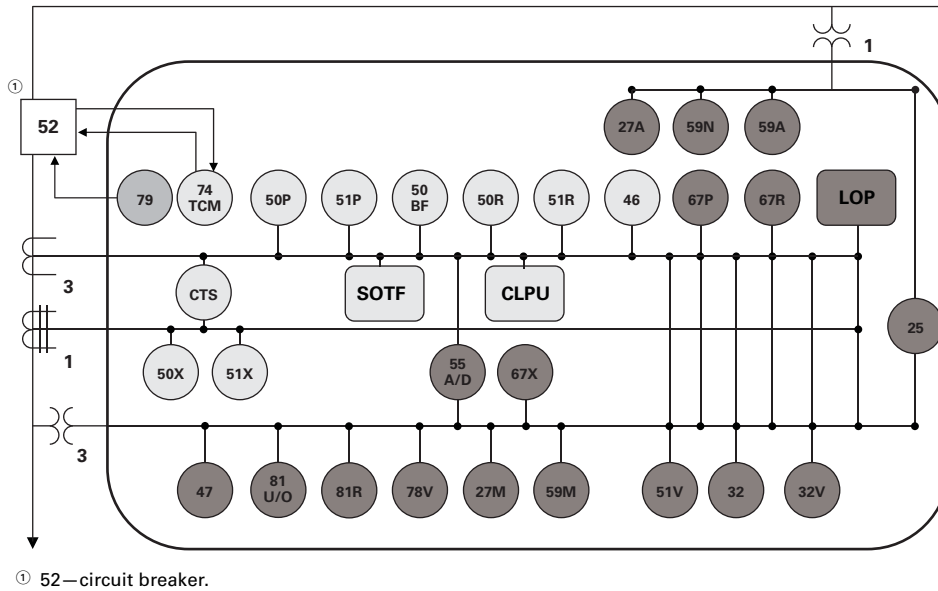

Protective Elements Key
 ◻ = Elements available on EDR-3000 and EDR-5000
 ◼ = Elements available on EDR-5000
 See **Page 1** for metering features.

Figure 2.1-2. Protection Feature Comparison

Low Voltage Switchgear

TO COME

General Description

COPY TO COME.

Medium Voltage Motor Control

2

TO COME

General Description

COPY TO COME.

Low Voltage Motor Control

TO COME

General Description

COPY TO COME.

**Low Voltage Commercial
Power Distribution****2***TO COME***General Description**

COPY TO COME.

Low Voltage Switchboard

TO COME

General Description

COPY TO COME.

Low Voltage Panelboard**2***TO COME***General Description**

COPY TO COME.

Power Xpert Ethernet Switches



Convenient Network Expansion

General Description

Eaton's Power Xpert Ethernet switches are ideal for extending Ethernet networks via CAT5 wiring or fiber in harsh, industrial environments. Built with high-grade components and constructed using special thermal techniques, PXE switches can withstand the unpredictable conditions of such environments.

Features

- Simultaneous, full-duplex, high-speed communication on all ports—no network performance bottlenecks
- Hardened for factory floor—ideal for both industrial or data center applications
- Unmanaged, plug-and-play implementation—no software or additional hardware required for configuration
- Seamlessly integrates into Eaton's Power Xpert Architecture—quality and reliability of Eaton guaranteed
- Mounting options include stand-alone panel-mounting, DIN rail mounting, or 19-inch standard rack mounting

PXE 6-Port Switch—10/100 Mb with Optional 100 Mb Fiber

This compact switch provides six Ethernet ports, with flexible configurations. The base models have one of three options:

- Two 100 Mb fiber and four 10/100 copper ports
- One fiber and five copper ports
- Six copper ports

PXE 4-Port Switch—10/100 Mb

For smaller applications requiring fewer connection points and no fiber, the 4-port Power Xpert Ethernet switch is a versatile option. It provides edge access Ethernet ports in a convenient and compact package.

Technical Data and Specifications

Table 2.2-1. Power Xpert Ethernet Switches

Description	Catalog Number
4 port Ethernet switch—copper only	PXES4P24V
6 port Ethernet switch—copper only	PXES6P24V
6 port Ethernet switch—5 copper/1 fiber (ST connector)	PXES6P24V1ST
6 port Ethernet switch—4 copper/2 fiber (ST connector)	PXES6P24V2ST

Table 2.2-2. Accessories

Description	Catalog Number
Power supply (preferred)—100–240 Vac input DIN rail mount with screw—24 Vdc output terminals	ELC-PS02
Power supply (alternate)—120 Vac input Wall plug-in type with 6 ft. cord—12 Vdc output	PXESPS12V
DIN rail mounting bracket	PXESDINRL
19-inch rack mount tray	PXESTRAY

Table 2.2-3. Operating Environment

Description	Specifications
Ambient temperature ratings	–25 ° to 60 °C long-term per independent agency tests (UL), or –40 ° to 85 °C short-term per IEC type tests
Storage temperature	–40 ° to 185 °F (–40 °C to 85 °C)
Cold start	to –20 °C
Ambient relative humidity	5%–95% (noncondensing)
Altitude	–200 to 50,000 ft (–60 to 15,000 m)
MTBF	> 15 years

Table 2.2-4. Network Standards

Description
Ethernet IEEE 802.3, IEEE 802.3u; IEEE 802.1p, 100Base-TX, 10Base-T, 100Base-FX

Table 2.2-5. Agency Approvals and Standards Compliance

Description
UL listed (UL60950), cUL, CE, emissions meet FCC Part 15, Class A

Table 2.2-6. Power Consumption

Description
7.0 watts typical—9 watts maximum

Table 2.2-7. Packaging

Description	Specifications
Enclosure	Robust sheet metal (steel)
Dimensions of PXES4P series	3.50 in H x 3.00 in W x 1.00 in D (8.9 cm x 7.6 cm x 2.5 cm)
Weight of PXES4P series	8.6 oz. (243g)
Dimensions of PXES6P series	3.60 in H x 3.00 in W x 1.70 in D (9.2 cm x 7.6 cm x 4.3 cm)
Weight of PXES6P series	13 oz. (370g)
Cooling method	Case used as a heat sink

Table 2.2-8. Mounting

Description	Specifications
Metal panel mounting clips	Included
DIN rail mounting	Optional
19-inch rack mount	Optional

Note: These specifications are subject to change without notice and represent the maximum capabilities of the product with all options installed. This is not a complete feature list. Features and functionality may vary depending on selected options and product model. Please refer to the technical data sheet and user manual for detailed specifications. Please see www.eaton.com/powerxpert for latest information.

Power Xpert Gateway 900

2

Power Xpert Gateway 900

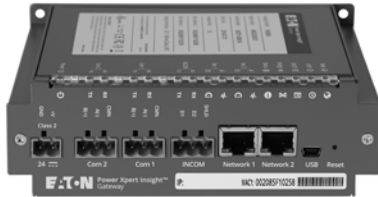

Delivers real-time, Web-enabled monitoring of electrical distribution and control equipment

General Description

The Power Xpert Gateway 900 (PXG 900) has been designed to be installed in electrical assemblies or systems—low and medium voltage switchgear, switchboards, panelboards, transfer switches, and motor control centers to acquire and consolidate data available from components such as trip units, meters, relays, drives, and I/O.

Product Overview

- Open communication architecture
 - Connects to both Eaton and third-party electrical equipment; communicates to INCOME, Modbus[®] TCP, and Modbus RTU devices
 - Modbus TCP and BACnet/IP support facilitates integration with third-party monitoring solutions
 - Ethernet/Web-based support uses your existing network infrastructure, reducing costs
- Flexible and expandable solutions
 - Stand-alone or small systems benefit from comprehensive, on-board Web pages; no additional programming or software is necessary for virtually out-of-the-box, plug-and-play functionality
 - Larger systems, such as campus installations or power systems with remote locations can view multiple PXGs via Power Xpert Insight[®] or a third-party monitoring system
 - Existing equipment can be connected to the PXG to reap the benefits of Power Xpert Architecture at minimal cost, without the need to upgrade

Information at a glance

- Private Network mode on the Net 2 port will allow for the ability to establish a private subnet to attach Modbus TCP communication devices
- Using a standard Web browser, view the PXG's Web interfaces that include a Network tab, Alarms tab, individual device detail pop-outs, and One Line graphics tab
- Comprehensive, well-organized device Web pages present measured parameters such as current, voltage, power, energy, frequency, power factor, and voltage THD, just to name a few
- Combine with Power Xpert Insight for viewing multiple gateways and other power system equipment for more extensive energy monitoring and capacity analysis

Monitoring Power and Energy in a Networked World

Through standard on-board Web pages, Power Xpert Insight, or third-party software, Eaton's Power Xpert Gateway (PXG) 900 allows you to closely monitor the performance of your power and energy efficiency with easily accessed, real-time, Web-enabled data. Eaton's PXG 900 provides a central point to connect devices to an Ethernet network. The gateway may be used as a standalone device to view one system or location, or it can be easily integrated into a large, multi-location system.

The PXG is our configurable data acquisition solution for facility equipment like switchgear, switchboards, motor control centers, etc. Power and energy data from the downstream devices are time stamped and stored in non-volatile memory. This interval data can be stored or updated to a destination of the user's choice through CSV. Data can also be accessed through any Web browser directly on the PXG. Users can move data into Power Xpert Insight v. 3.2 or higher, BMS, BAS, building dashboards, custom software applications, or virtually any Web interface.

Features and Benefits

Rugged, Industrial Design

- Designed specifically for industrial environments, the PXG has a compact design that only requires convection cooling
- Stringent EMI design requirements ensure that the PXG will function in the most difficult EMI situations to deliver high reliability
- Mounting options are provided for panel mounting or DIN rail, allowing for installation flexibility

Smart Configuration and User Interface

- As an out-of-the-box, plug-and-play device, there is no additional software required to configure and view downstream devices
- All configuration menus are straightforward and easy to follow
- Upon configuring the PXG and associated devices, the data will automatically appear in the Web UI when you point your browser to the IP address of the PXG

Three operational modes

The Power Xpert Gateway can operate in three modes, simultaneously if required, providing flexibility for varying protocols, devices, and systems. For further details of each operational mode, see user manual. For a graphical representation of each mode, see **Figure 2.2-1**.

1. INCOM Pass-Through mode allows data from INCOM serial devices to flow directly through the gateway to be viewed in PowerNet[™] software for logging and consolidation with other connected devices.
 - Expansion of an existing PowerNet system with additional equipment can be easily achieved by adding a PXG 900 to the system to bring the INCOM communicating devices online in INCOM pass-through mode.

Note: INCOM serial communication can either be cached or EMINT/pass-through, not both at the same time.

Power Xpert Gateway 900

2. The Modbus RTU-Modbus TCP Pass-Through mode allows information from Modbus serial devices to pass directly through the gateway to be viewed by a (or multiple) Modbus TCP monitoring software, i.e., an existing Building Management System.
 - The PXG allows users to do simple protocol translation, with minimal configuration in the PXG for those applications where they need Modbus TCP to bring devices into their existing system.
 - The flexibility of the PXG for simple Modbus protocol translation in conjunction with other mode's makes the PXG more than a simple Modbus protocol translator.
3. Cache mode allows data from INCOM serial devices and Modbus RTU and TCP devices into the gateway, creating real-time viewing status through a Web browser as well as logging for historical reference and trending. Cached data from the connected devices can be shared with other client software similar to pass through.
 - The PXG in Cache mode serves as an acquisition tool and provides the ability for users to view their devices on the ports connected to the PXG through a Web browser. This allows users to bring power infrastructure equipment online to monitor operation and record power and energy usage.

Secure Cyber Communication

Controlling access to the PXG 900 is a vital component in any effort to secure it. Many regulatory agencies and standards organizations now recommend/require Role-Based Access Control (RBAC) as part of any access control effort. To support this, the PXG 900 has a robust set of tools you can use to create the set of users and role-based permissions you need to comply with security policies in effect at your site.

- **Password protection**

Role-Based Access Control (RBAC) as part of any access control effort. To support this, the PXG 900 has a robust set of tools you can use to create the set of users and role-based permissions you need to comply with security policies in effect at your site

- **Secure Web browsing**

SSL Encryption option ensures that information and passwords exchanged with the PXG's Web server cannot be intercepted on the LAN

- **Access control / trusted host list**
Provides an additional method of security by limiting access to the communication ports by authorized trusted hosts' IP addresses

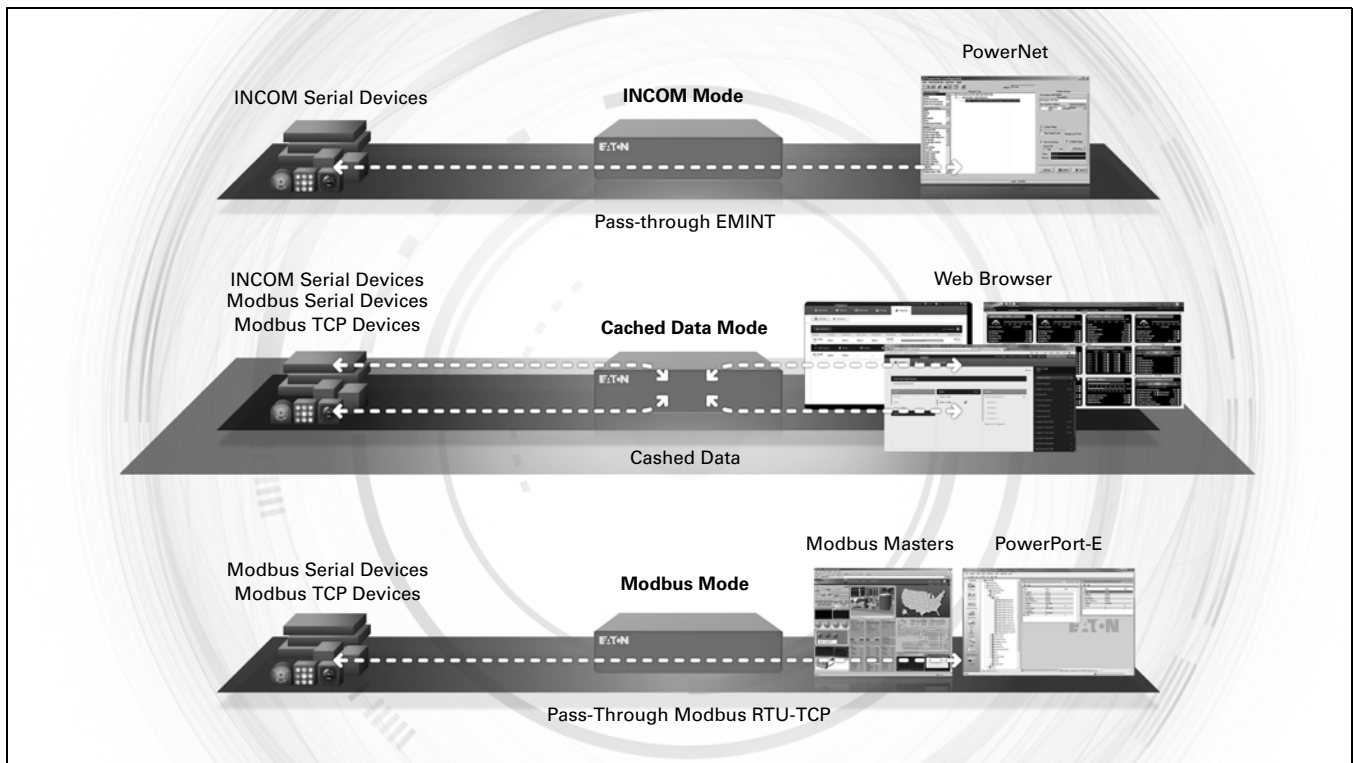

Figure 2.2-1. Three Operational Modes

Power Xpert Gateway 900

Time Synchronization

The PXG supports synchronization of clocks on INCOM devices that support the set time and date command. Additionally, the PXG can be combined with a network time server for accurate time stamping via NTP.

Real-time trending and viewing

The PXG 900 allows the user to enable pre-selected parameters to be trended for each supported device. This feature is user-selectable on the device configuration page. A trend symbol is displayed next to the trended parameter on the device page. Selecting the trend symbol will generate a real-time graph via the Web UI for that parameter and can be viewed for the past 24 hours, 7 days, 30 days or all past history.

Trend and alarm logging and analysis

The PXG 900 stores both historical data and alarms that can be downloaded into a comma separated value (CSV) file format. Using Excel® will allow you to perform analysis to discover potential system issues or proactively perform maintenance.

Waveforms capture and downloads

The PXG 900 supports waveform acquisition for INCOM supported devices capable of generating waveforms. This feature is user-selectable on the device configuration page. The waveform files are converted and stored as a COMTRADE file format in the PXG 900. The files can then be downloaded and viewed using a standard COMTRADE waveform viewer of your choice.

Table 2.2-1. Summary of PXG 900 features

Features	PXG 900
Protocols supported on downstream devices: INCOM, Modbus TCP, and Modbus RTU	Yes
Number of downstream communication ports	3
Number of downstream protocols supported simultaneously	2
USB port for configuration	Yes
Two RJ-45 Ethernet ports—10/100/1000Base-T	Yes
Modbus TCP/IP protocol supported	Yes
BACnet/IP protocol supported	Yes
INCOM date and time settings supported	Yes
Network tab, alarm tab, one line tab, device and alarm detail sidebar, and pop-out	Yes
Device waveform access and storage—COMTRADE file format	Yes
Set user-defined alarms	Yes
Real-time trending	Yes
Trend graphs displayed in Web browser	Yes
Alarm notification via the Web interface	Yes
Alarm logs—csv file format, downloadable to Excel	Yes
Trend logs—csv file format, downloadable to Excel	Yes
Email notification on alarms and daily updates if requested	Yes
Secure Ethernet communication—SSL encryption	Yes
Secure communication ports via access control/trusted host list	Yes
IPv4 support	Yes
Save and restore configuration settings	Yes
Audit logs	Yes

Note: The Eaton Power Xpert Gateway 900 includes the Power Xpert Gateway Module, USB A to Mini-B USB cable, and DIN rail adapter with mounting screws.

Power Xpert Insight Gateway user interface

Network Tab

Default log-in screen that provides general configuration of the gateway, serial communication ports, and devices. The Network tab provides a simple view of the serial devices and their current status of operation by color changes and symbols. Additional detail and functionality is accessible from the Network tab sidebar for all communicating devices.

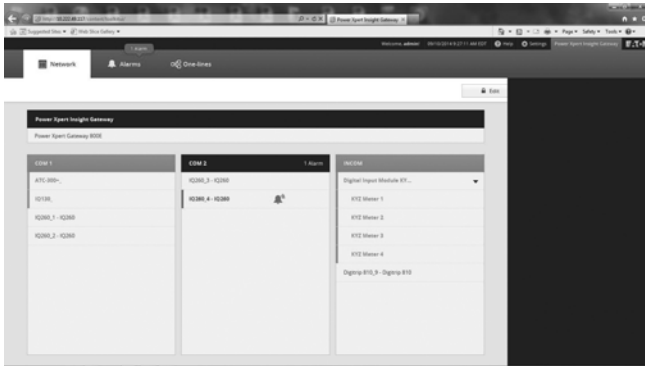

Alarms Tab

Provides a single screen that provides details on all alarms associated with the device communicating in cache mode through the gateway. Alarms can be reviewed and acknowledged, as well as sorted and filtered based on status. Additional information regarding the alarm can be found by selecting the alarm and specifics on the alarm will be displayed in the sidebar.

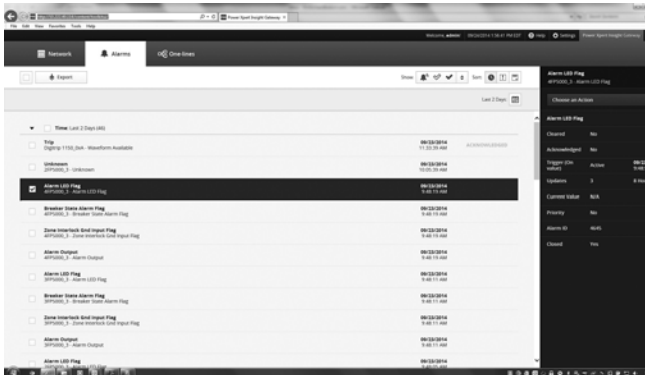

One-Lines Tab

Allows users the ability to create a graphical representation of a one-line diagram based on the user's desired representation. Through the device tree, a user can select devices and group them in locations and generate a multiple level one-line representing the devices connected to the gateway. The one-line graphic will provide device status graphically, and additional detail can be found on the device and its supported channels in the sidebar of a selected device on the one-line or device tree.



Device Details and Trend Viewer

Selected devices on the Network tab and One-Lines tab provide a device sidebar. From that sidebar, a user can get additional detail about the device and its monitored channels, by selecting the choose an action menu on the sidebar. This will allow users to see the device details pop-out as well as gain access to historical trend data and other available information regarding the selected device.

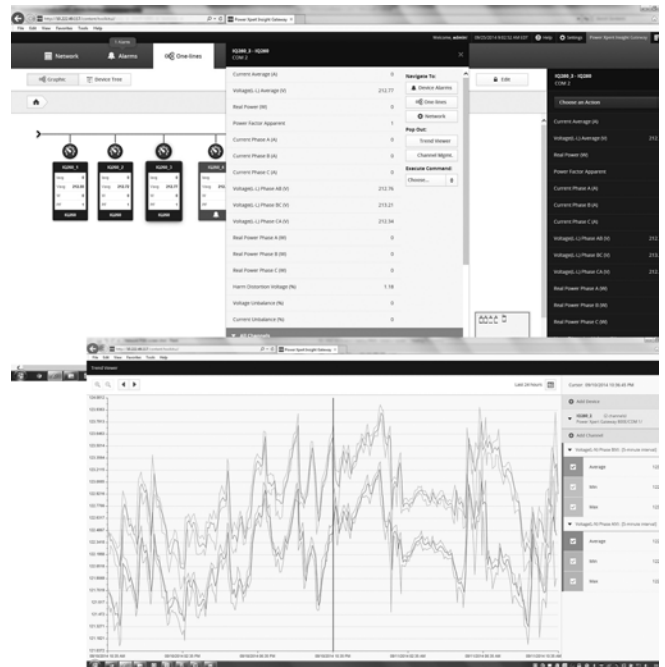

2

Power Xpert Gateway 900

2

User-Defined Alarms

The PXG 900 supports the setting of user-defined alarms on an individual device and channel basis. This feature is set for enabled channels via the Setting button in the header under the alarms setting tab. An example of a user-defined alarm would be a low and high limit on the phase A current channel for a device. The alarm limit values and the alarm names can be chosen by the user.

Email Notification

A user has the ability to customize and direct email notifications to up to 10 users in their organization. Select from alarm notifications, trend log, alarm log, and daily emails. This function provides yet one more way to effectively and proactively manage your monitored system.

Save and Restore Configuration Settings

The PXG provides the ability to save the PXG device and network configuration settings to an XML file format. It can be used to restore settings to any PXG to facilitate configuration of similar systems.

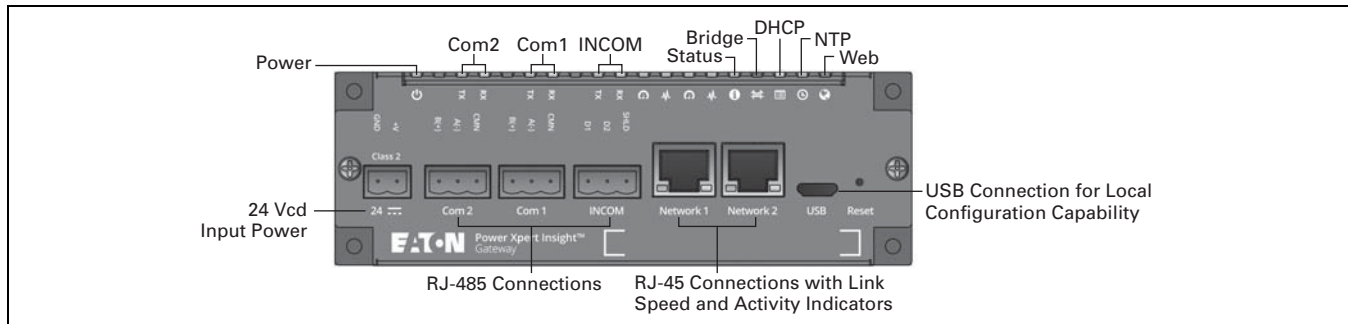

Figure 2.2-2. Power Xpert Gateway 900

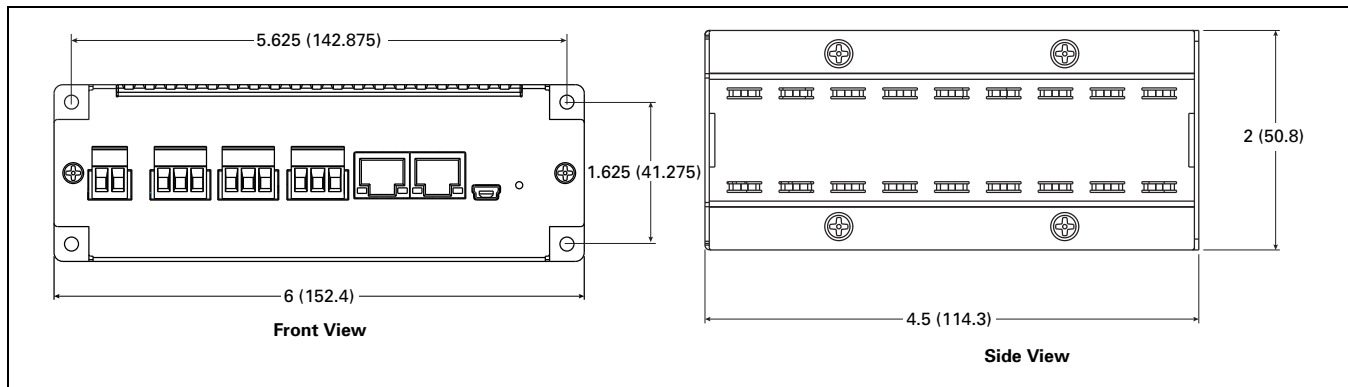

Figure 2.2-3. Power Xpert Gateway 900 with Standard Panel Mounting

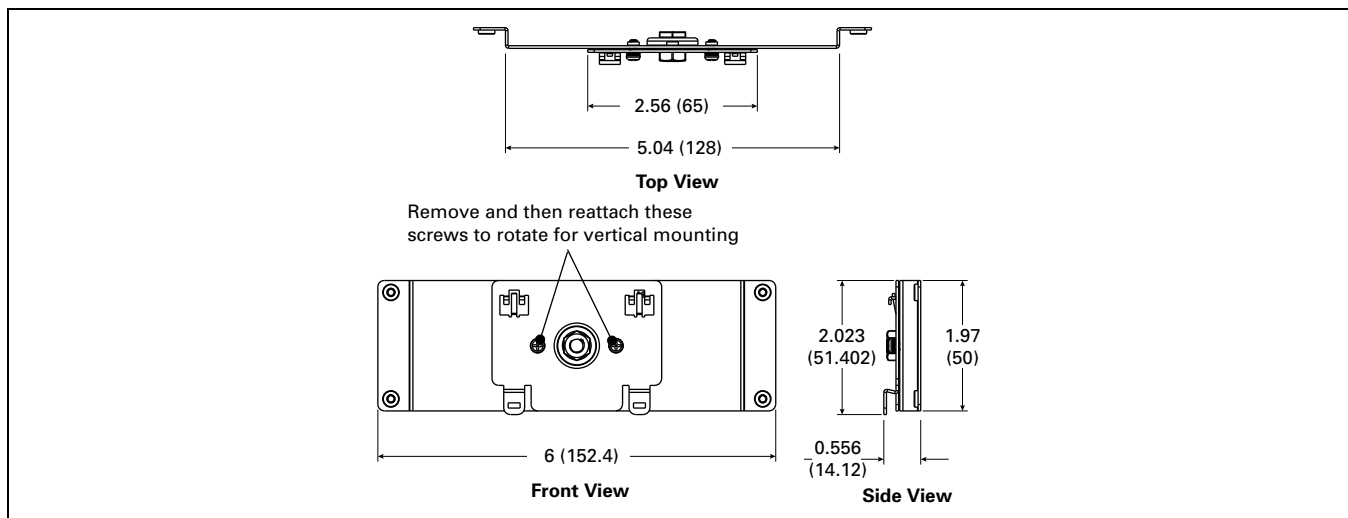

Figure 2.2-4. Power Xpert Gateway 900 with DIN Rail Mounting (Brackets Included)

Power Xpert Gateway 900

**Power Xpert Gateway
Enclosed Version**



Enclosed Version

- Cost-effective solution to add communications to new or existing equipment that has no physical space to install the PXG in the equipment structure
- NEMA 12 enclosure rating
- Prewired with a PSG60N24RP power supply and terminal blocks for ease of wiring of incoming power and connected devices

**PXG Daisy Chain Application
in Bridge Mode**

The PXG allows for units to be connected together through two RJ-45 10/100/1000 connectors on the front of the PXG series of products. Default is bridged mode for the daisy chain application. This arrangement is a pass-through of Ethernet communications, allowing a single network drop to connect up to five Ethernet communicating devices. The maximum length of a copper cable run should not exceed 295 ft (90 m) total.

Note: In this configuration, if any of the PXG units go offline or lose power, the communication to the downstream Ethernet devices will lose connection to the LAN.

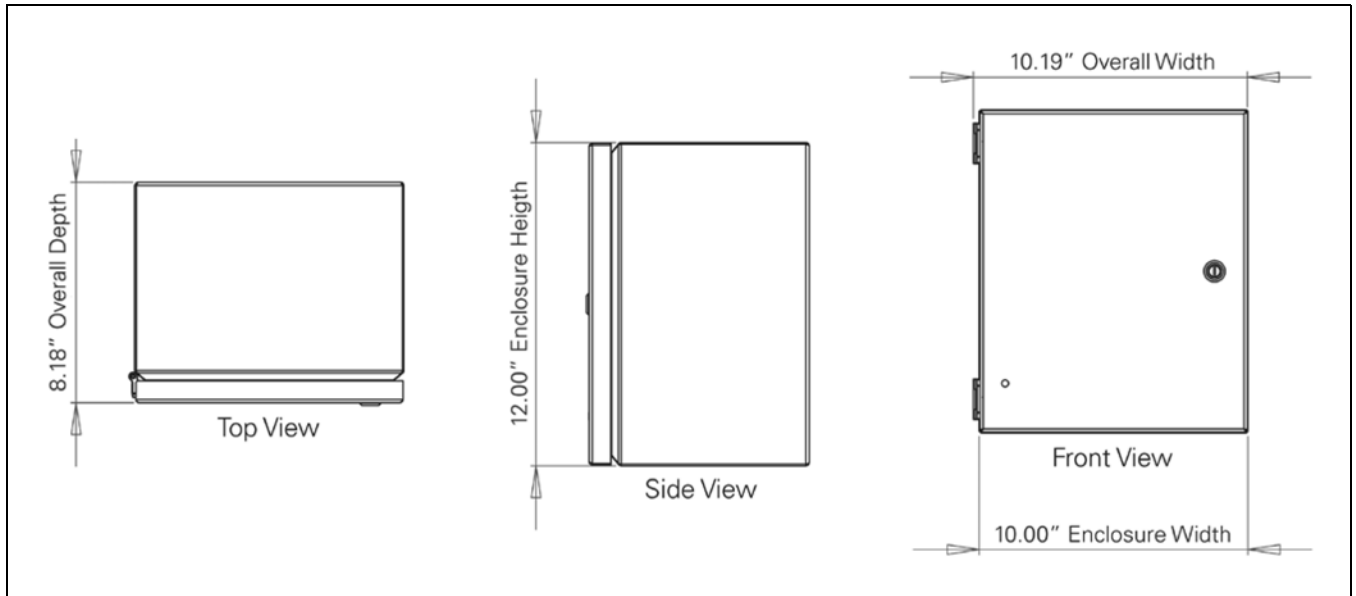

Figure 2.2-5. Power Xpert Gateway Enclosure Dimensions

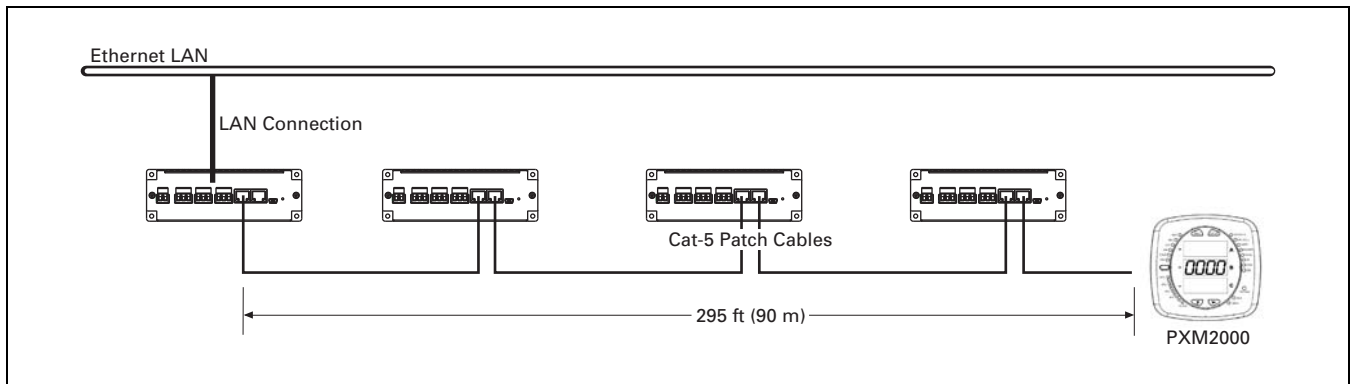

Figure 2.2-6. PXG Daisy Chain Application

Power Xpert Gateway 900

Technical Specifications

Table 2.2-2. PXG Part Numbers

Description	Eaton Style Number	Eaton Catalog Number
Power Xpert Gateway 900	66D2325G01	PXG900
Power supply—24 Vdc	PSG60N24RP-A1	PSG60N24RP
Enclosed Power Xpert Gateway		PXG900-2A

2

Memory

- Flash: 2 GB
- RAM: 1 GB

Communication Ports

- Network ports: Two 10/100/1000Base-T RJ-45 connectors
- Serial ports
 - Two RS-485 ports for connection to Modbus RTU devices
 - One dedicated RS-485 port for INCOM devices
- Configuration port: One USB port

Network Protocols Supported

- Modbus TCP/IP: Supports data access from Modbus TCP clients
- Web server: Supports data access from Web browsers (HTTP and HTTPS)
- DHCP: Supports automatic IP address assignments, if enabled
- NTP: Supports time synchronization via a network time server for PXG synchronization
- SMTP: Supports mail server for email notification
- BACnet/IP: Supports data access from BACnet clients

Serial Protocols Supported

- INCOM
- Modbus RTU

Web Browsers Recommended

- Internet Explorer versions 10 and 11
- Google Chrome

Power Input

- Input voltage, nominal: 24 Vdc; 0.3 A minimum
- Input voltage range: $\pm 10\%$ nominal

Power Consumption

- 8 W maximum

Operating Temperature

- +32 to +140 °F (0 to +60 °C)

Ambient Storage Temperature

- -40 to +185 °F (-40 to +85 °C)

Relative Humidity

- 5 to 95% noncondensing at 122 °F (50 °C)

Size (H x D x L) in Inches

- 2.00 x 4.50 x 6.00

Weight

- 1.7 pounds

Supported Devices and Performance

PXG performance will vary depending upon the number and type of connected devices. This is driven by the following:

- Each supported device has a distinct number of channels to report back to the PXG, ranging from as few as 4 to over 900
- The channels are prioritized
- Device protocol, Modbus or INCOM
- Baud rate setting

For this reason, a PXG modeling tool has been developed to assist in understanding the expected performance for a given application since all systems are unique. This tool can be found at www.eaton.com/pxg. For a high level performance comparison, see the table below for three examples.

How long does it take	For this combination of devices (all times in seconds)		
	64 INCOM / 32 Modbus	15 INCOM / 15 Modbus	5 INCOM
Between value change in the UI (INCOM 9600)—Priority 1	21.9	3.7	1.4
Between value change in the UI (Modbus 57600)—Priority 1	3.5	1.6	—
Between value change in the UI (INCOM 9600)—Priority 2	44.3	7.4	2.6
Between value change in the UI (Modbus 57600)—Priority 2	7.0	3.1	—
Modbus server pass-through response time (57600) (local connection)	0.061	0.059	—
For the UI to show an alarm (INCOM device)	17.0	3.0	3.0
To boot up (all devices communicating)	399.0	85.0	51.0

Regulatory and Standards Compliance

- UL 508, Standard for Programmable Controller Equipment
- FCC, Class A, Part 15, Subpart B, Sections 15.107b and 15.109b
- EN55022:2010/A1:2011 Class A and EN55024:2010 Information Technology Equipment
- EN 61326-1:2006 and EN 61326-2-2:2006 Electromagnetic Compatibility (EMC) in Industrial Environments

Note: Features and specifications listed in this document are subject to change without notice and represent the maximum capabilities of the product with all options installed. Although every attempt has been made to ensure the accuracy of information contained within, Eaton makes no representation about the completeness, correctness, or accuracy and assumes no responsibility for any errors or omissions. Features and functionality may vary depending on selected options.

Power Xpert Dashboard

General Description

The Power Xpert® Dashboard allows users to monitor and control Eaton electronic devices installed in an Eaton Magnum DS® low voltage or VacClad medium voltage switchgear assemblies and transformers as part of a unit substation. These devices include Eaton E-Series protective relays, Digitrip™ 1150 and 520MC trip units, Power Xpert meters, and Eaton diagnostic devices. The Power Xpert Dashboard can be mounted on the switchgear, on the wall in an enclosure, or in a kiosk. The wallmount enclosure or kiosk can be placed near the switchgear but outside the arc flash boundary to provide safe access to control and monitoring of the equipment.

It provides features such as:

- Open/close circuit breakers through Control Mode
- Enable Arcflash Reduction Maintenance Mode and see status
- Monitor or initiate a transfer scheme in a Main/Tie/Main switchgear and adjust timer settings and sequence details
- Ability to configure/monitor alarms for various devices
- Rich interface to monitor parameters of all devices and study the trends of those parameters

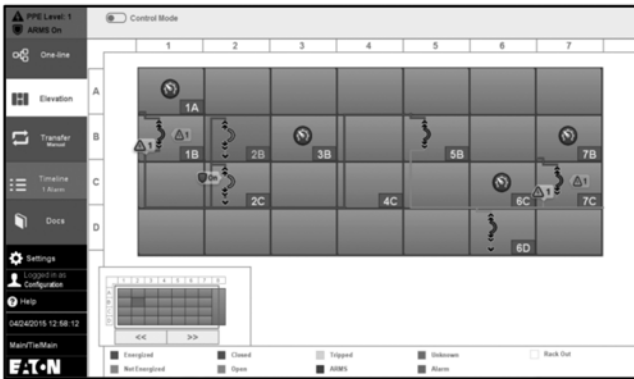

Elevation View



Timeline View

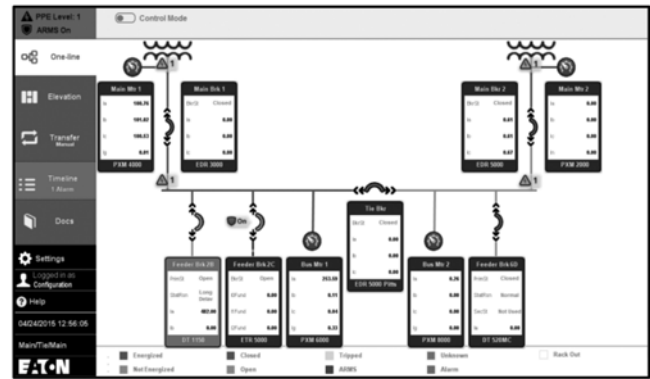

Online View

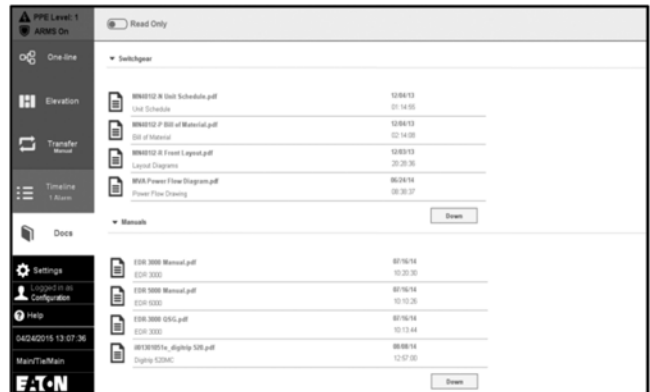

Docs

Power Xpert Dashboard

One-Line View

- The one-line view shows the lineup of all the configured devices with their top 5 parameters in the widget. It graphically represents the power flow between the configured devices

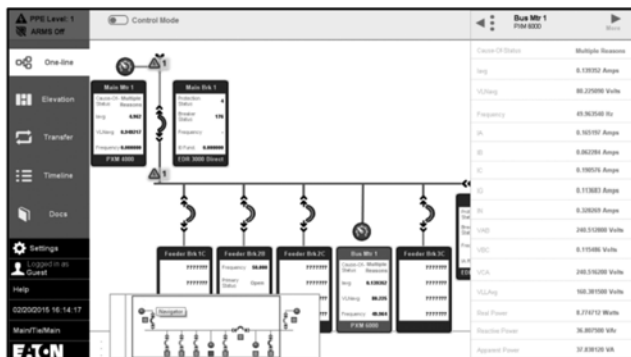

- Clicking on a widget provides the top 16 parameters of the device
- Clicking on the More button in the top parameters sidebar opens the Device Details page
- The Device Details page allows the user to customize top parameters, alarms, trends, etc.



- The navigator at the bottom can be used to move between various sections of the lineup
- The timeline is highlighted if any alarm is active

Elevation View

- Elevation view shows the front view of the switchgear lineup with the status of breakers and buses
- Any alarm or fault causes the corresponding compartment to be highlighted

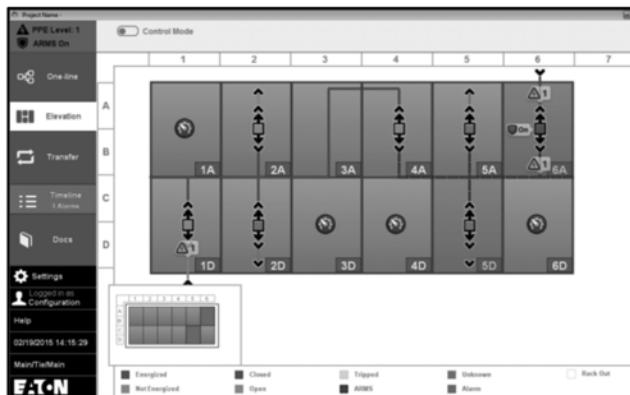

- The navigator shows the visible portion of the lineup. Clicking on a widget provides the top 16 parameters of the device

Control Feature

- Control Mode allows an authorized user to open/close breakers remotely. Control Mode can be entered from the one-line or elevation view
- Trip units and protective relays may be placed in the Arcflash Reduction Maintenance Mode and this is indicated by blue dashed bus lines

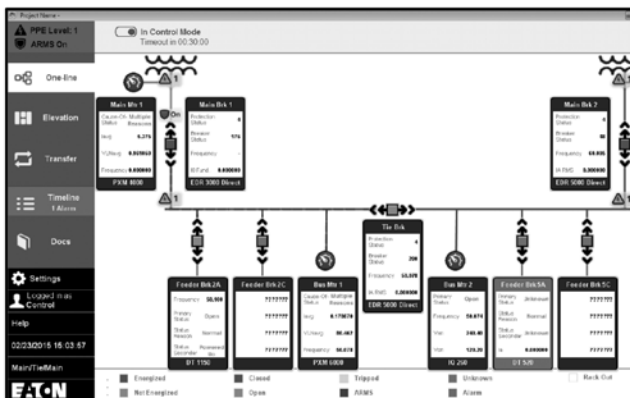

Power Xpert Dashboard

Timeline

- Clicking on an alarm opens the sidebar as follows. The alarm can be acknowledged by clicking the tab

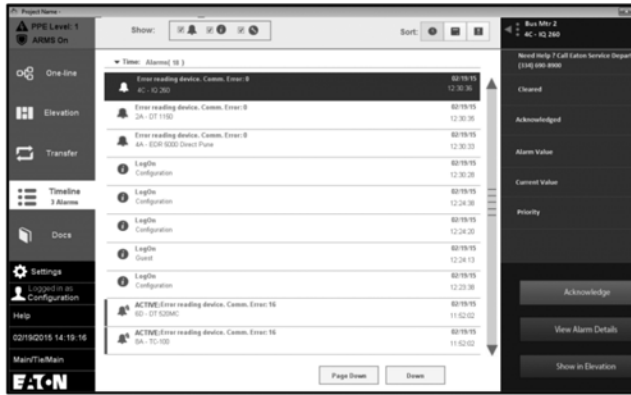

- Clicking on View Alarm Details opens the Alarm Details page. This page lists the alarm information such as time of occurrence, value at occurrence, and all the instances of the same alarm

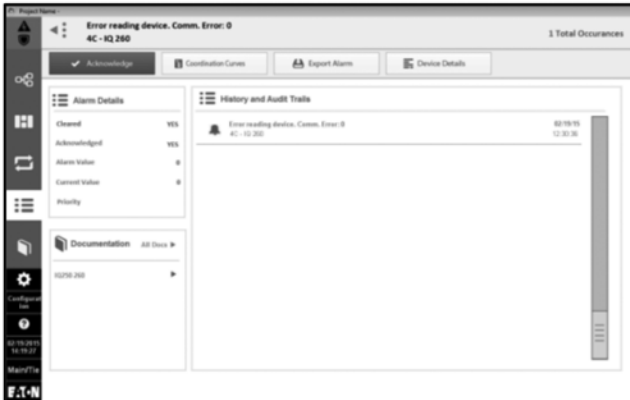

Transfer

- The Power Xpert Dashboard allows the user to monitor the transfer state and see a visual indication of the transfer process
- Various standard transfer schemes are supported using a switchgear installed programmable controller
- The user can set the transfer to be automatic or manual. The type of transition can be configured as Open/Closed
- Timing for various parameters can also be adjusted through the dashboard interface

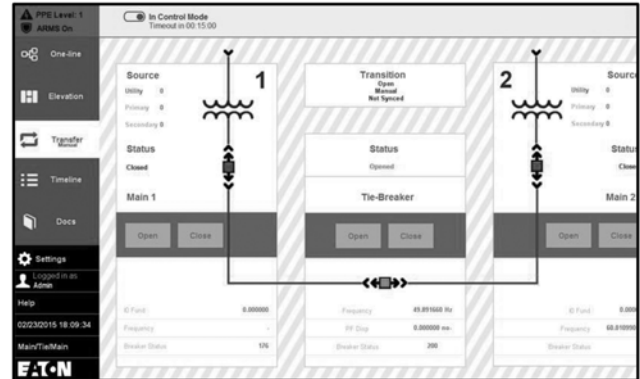

Docs

- Docs from the menu lists the support documents provided with the switchgear. One can navigate between various documents, including mechanical drawings, electrical schematics, component instruction books, and spare parts information using the right arrow at the bottom
- On entering the Edit Mode, more documents can be added under switchgear or manual

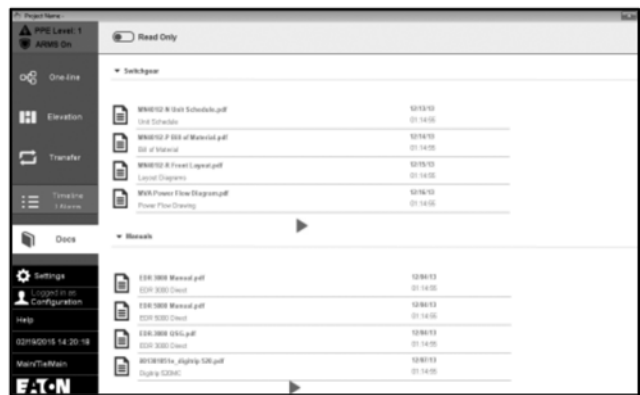

Power Xpert Dashboard

Device Configuration Using Settings Tab

- Add compartments and devices to switchgear using Settings tab

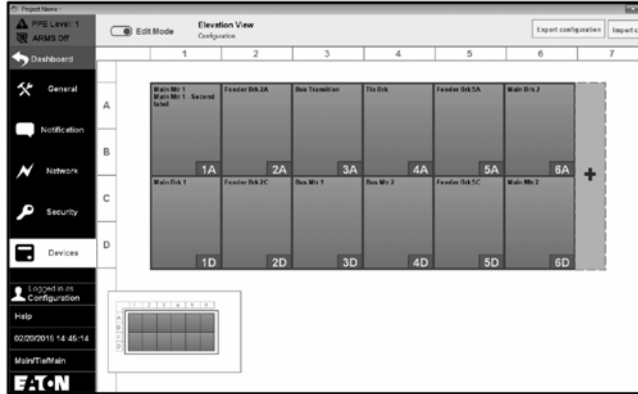

- In Edit Mode, click on a compartment (under Devices) to add a unit
- Under Add Devices, add the device that is to be monitored with its IP address



- Import a configuration that is already provided or save your custom configuration
- Under Settings>General, select the Application Mode (MVA/LVA)
- Select the source arrangement and breaker arrangement

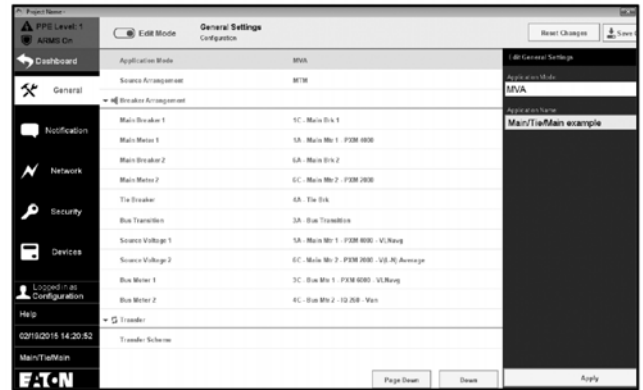

- Provision for transfer schemes settings
- Eaton Logic Controller settings provided for source transfer

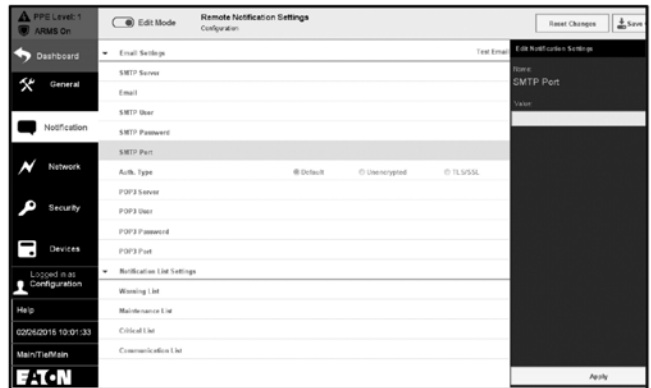

Power Xpert Dashboard

- The Notification tab allows the user to set up a mailing functionality. Any alarms, warnings, or alerts that are generated will be mailed to the configured mail ID

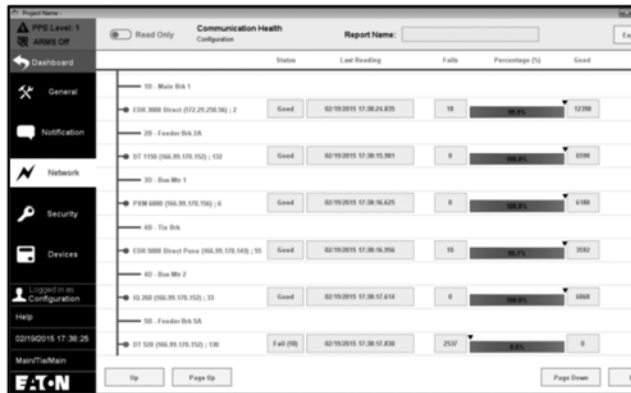

- Monitor the configured devices on the network (red: healthy, green: failed)
- The number of passed and failed packets is recorded
- Error message displayed for devices with failed communication
- Export the network information for later reference

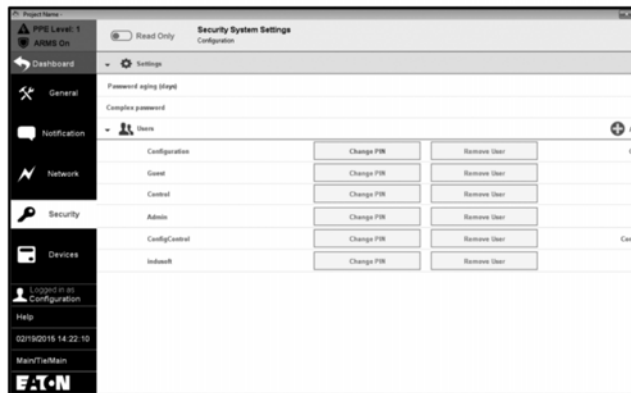

- The Security tab allows users to have a secured login
- A user can set a password for their account
- Complex password and password expiry feature
- A user with admin rights can add/remove users and change the passwords of all users

System Requirements

Compatible Devices

Eaton low and medium voltage switchgear with:

- Eaton Power Xpert meters
- Eaton Magnum DS circuit breakers with Digitrip 520MC or Digitrip 1150 trip units (Digitrip 1150 trip units required for remote breaker and Arcflash Reduction Maintenance Mode control)
- Eaton E-Series protective relays
- Eaton TC-50/TC-100 transformer temperature controllers
- Eaton InsulGard™ medium voltage insulation monitor
- Eaton Logic Controller (ELC)

Software Specifications

Server side:

- Visual Designer software version 7.1, Service Pack 3, Patch 3
- SQL Server 2008
- Microsoft® Access Database Engine 2010

Client side:

- Microsoft Internet Explorer® (IE) 9, 10, or 11

Hardware Specifications

- HMI module (XP503 WXGA, 1366 x 768 pixel resolution)

Power Xpert Insight

Power Xpert Insight

General Description

Eaton's Power Xpert Insight® is a power and energy monitoring system that is designed to be easy to install, easy to update and easy to use. It provides you with the energy and power information you need to:

- Keep the lights on with real-time, actionable alarms across desktop and mobile
- Save money and energy with easy to use and share energy reports
- Stay up to speed on your most critical devices with adjustable dashboards
- Drill into problems quickly with powerful graphics and detailed data
- Understand current issues and plan for future investments using trends and visualizations

2



One-Lines

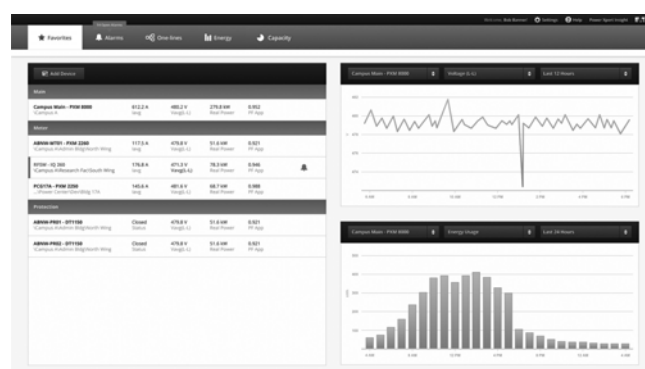

Favorites

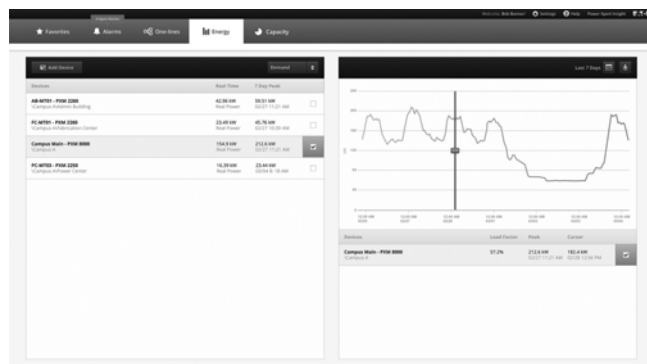

Energy

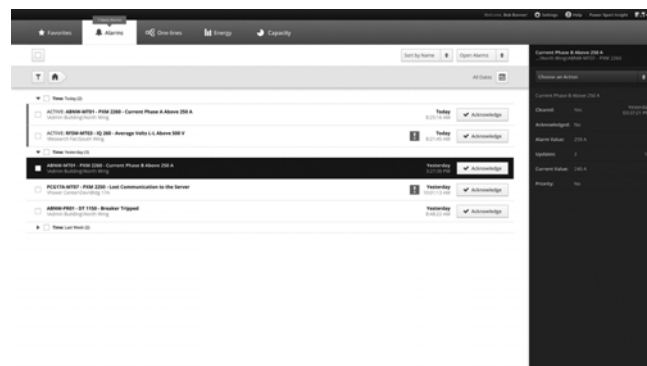

Alarms

Power Xpert Insight

Energy

- View energy usage and demand
- Select the desired devices and time range, 24 hours to a custom range
- Choose the type of graph that best suits; line or stacked bar chart
- Move the cursor over the graph to view detailed data
- Export data to a CSV-format file
- Expand to the Trend Viewer for additional information
- Energy usage is automatically added up for the devices shown in the table

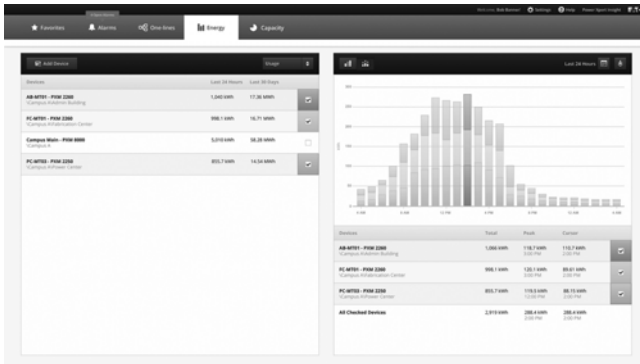
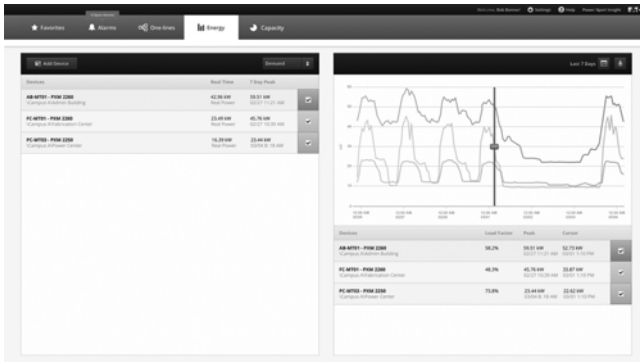

Alarms

- View color-coded alarms on one page (Black = Normal, Red = Alarm, Orange = Loss of Communication)
- Sort alarms by Time, Device or Priority for a specified time range, view by Alarm Status
- Acknowledge Alarms by individual device or group together
- Open the Alarm Pop Out to view additional data and add notes
- Export alarm history to a CSV-format file

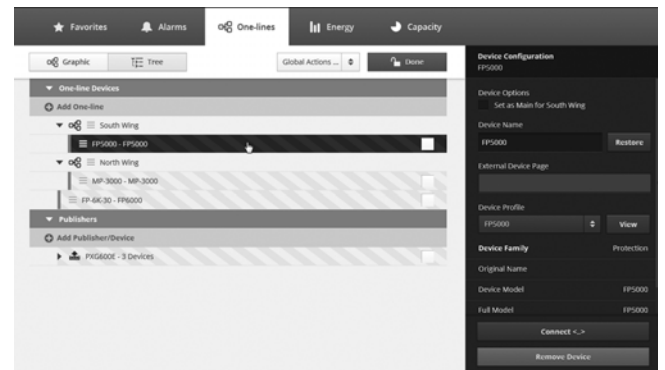
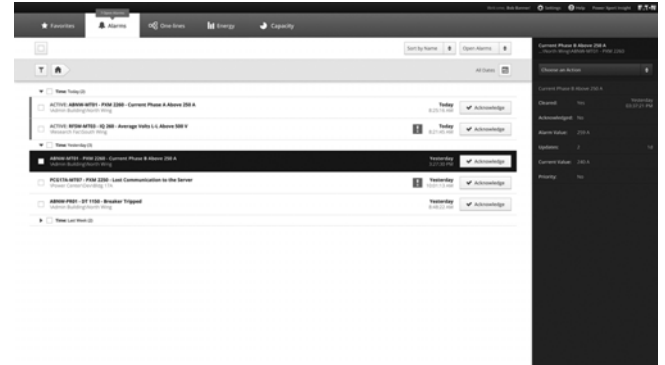

Power Xpert Insight

Capacity

- Benchmark capacity usage in real-time to determine tripping points and avoid downtime
- Custom trigger thresholds for cautionary and critical levels support all type of electrical environments and changing needs
- Simulate and trend with line graphics load additions prior to device installation to avoid tripping and downtime
- Forecast, budget and plan capacity requirements
- Proactively predict overall electrical system performance by modeling capabilities

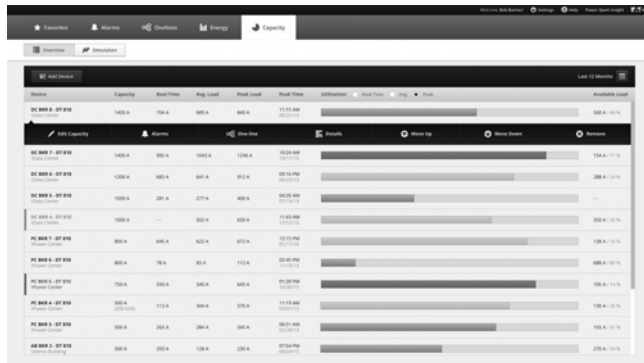

Favorites Dashboard

- Each user can create a unique dashboard to focus on the devices or systems that they are interested in
- Devices are displayed by device type (Main, Meter, Protection) and populate the top 4 channels for that device
- Alarm color-coding is automatically propagated across pages
- A quick Trend Graph and Energy Graph are also displayed for a selected device and channel over a time range up to 24 hours
- Quickly add or remove devices from the Favorites dashboard

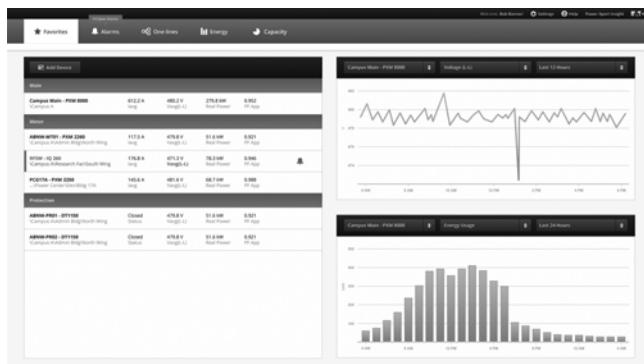

Modbus Protocol Adapter

The Protocol Adapter provides a Modbus server that regularly updates values for a specific set of Power Xpert Insight channels and makes these available as Modbus registers. You can specify the Power Xpert Insight channels you want and set the update characteristics of the Modbus server.

One-Lines

- Build an electrical one-line representation of the system with device widgets and the symbols library
- Drag-and-drop devices, lines, symbols where needed, add text boxes. Easily updated when devices are removed or added to service
- The top 4 device channels are automatically populated on the device widgets and alarm color-coding carries through on the one-lines
- Upload a unique background image
- Use the Device Tree to set up the one-line structure

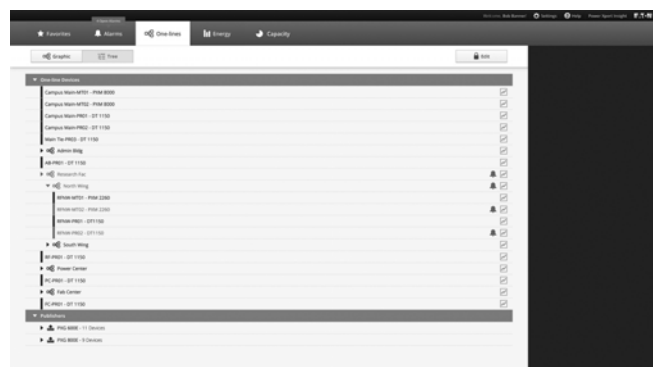
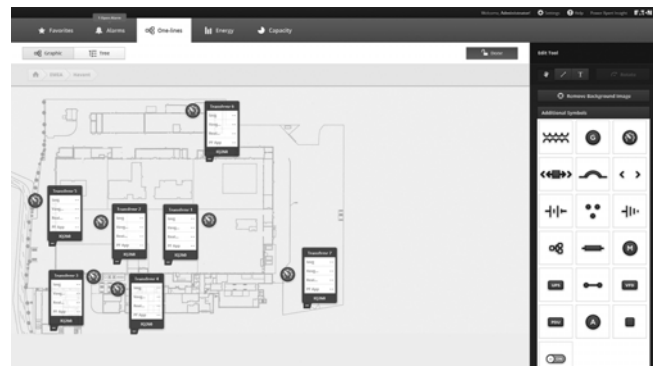

Event Notification

Power Xpert Notify will send out emails to selected recipients when alarms occur. The user can select the devices, recipients and frequency of notifications.

Offline Configuration

Power Xpert Insight provides the ability to completely configure a system in advance. The more you know about the final system, the more complete the offline configuration process will be.

- Configure Power Xpert Insight in advance using an Excel® spreadsheet (template available at Eaton.com/pxi)
- Upload the spreadsheet to an offline Power Xpert Insight system
- Set up one-line graphics in the offline Power Xpert Insight system
- Extract that entire system configuration

Upload the configuration into the target system when ready and connect when the devices are online.

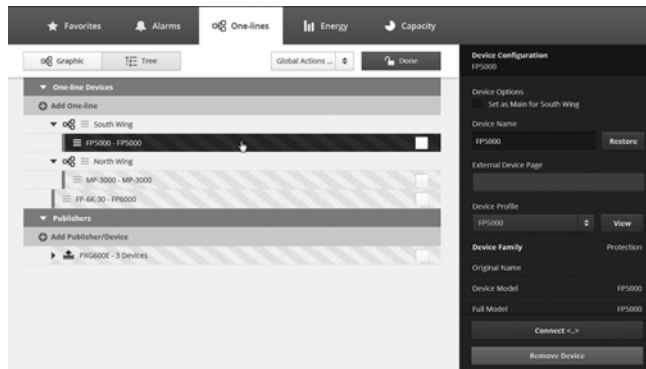

The screenshot shows an Excel spreadsheet with columns for device information. The columns are labeled: A, B, C, D, E, F, G, H, I, J, K, L, M, N, O, P, Q, R, S, T, U, V, W, X, Y, Z. The data includes device names, locations, and configurations.

Device	Location	One-Line Label	Model	Mark Y/N	Export Publisher/Device	Profile	External Device Page
One-line	Research Campus	400					
One-line	Fabrication Line	(Research Campus)	FAB				
One-line	Assembly Line	(Research Campus)	LINE				
Device	Assembly 400	(Research Campus)	4000	Y	PROGMA (I)	40 300 Series	
Device	FP10 @ 10	(Research Campus)	FP10		PROGMA (I)	None	
One-line	3D Printing Floor	(Research Campus)	3D		PROGMA (I)	FP5000	
Device	FP50 @ 10	(Research Campus)	FP50		PROGMA (I)	FP5000	
One-line	Robotics Lab	(Research Campus)	Rob. Lab	Y	PROGMA (I)	40 300 Series	
Device	4020	(Research Campus)	4020		PROGMA (I)	40 300 Series	
One-line	3D Printing Lab	(Research Campus)	3D Lab		PROGMA (I)	40 300 Series	
Device	4020@Floor 8	(Research Campus)	4020	Y	PROGMA (I)	40 300 Series	
Device	New Installation Monitor1	(Research Campus)	InstGuard		PROGMA (I)	None	
Device	New Installation Monitor2	(Research Campus)	InstGuard		PROGMA (I)	None	
Device	CAN1	(Research Campus)	CanGuard		PROGMA (I)	None	
Device	New Installation Monitor3	(Research Campus)	InstGuard		PROGMA (I)	None	
Device	DIM @ 10	(Research Campus)	Digital Input Module		PROGMA (I)	DIM	
Device	40A @ 10	(Research Campus)	40 Analyzer 4000/4020		PROGMA (I)	40 Analyzer	
Device	40B @ 10	(Research Campus)	40 Analyzer 4000/4020		PROGMA (I)	40 Analyzer	
Device	MP30 @ 1	(Research Campus)	MP-3000		PROGMA (I)	MP-3000	
Device	DP100 @ 1	(Research Campus)	Digital I/O		PROGMA (I)	Digital I/O	
Device	DP100 @ 2	(Research Campus)	Digital I/O		PROGMA (I)	Digital I/O	
Device	DP100 @ 3	(Research Campus)	Digital I/O		PROGMA (I)	Digital I/O	
Device	DP100 @ 4	(Research Campus)	Digital I/O		PROGMA (I)	Digital I/O	
Device	DP100 @ 5	(Research Campus)	Digital I/O		PROGMA (I)	Digital I/O	
Device	DP100 @ 6	(Research Campus)	Digital I/O		PROGMA (I)	Digital I/O	
Device	DP100 @ 7	(Research Campus)	Digital I/O		PROGMA (I)	Digital I/O	
Device	DP100 @ 8	(Research Campus)	Digital I/O		PROGMA (I)	Digital I/O	
Device	DP100 @ 9	(Research Campus)	Digital I/O		PROGMA (I)	Digital I/O	
Device	DP100 @ 10	(Research Campus)	Digital I/O		PROGMA (I)	Digital I/O	
Device	DP100 @ 11	(Research Campus)	Digital I/O		PROGMA (I)	Digital I/O	
Device	DP100 @ 12	(Research Campus)	Digital I/O		PROGMA (I)	Digital I/O	
Device	DP100 @ 13	(Research Campus)	Digital I/O		PROGMA (I)	Digital I/O	
Device	DP100 @ 14	(Research Campus)	Digital I/O		PROGMA (I)	Digital I/O	
Device	DP100 @ 15	(Research Campus)	Digital I/O		PROGMA (I)	Digital I/O	
Device	DP100 @ 16	(Research Campus)	Digital I/O		PROGMA (I)	Digital I/O	
Device	DP100 @ 17	(Research Campus)	Digital I/O		PROGMA (I)	Digital I/O	
Device	DP100 @ 18	(Research Campus)	Digital I/O		PROGMA (I)	Digital I/O	
Device	DP100 @ 19	(Research Campus)	Digital I/O		PROGMA (I)	Digital I/O	
Device	DP100 @ 20	(Research Campus)	Digital I/O		PROGMA (I)	Digital I/O	

Power Xpert Insight

System Architecture Diagram

Power Xpert Insight (PXI) seamlessly communicates over Ethernet with other Power Xpert-enabled products and third-party products via the Power Xpert bridge and Power Xpert Gateways.

Power Xpert Insight can be accessed via personal computer or Windows® Surface Pro tablet computer. It supports multiple Web browsers including Windows Internet Explorer®, Google Chrome™ and Mozilla® Firefox®.

For a complete list of supported devices, see the Hardware Compatibility List at Eaton.com/pxi.

2

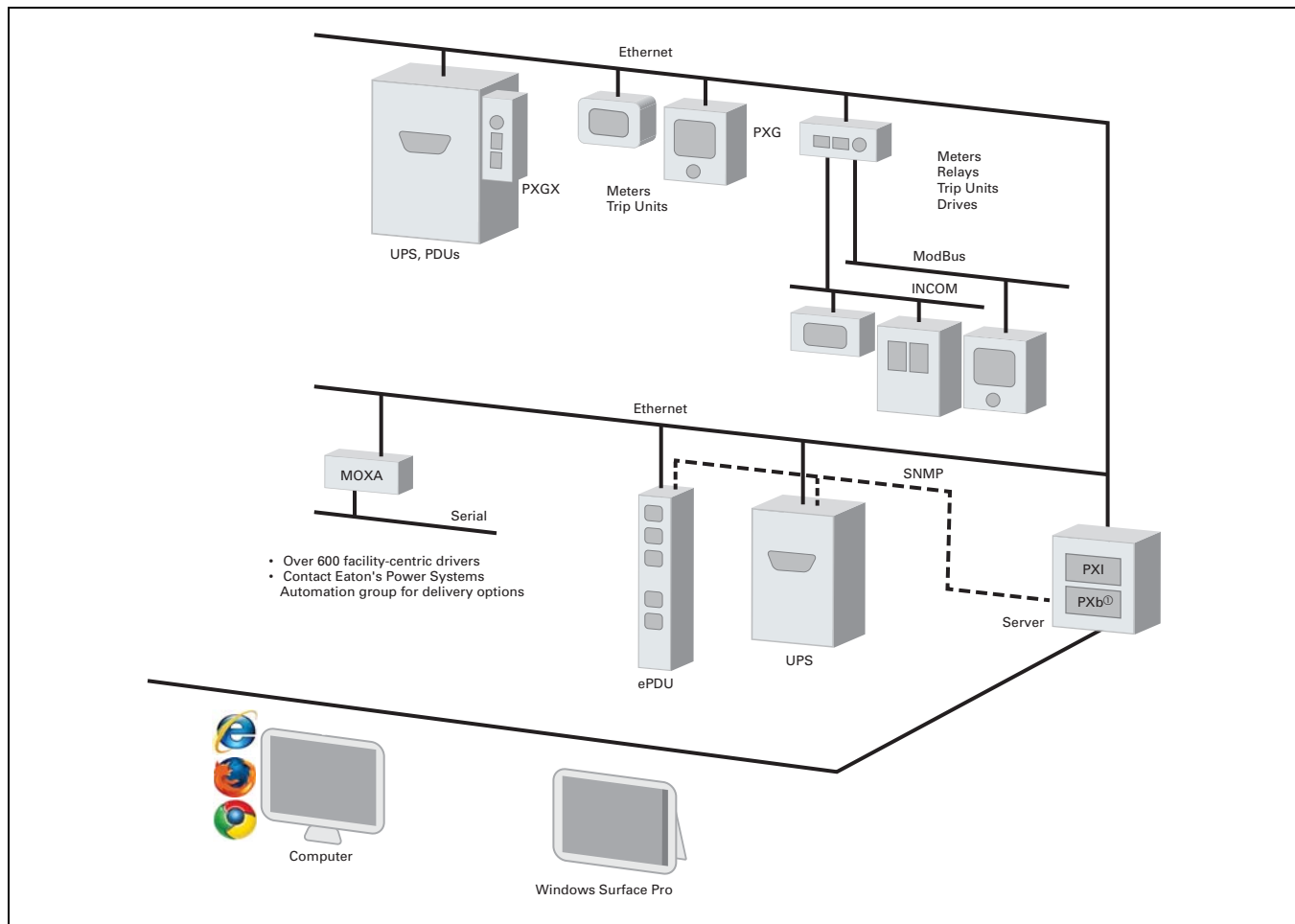

Figure 2.2-7. System Architecture Diagram

System Requirements

Table 2.2-3. Hardware Requirements

Power Xpert Insight requires a server-class machine with the following minimum hardware specifications:

Hardware	Specification
Processor	Quad Core
Memory	16 GB
Hard disk drive	100 GB—5 years estimated data storage
Video resolution	1920 x 1080

Table 2.2-4. Software Requirements

Description	Specification
Supported Operating Systems	
Server	Windows Server 2008 R2, Standard and Enterprise, SP1 Windows Server 2012 Standard and Datacenter
Client	Windows 7 Professional, Ultimate or Enterprise, x64, SP1 Windows 8 Professional/Enterprise X86 and X64
Supported versions of Microsoft SQL Server	SQL Server 2008 R2 Standard (and Standard for Small Business) SP2 SQL Server 2008 R2 Enterprise SQL Server 2012 Express with Advanced Services, Standard, Enterprise, Enterprise Core and Business Intelligence
If you do not have one of the above versions installed, Power Xpert Insight will install SQL Server 2012 Express with Advanced Services.	

Supported Web Browsers

Microsoft Internet Explorer (IE) 9, 10 or 11
Google Chrome
Firefox
Other browsers (such as Opera and Safari) that support Silverlight may also work, but are not officially supported by Eaton.

Table 2.2-5. Ordering Information

Description	Catalog Number
Power Xpert Insight	
PXI for up to 10 device connections	PXI-A
PXI for up to 25 device connections	PXI-B
PXI for up to 50 device connections	PXI-C
PXI for up to 100 device connections	PXI-D
PXI for up to 200 device connections	PXI-E
Power Xpert Insight Upgrades	
PXI 10 to 25 upgrade	PXI-A2B
PXI 10 to 50 upgrade	PXI-A2C
PXI 10 to 100 upgrade	PXI-A2D
PXI 10 to 200 upgrade	PXI-A2E
PXI 25 to 50 upgrade	PXI-B2C
PXI 25 to 100 upgrade	PXI-B2D
PXI 25 to 200 upgrade	PXI-B2E
PXI 50 to 100 upgrade	PXI-C2D
PXI 50 to 200 upgrade	PXI-C2E
PXI 100 to 200 upgrade	PXI-D2E
Service Packs	
Power Xpert 1-day startup Service Pack	PX-1S
Power Xpert 2-day startup Service Pack	PX-2S
Power Xpert 5-day startup Service Pack	PX-5S

Table 2.2-6. Power Xpert Software General Features

Features
General
Web browser user interface Web-based monitoring capabilities Downloadable software version updates
Event Notification
Event notification via e-mail notification Event Notification via pagers, text message or third-party interfaces Alarm state management
Event indicator displayed without Web page active Alarm/event searching and filtering Waveform attached to applicable power event
Web browser based waveform viewing Alarm capabilities based on device driven events
Analysis and Trending
Graphic trend viewer Chart or data option selection Multiple trends display
Multiple axis support View multiple variables (i.e., Ia, Ib, Ic, Vab, Vbc, etc.) for a single waveform Standard COMTRADE file format support
Customizable trend viewer look and feel Fixed or custom time frames Trend analysis capabilities Data export
Custom Graphics and Layouts
Custom graphics development via Web browser Four user view example templates included as standard iFrame capability
Browser portal widget support Streaming media support Graphic object library included as standard
ISO standard electrical picture objects available Graphic files import capability Graphic object animation capability
Gauge object library support External Web Links support Alarm bubble-up support through several page layers Trend object support
UPS Shutdown
File saving during shutdown Automatic, orderly and sequential shutdown Parallel redundant UPS shutdown capability
Security and Administration
Windows authentication security Two tier secure system access support SSL Secure Web browser access (support for HTTPS)
Time Synchronization
Time synchronization support for connected devices with 1 millisecond time resolution
Export and Integration
Extended Excel spreadsheet support SQL database query support
Logs
System log Error log
Service
Eaton help desk services (1-877-ETN-CARE) Turnkey startup service
System Backup
Power Xpert Software system backup
Documentation and Training Videos
System Administrator's Guide Power Xpert Software User's Guide Layout Manager Guide
Quick Start Guide Power Xpert Software introduction and training video Power Xpert Reporting introduction and training video

Foreseer Services

Foreseer® Services

Foreseer Software and Engineering Services (Foreseer Services) provide vendor independent, power and energy infrastructure integration solutions that help companies reduce energy consumption and unplanned downtime due to the failure of critical power, environmental, safety or security systems.

Turnkey software and connectivity solutions are coupled with state-of-the-art project management, systems design, third-party device integration, testing and custom application development to develop a comprehensive monitoring solution to meet your custom needs.

Foreseer Services is delivered in four categories, each offering a multitude of unique value-add services that you can discuss with your Eaton sales professional.

- Design services
- Installation services
- Commissioning services
- Follow-up services
- Hardware services
- Software services

Foreseer services is fully distributable to allow different monitoring capabilities to be deployed at different sites allowing you to purchase only what is needed. Many competitive systems offer a one-size-fits all type approach where you end up paying for more capacity than is needed. With Foreseer Services, you pay only for what you need, when you need it.

Foreseer Services Categories

Foreseer Services has three general categories:

- Foreseer Software Services
- Foreseer Project Management Services
- Foreseer Engineering Services

Foreseer Software Services—
Unique Features**Completely Scalable Solution**

Several classes, capable of handing up to 512,000 data streams (channels) while available to start with a low point of entry.

- Foreseer A-Class server software (up to 5,000 channels)
- Foreseer C-Class server software (up to 15,000 channels)
- Foreseer M-Class server software (up to 25,000 channels)
- Foreseer R-Class server software (up to 100,000 channels)
- Foreseer S-Class server software (up to 256,000 channels)
- Foreseer X-Class server software (up to 512,000 channels)

Redundant, Worldwide Coverage

The inclusion of one or more extra Foreseer servers provides the highest possible levels of system reliability. In the unlikely event that one Foreseer server fails then the remaining servers can carry the load of the power monitoring system.

With the Manager of Managers (MOM) software option, data from one server can be monitored alongside data from other servers, enabling you to aggregate multiple Foreseer sites into a single system.

Data Gathering, 24/7

A proactive algorithm gathers data 24/7, enabling you to sample data points from thousands of devices, every second.

User-Defined Formulas

Information from multiple sources and systems can be inserted into user defined formulas, providing knowledge for informed decision making.

Extensive Device Driver Library

Foreseer Software Services enables the full-scale integration of third-party products. A device library of over 600 drivers has been developed. For a full list of compatible devices, see the Foreseer services/hardware compatibility list at www.eaton.com/foreseer.

Trend Analysis

High performance analysis and forecasting tools assess equipment performance specifications including cause analysis, impact analysis, capacity planning, preventive maintenance assessments and trending.

Custom User Interfaces

Mimic graphics, dynamic one-line views, dashboards, 3D renderings and virtually any custom view to help operators manage their facility.

Web Browser Access—Unlimited Seats

Web browser access enables easy system access. Multiple users can access Foreseer software without the need for additional client seat licenses.

Alarm Notifications

For each channel being monitored, you can assign up to four alarm thresholds—from routine maintenance alerts to system failure—plus handling instructions and escalation procedures for each.

Foreseer Project Management Services

Each Foreseer integration project can be customized. See **Figure 2.2-8** for an overview of project flow.

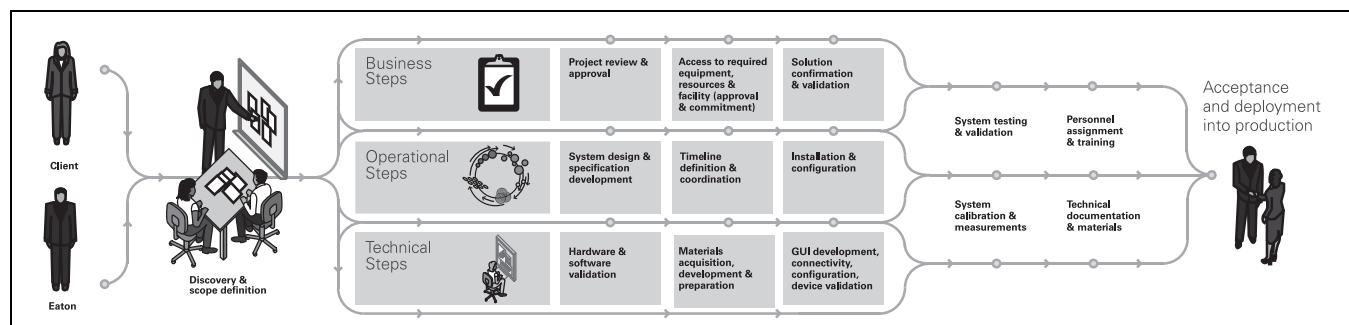

Figure 2.2-8. Foreseer Project Management Services

Foreseer Engineering Services

Design Services

After extensive assessment of your requirements and the existing device and facility infrastructure, the Foreseer design services team configures your system, complete with a bill of materials and recommendations unique to your needs. Specification development, drawings and detailed documentation for your project is part of this step. Third-party device support and communication interface planning is critical, including driver development and enhancement, if necessary. User interfaces are designed with default views to meet your specifications.

Installation Services

Installation services team members are with you from project initiation to handing over the Foreseer system when work is complete. Tasks include:

- Startup needs, testing and customization
- Drawings and custom graphic layout development
- Customized device gauge graphics and status indicators
- Third-party software integration
- Custom software and application development
- Setup and configuration of reporting packages and basic Foreseer training

Commissioning Services

Commissioning services consist of overall and tiered systems testing and full point-to-point system commissioning options.

Post Project Services

Once your system is successfully deployed, the Foreseer Service team is available to provide ongoing services such as system expansion, upgrades, troubleshooting and support, and advanced Foreseer training. Customized support contracts are available to tailor toward customer needs and requirements.

Custom Foreseer Services Applications

Management Dashboards

Standard with all new deployments, Foreseer's management dashboards provide high-level facility information for one-stop overview management. Utilizing Foreseer's powerful derived equations, measurables like utility power availability, emergency power availability, facility efficiency, environmental impact, facility environment, facility cooling, outside weather conditions, security system(s) status, fire system(s) status, monitoring system status, and others are available to provide quick glance management of a facility.



Eaton Powerware UPS-Primary View

Calculates DCiE and PUE

Use Foreseer Software Services Power Xpert Reporting option to automatically calculate Data Center Infrastructure Efficiency (DCiE) and Power Usage Effectiveness (PUE). These industry-standard efficiency metrics help IT managers to understand and to track how efficiently their data center is running and how effective improvement efforts have been.

Energy Cost Allocation

Fair Share Utility Cost Distribution

Foreseer Software provides energy usage by individual circuit so each device can be a part of the energy management strategy. It even allocates electrical cost to individual and branch circuits, which can then be assigned to individual users of a department or device.

Power Density

Pinpoint Hot Spots in Your Data Center

Power density is a critical measurement as racks proliferate and expand from TCP/IP networks and servers and other elements of the infrastructure are placed into smaller areas. Foreseer Software manages power density by device, for a single rack, floor or an entire building, allowing identification of overloaded racks and incorrect power drains due to device failure.

Growth Planning

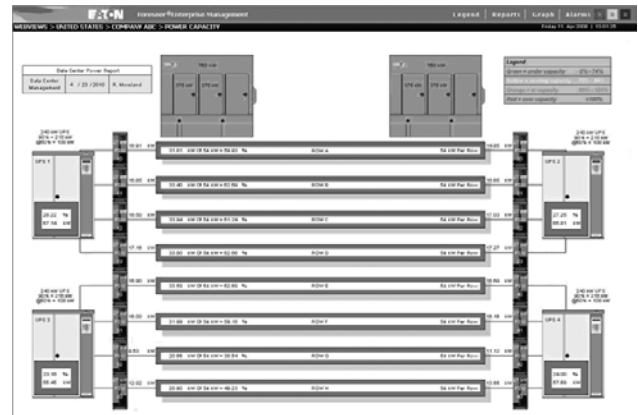

Power Capacity View

The Power Capacity View provides an at-a-glance simple analysis of the data center's electrical capacity. Normal, cautionary and alarm events are triggered automatically, both online and remotely once a threshold has been reached. Mapping the data center's capacity is critical for power, cooling and redundancy planning. With Foreseer Software projection graphing capability, data center managers can easily predict when they are going to hit a capacity threshold going into the future and can prepare accordingly.

Plan with the Electrical Capacity Planning Tool

Demand on devices grows as organizations expand. While average demand may not be a concern, peak demand is. Foreseer software tracks the kW and kVA over time, immediately informs of peak levels, and projects future demands based on past usage. Assisting in planning for electrical upgrades and/or changes to the power system to support changing load patterns.

Foreseer Services

Load Balancing

Prevent Unbalanced Loads

Improper load balancing contributes to harmonic distortion. Foreseer software tracks load levels by phase, giving instant notification when extreme imbalances begin to occur, and providing the knowledge to take the necessary steps to

re-distribute the load. Foreseer software visually illustrates the load balance of a device or system in real-time, while showing what the balanced model should be. You see the current state, the worst-case scenario and the proper load.

2

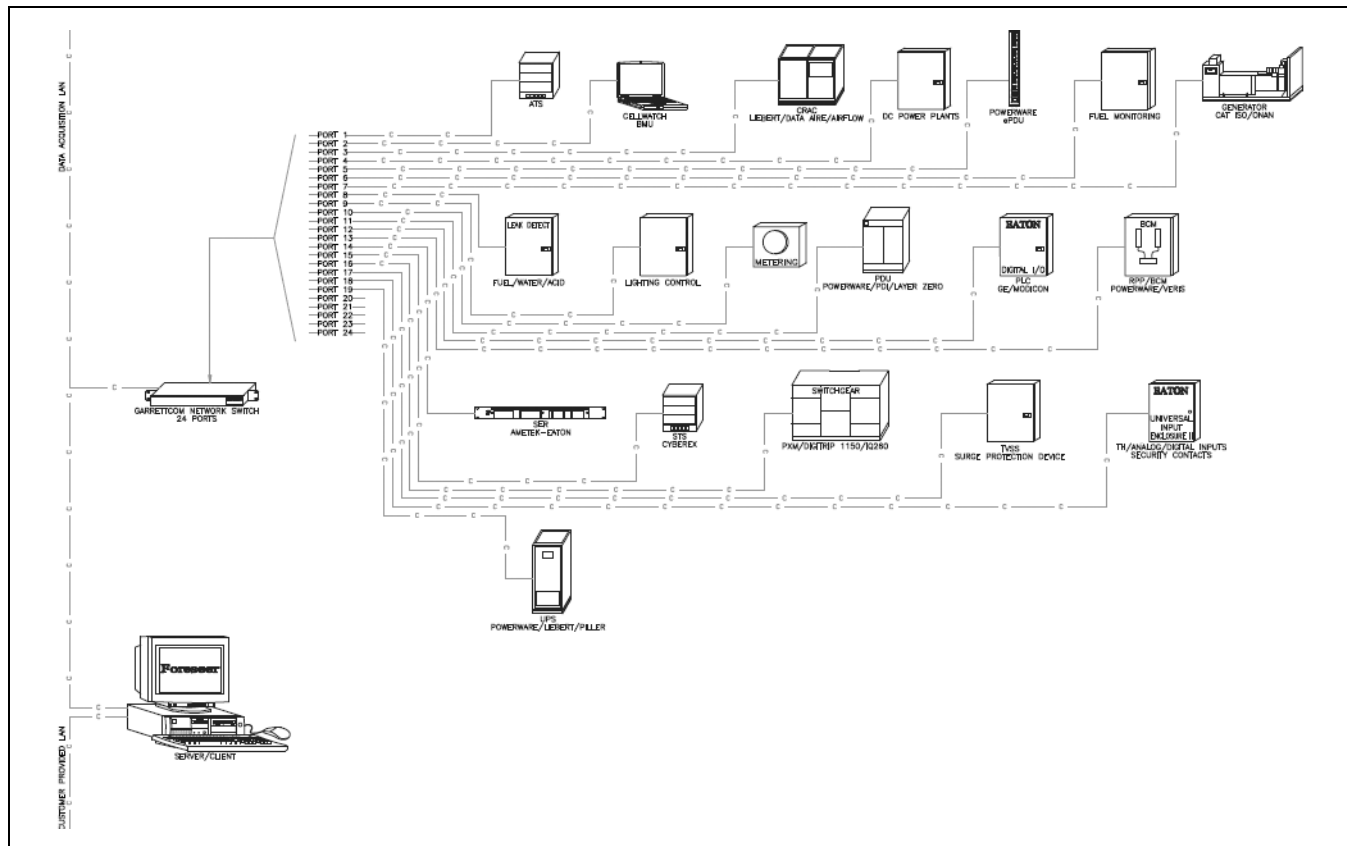

Figure 2.2-9. Data Center/Co-Location Device—The typical Data Center/Co-Location device mixture includes a large variety of power distribution, cooling, environmental monitoring, lighting, safety and security, backup and emergency power systems that have been purchased over a long period of time. Foreseer Services integrates all of these systems into a simple, single software monitoring package. Support for metering and energy measurement, including greenhouse gas monitoring, are requirements that need to be taken into consideration as well as, for example, Building Management System integration.

A/C Control Client Software



AC Control-Zone Assignment

Take Control of Your Environment

The Foreseer software A/C interface offers comprehensive monitoring and optional lead/lag control for Air Flow, Data Aire and Liebert System 3 air conditioning units. Lead/lag control and scheduling is viewable via a Web-browser and is controllable with the proper user authority.

Maintenance Scheduler

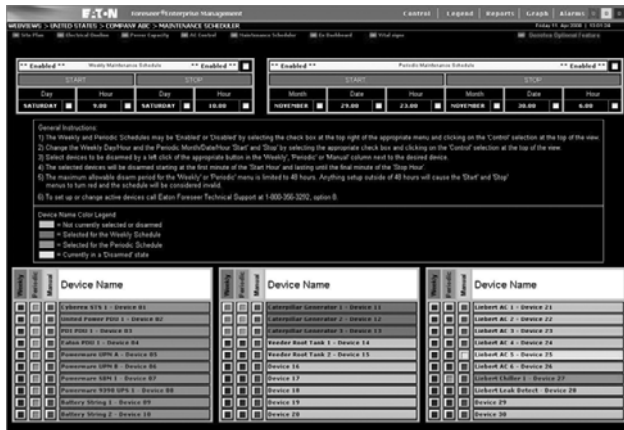

Maintenance Scheduler

Eliminate the Hassles

The Foreseer software maintenance scheduler offers the ability to preset scheduled (weekly or periodic) maintenance windows within the system to disarm selected devices on which maintenance will be performed. Disarming the devices allows continued monitoring and archiving during the maintenance period while disabling alarms and preventing unnecessary notification of personnel.

Foreseer Services Available Options

Power Xpert Reporting

Eaton's Power Xpert Reporting works in conjunction with Foreseer Software allowing a view past individual measurements, trend graphs and events. It consolidates complex data from a multitude of devices from around the globe into easy-to-understand graphical reports. It provides a standard set of reports for the most common report requests. Simply choose from 10 ready-to-go report templates. Power Xpert Reporting can be set to run the report automatically and send you new, updated reports via e-mail at predefined intervals.

Manager of Managers (MOM)

Provides a powerful means to integrate data from multiple locations where each location is running its own Foreseer software server. This unique feature provides a scalable system where the total number of integrated points on the centralized MOM server can be as large as 256,000 points.

Sequence of Events Recorder

Enables breaker status monitoring capability at a time stamping resolution of 1 millisecond. During a critical or catastrophic event, sequence of event information is captured by the recorder for retrospective analysis and root cause issue mitigation.

Secure Web Server (https)

Provides an encrypted means to protect all data that is viewed via a standard Web browser on the Internet or intranet. Using the OpenSSL package from the Internet, Foreseer software is able to provide 128 bit encryption between the Foreseer Software and the Web browser. Both registered certificates from a third-party provider or self-signed certificates are allowed to be used with this option.

Foreseer Gateway

Most facilities utilize multiple systems to help manage a facility including power monitoring systems, building management or automation systems, data center infrastructure management systems, control systems, etc. Successful and efficient management of a facility may depend on interaction of some of these systems. Foreseer's gateway interface makes this interaction with other systems simple and reliable, utilizing data availability through open protocols such as Modbus, SNMP, BACnet and OPC. Every data channel in the Foreseer server can be made available to another system at intervals up to once per second for processing or analysis.

Redundancy

Safeguards valuable information. The inclusion of one or more extra Foreseer software servers provides the highest levels of system reliability. In the event that one Foreseer software server fails, the remaining servers carry the load of the power monitoring system.

Foreseer Services

Data Acquisition Engine (DAE)

Designed specifically for geographically or physically removed sites where local IT expertise may not exist.

The data acquisition engine (see **Page 2.2-25** for details) automatically collects and sends data from critical infrastructure devices, and communicates that data back to the Foreseer software server. Using local processing and the shared bandwidth of an IP network, the DAE reduces the cost required to transmit data to the central server. The DAE also continues to operate independently and generate alarms even if the connection to the central server is unavailable, increasing the overall availability of the management system.

Data Acquisition Terminal (DAT)

Easily integrates monitored equipment and sensors located in small, networked remote sites. The DAT (see **Page 2.2-25** for details) employs standard Modbus communications to relay information to either a Foreseer software server or a data acquisition engine over a TCP/IP network. Data is packaged in sequential Modbus registers to enable optimum scan times without impacting network bandwidth.

Universal Input Enclosure (UIE2, UIE2+)

Provides network connectivity for analog and contact input information along with device server capability. Each enclosure contains from one to five input modules with pluggable connectors used for power and input wiring, enabling cost-efficient monitoring of equipment in small, remote facilities.

The universal input enclosure provides network connectivity for analog and contact input information along with the option for concentration of a variety of monitored points via several communication means at a single point. Each UIE2 contains up to five input modules with pluggable connectors used for power and input wiring, enabling cost-efficient monitoring of equipment in small, remote facilities. Serial-to-Ethernet conversion hardware and network switch may be added to give a single point of monitoring connection for all analog/digital contacts, serial-based devices and Ethernet-based devices, making the UIE2 an extremely flexible building block of a monitoring infrastructure.

To further expand the reach of Foreseer Services, several hardware options are offered.

The Foreseer data acquisition engine is designed specifically for geographically or physically removed Foreseer class sites where local IT expertise may not exist.

The Foreseer data acquisition terminal easily integrates monitored equipment and sensors located in small, networked remote sites.

The Foreseer universal input enclosure is designed for small remote sites containing equipment with several connectivity types.

Designed for small remote sites containing equipment with several connectivity types. The universal input enclosure provides modular terminations for analog contacts, such as flow metering and temperature/humidity sensors, and digital contacts, such as summary alarms and door open/close contacts, based on quantity and type for flexible integration into the Foreseer monitoring system. In situations where space is at a premium, the UIE2+ can be utilized to concentrate serial communicating wiring and Ethernet communication wiring and provide a single Ethernet connection out to the Foreseer system. Housed inside a NEMA 12 enclosure with all modules mounted and internal power connected, the UIE2 is a very contractor-friendly communication center of the Foreseer monitoring architecture.

Data Acquisition Engine (DAE)**Data Acquisition Engine (DAE)**

Designed specifically for geographically or physically removed sites where local IT expertise may not exist. The data acquisition engine automatically collects and sends data from critical infrastructure devices, such as UPS, generator and power distribution units, and communicates that data, as well as status and alarms, back to the centrally located Foreseer server. Using local processing and using the shared bandwidth of an IP network, the DAE reduces the cost required to transmit data to the central server. The DAE can also continue to operate independently and generate alarms even if the connection to the central server is unavailable, increasing the overall availability of the management system.

DAE Technical Specifications

- External power input: 115/230 Vac in, 5 Vdc 8 A out, optional—48 Vdc
- Ethernet: dual 10/100Base-T Ethernet ports
- Communications ports: four RS-232/422/485 and four USB ports
- Dimensions in inches (H x W x D): 3.50 x 17.00 x 11.00, 19.00-inch rack-mount with removable flanges
- Environment: 32 ° to 104 °F (0 ° to 40 °C), 0% to 90% noncondensing RH
- Monitoring: 3072 channels, maximum of 1536 analog

Data Acquisition Terminal (DAT)**Data Acquisition Terminal (DAT)**

Easily integrates monitored equipment and sensors located in small, networked remote sites. The DAT employs standard Modbus communications to relay information to either a Foreseer server or a data acquisition engine over a TCP/IP network. Data is packaged in sequential Modbus registers to enable optimum scan times without impacting network bandwidth.

DAT Technical Specifications

- External power input: 100/240 Vac, 47/63 Hz, 1 A (0.5 A at 240) optional—48 Vdc
- Ethernet: 10Base-T, status and activity LEDs
- Communications: Modbus RTU via UDP using TCP/IP Port 7010 or Modbus TCP
- Dimensions in inches (H x W x D): 1.75 x 19.00 x 4.63
- Weight: 3 lbs
- Environment: -4 ° to 185 °F (-20 ° to 85 °C), 0% to 90% noncondensing RH
- Discrete inputs: 16 channels configure as dry contact
- Relay outputs: 16 channels, SPDT configuration, contacts rated at 500 mA, 125 Vac
- Analog inputs: eight channels of 12-bit A/D up to 16 digital inputs

Power Xpert Reporting Software

Power Xpert Reporting Software

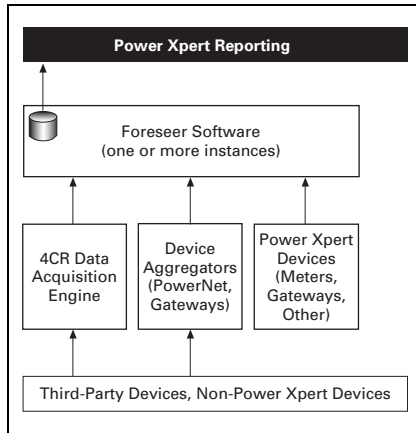
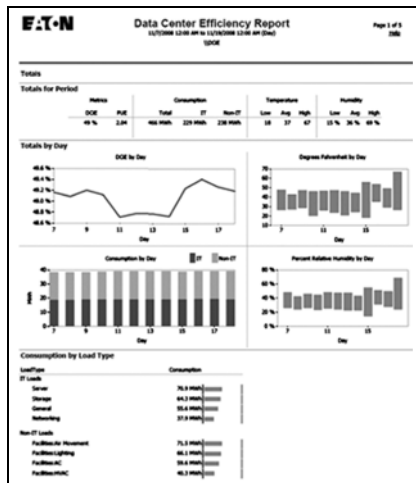

Figure 2.2-10. Power Xpert Reporting Architectural Overview

Power Xpert Reporting brings the power system information together to compare and contrast. Power Xpert Reporting provides a standard set of reports, including:

- **Data Center Efficiency Report:** A summary of data center infrastructure efficiency and power usage effectiveness, including such information as temperature and humidity, and energy consumption



Data Center Efficiency Report

- **Greenhouse Gas Report:** Captures the six offensive greenhouse gasses: carbon dioxide, sulfur dioxide, nitrogen oxide, mercury, methane and nitrous oxide broken down by selected locations within a facility

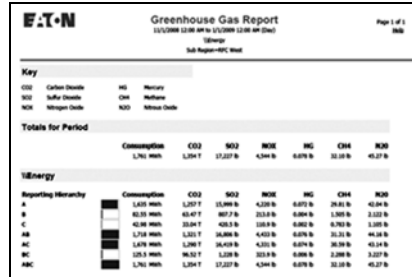

Greenhouse Gas Report

- **Utilities Report:** Captures consumption of water, air, gas, electricity and steam (WAGES)



Utilities Report

- **Capacity Summary Report:** The summary of top- and bottom-loaded circuits, as well as loading details for each circuit according to user-defined date/time range and facility hierarchy location

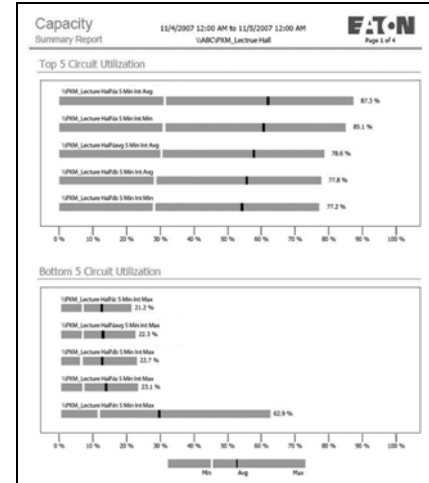

Capacity Summary Report

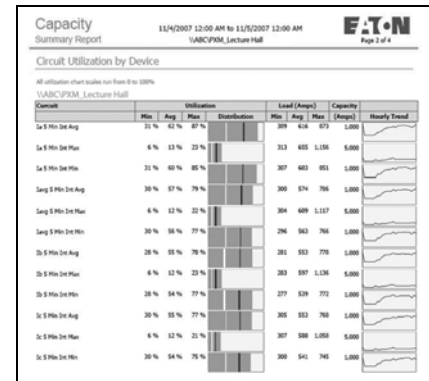

- **Branch Circuit Monitoring Report:** Determine branch circuit loading levels at a glance with color-coded graphics indicating loading status against capacity. Redundant sources can be reviewed, as well as single source loads

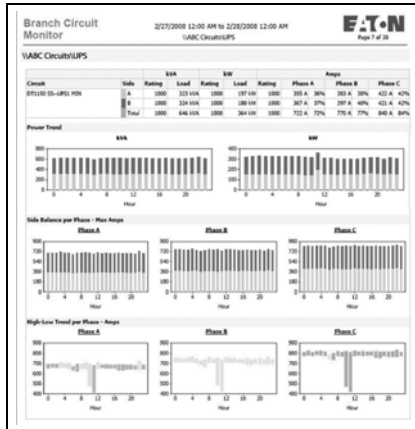
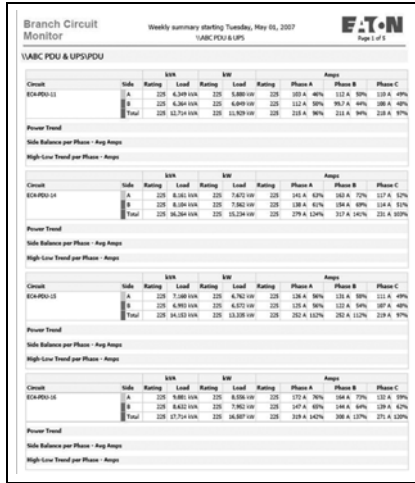

Branch Circuit Monitoring Report

- **Energy Summary Report:** The summary of consumption (kWh) and demand (kW) for a user-defined date/time range and facility hierarchy location

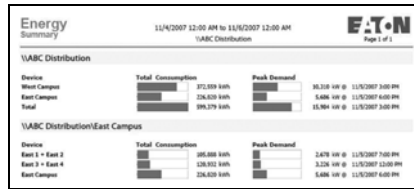
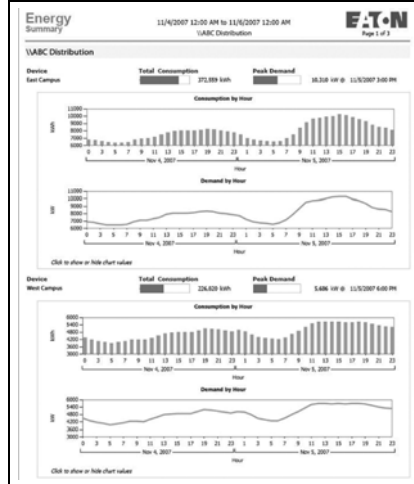

Energy Summary Report

- **Energy Cost Allocation Report:** The total energy bill dollar value or a cost per kWh across a facility hierarchy for a user-defined date/time range

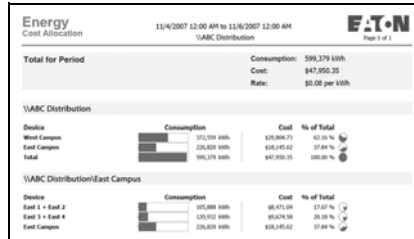

Energy Cost Allocation Report

- **Power Quality Report:** The distribution and trend for amps, volts and THD according to user-defined date/time ranges and facility hierarchy location

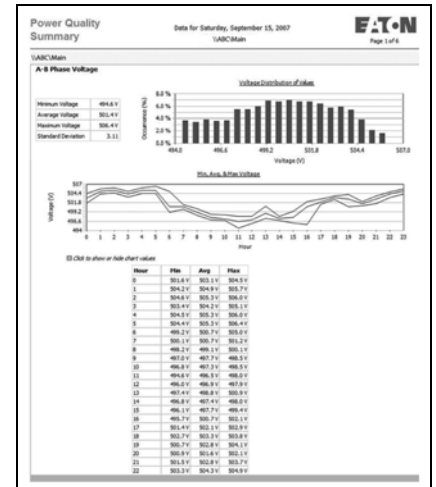
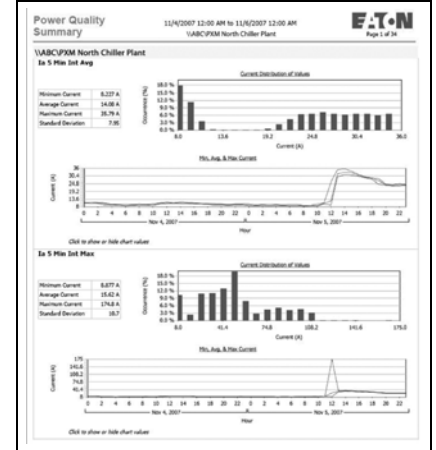

Power Quality Report

2

Power Xpert Reporting Software

- **Event Summary Report:** Provides a Pareto chart of events according to user-defined date/time ranges and facility hierarchy location

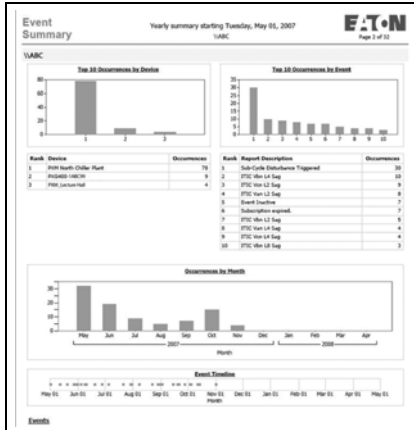

Event Summary Report

- **Joint Commission Report:** Standard Joint Commission Compliant Report supports hospital power test requirements. It checks events, key metrics of generators and automatic transfer switches (ATS) during generator testing at user-defined date/time ranges and facility hierarchy location

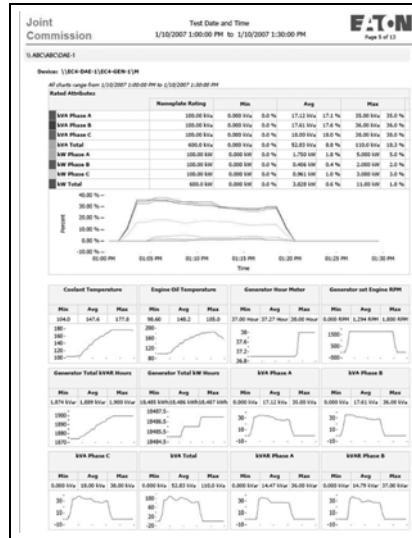

Joint Commission Report

Table 2.2-7. Power Xpert Reporting Software

Description	Catalog Number
Power Xpert Reporting	
Power Xpert Reporting—single source DB connection	PXR
Power Xpert Reporting—up to 2 source DB connections	PXR-2DB
Power Xpert Reporting—up to 5 source DB connections	PXR-5DB
Power Xpert Reporting—up to 10 source DB connections	PXR-10DB
Power Xpert Reporting—up to 25 source DB connections	PXR-25DB
Power Xpert Reporting—up to 50 source DB connections	PXR-50DB

MINTII RS-232 Converter

MINTII RS-232 Converter



MINTII RS-232 Converter

General Description

Applications

Converts a network of power management software devices to ASCII RS-232 format for access through a serial port of a PC, laptop, or Programmable Logic Controller (PLC).

Displayed Parameters

- Eaton's MINTII provides access to all parameters monitored over a system monitoring system such as Power Xpert Software or Foreseer Services
- Supports INCOM networks up to 8500 ft (2590 m) in distance and device counts up to 1000

Physical Characteristics

- Suitable for panel mounting or desktop use
- 120 Vac power cord included for plug-in to standard duplex receptacle
- Height: 2.25 inches (57.2 mm)
- Width: 11.50 inches (292.1 mm)
- Depth: 4.25 inches (108.0 mm)

Technical Data and Specifications

- Temperature: 0° to 60°C
- Humidity: 0–95%
- Power: 120 V
- Speed: 1200, 2400 and 9600 baud (INCOM), 19.2K baud (RS-232)
- Communications: INCOM, RS-232

Product Selection

Table 2.3-1. MINTII RS-232 Converter

Description	Catalog Number
Master INCOM Network Translator II	MINTII

Master INCOM Network Translator II

The Master INCOM Network Translator II (MINTII) converts the twisted shielded pair network of INCOM devices to an RS-232 signal. This signal can be accessed by PLCs, computer serial ports and building management system serial interface cards. The MINTII is also often applied as an interface to standard line drivers and converters to allow communication through dedicated telephone lines, dial-up modems, fiber-optic line drivers, radio frequency or wireless modems.

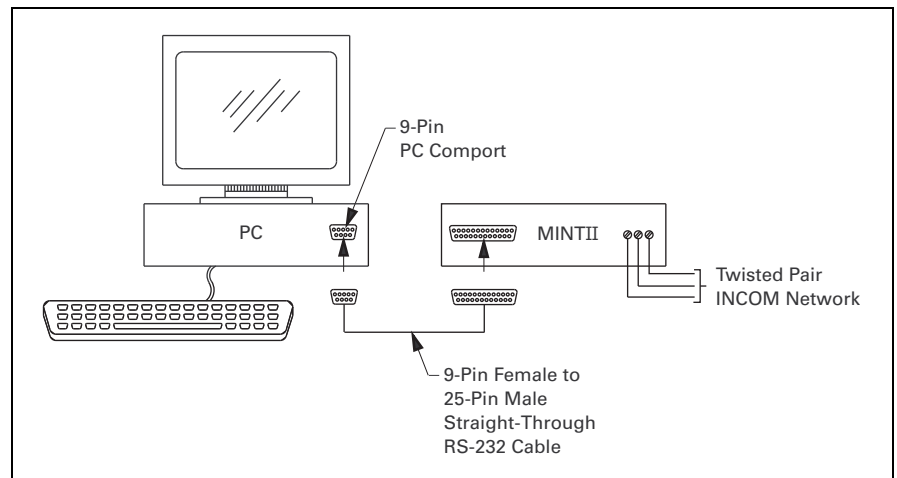

Figure 2.3-1. MINTII Connection Diagram for Use with a PC

mMINT

mMINT



mMINT Module

General Description

The mMINT (Modbus Master INCOM Network Translator) Module is an Eaton accessory product that will provide communication between a Modbus RTU network and an INCOM (Industrial COMMunications) network (see Figure 2.3-2). This module is transparent to the Modbus network. It communicates to a master on the Modbus network using the Modbus RTU (Remote Terminal Unit) protocol. It communicates to slave devices on the INCOM network using the IMPACC (Integrated Monitoring, Protection, and Control Communication) protocol. The catalog number of this product is mMINT.

Features

The mMINT module is a slave device on the Modbus network and as such requires a master that will exchange register objects with the mMINT module.

- Handles generic pass-through commands (Modbus/INCOM/Modbus)
- Capable of passing Modbus register objects from Eaton's existing products and newer PnP (Plug-'n-Play) products to a Modbus RTU master
- Data in IEEE Floating Point format and fixed point
- Modbus RTU communications data transfer rates of 1200, 9600 or 19200 baud with one start bit, eight data bits, no parity, and either one or two stop bits
- Up to 32 products connected to INCOM network port (246 unique addresses maximum)
- Flashing Status LED to indicate an active module

- LED indicators for INCOM transmit and receive communications exchanges
- LED indicators for Modbus RS-485 transmit and receive communications exchanges
- Input power for the module from either 120 Vac or 24–125 Vdc
- DIN rail mount package
- 0° to 60°C ambient operation

Module Mounting

When mounting the mMINT, verify that an 11 mm H x 28 mm W DIN rail is used and that it is within an enclosed space.

Simplified Wiring Rules

INCOM Network

The following simplified rules apply to a given system consisting of a single daisy-chained main cable link between master and slave devices (see Figure 2.3-2). For more complex considerations including star configurations, please refer to the IMPACC wiring specification T.D. 17513.

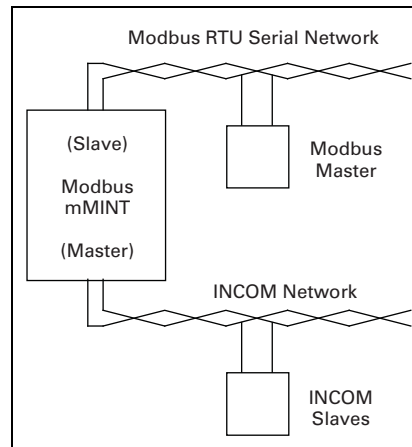

Figure 2.3-2. mMINT in a Communications Network

- Recommended INCOM cable styles are Belden 9463 or C-H style 2A957805G01
- The maximum system capacity is 10,000 feet of communications cable and 32 slave devices on the INCOM network under the mMINT
- Non-terminated taps, up to 200 feet in length, off the main link are permitted, but add to the total cable length
- Make sure that there is twisted-pair wire that is recommended for IMPACC network use. Use shielded twisted-pair wire to connect each slave to the INCOM network, daisy-chain style. The polarity of the twisted pair is not important

Modbus RS-485 Network

The following simplified rules apply to a given system consisting of a cable link between master and slave devices (see Figure 2.3-3). For more complex configurations, please refer to standard Modbus RTU wiring specification rules for the RS-485 network.

- The recommended Modbus cable has twisted-pair wires (24 AWG stranded 7x32 conductors with PVC insulation) having an aluminum/mylar foil shield with drain wire
- The maximum system capacity is 4000 feet of communications cable and 247 devices on the Modbus RTU network
- Make sure that there is twisted-pair wire that is recommended for Modbus RTU network use. Use shielded twisted-pair wire to connect each slave to the Modbus RTU network, daisy-chain style. The polarity of the twisted pair is critically important

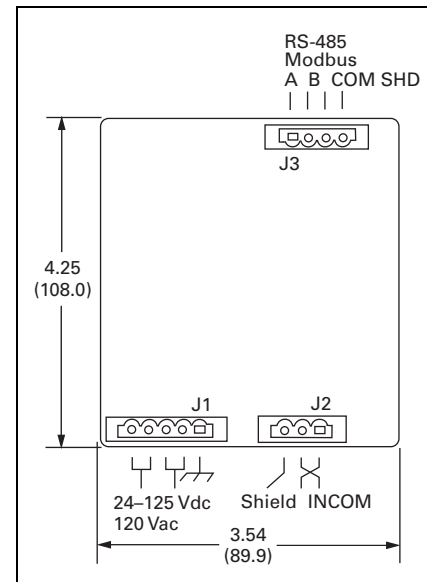

Figure 2.3-3. mMINT Module Dimensions

Burden

- 24 Vac/dc 3 VA

Safety Standards

- UL
- CSA
- CE mark

Communications Speed

- INCOM: 1200, 9600 baud
- N2 Bus: 9600 baud

PMINR

PMINT



PMINT Module

General Description

The PMINT (PROFIBUS DP—Master INCOM network translator) module is an Eaton accessory product that will provide communications between a PROFIBUS DP network master and an INCOM (INDustrial COMMunications) based Digitrip™ Magnum® 520MC or 1150 trip unit. The module is transparent to the PROFIBUS network master. It communicates to a master on the PROFIBUS network using the PROFIBUS-DP-V0 protocol. It communicates to a slave Magnum trip unit device on INCOM.

Features

The PMINT module is a slave device on the PROFIBUS network and as such requires a PROFIBUS master that will interrogate the PMINT module.

- The PMINT uses the VPC3+C Pro-fiChip integrated circuit, providing PROFIBUS communications support with automatic recognition of data transfer rates up to 12 Mbits/s
- Flashing Status LED to indicate an active module
- LED indicators for PROFIBUS SYSFAULT and BUSFAULT
- LED indicators for INCOM transmit and receive communications exchanges
- Input power for the module from either 100–240 Vac or 24–150 Vdc
- DIN rail mount package
- –40° to 85 °C ambient operation

INCOM Connection

INCOM communications is based on a master-slave protocol. The PMINT is a master on the INCOM connection and continually obtains data from the attached trip unit. Reference material pertaining to INCOM can be obtained from <http://www.eaton.com>, then search on 17384.

- IL17384—Part A: INCOM Communications Standard
- IL17384—Part C: Protective Relays and Trip Units

The following simplified rules apply to a given system consisting of an INCOM master and the slave trip unit.

- Recommended INCOM cable styles are Belden 3073F or Eaton style 2A957805G01
- A 100 ohm terminating resistor is required across the INCOM carrier signal pair at the trip unit
- The maximum system capacity is 8000 feet of communications cable on an INCOM network under the PMINT

Make sure that there is twisted pair wire that is recommended for INCOM network use. Use shielded twisted pair wire to connect between the PMINT and the INCOM communications based trip unit. The polarity of the twisted pair is not important.

PROFIBUS DP RS-485 Network

Reference material pertaining to PROFIBUS can be obtained from the <http://www.PROFIBUS.com> Web site. Refer to the PROFIBUS DP standard for transmission using copper cables (RS-485). A 9-pin D-SUB connector interface is provided.

This page intentionally left blank.