

ITEM NO.	NAME	MATERIAL	NOTES
1	COVER	PA66	UL94-V0, GREY
2	LINK PIN	COPPER ALLOY	TIN PLATED
3	SCREW	STEEL	M4/ZN PLATED

REVISIONS			DATE	ECN	BY
REV	ZONE	DESCRIPTION			
A	-	INITIAL RELEASE	09/24/2012	BU-J12374	TJN

PART NUMBER	NUMBER OF POLES	MARK	"A" DIM	"B" DIM
DS10-02P	2	DS10-02P	10	18
DS10-03P	3	DS10-03P	20	28
DS10-04P	4	DS10-04P	30	38
DS10-10P	10	DS10-10P	90	98

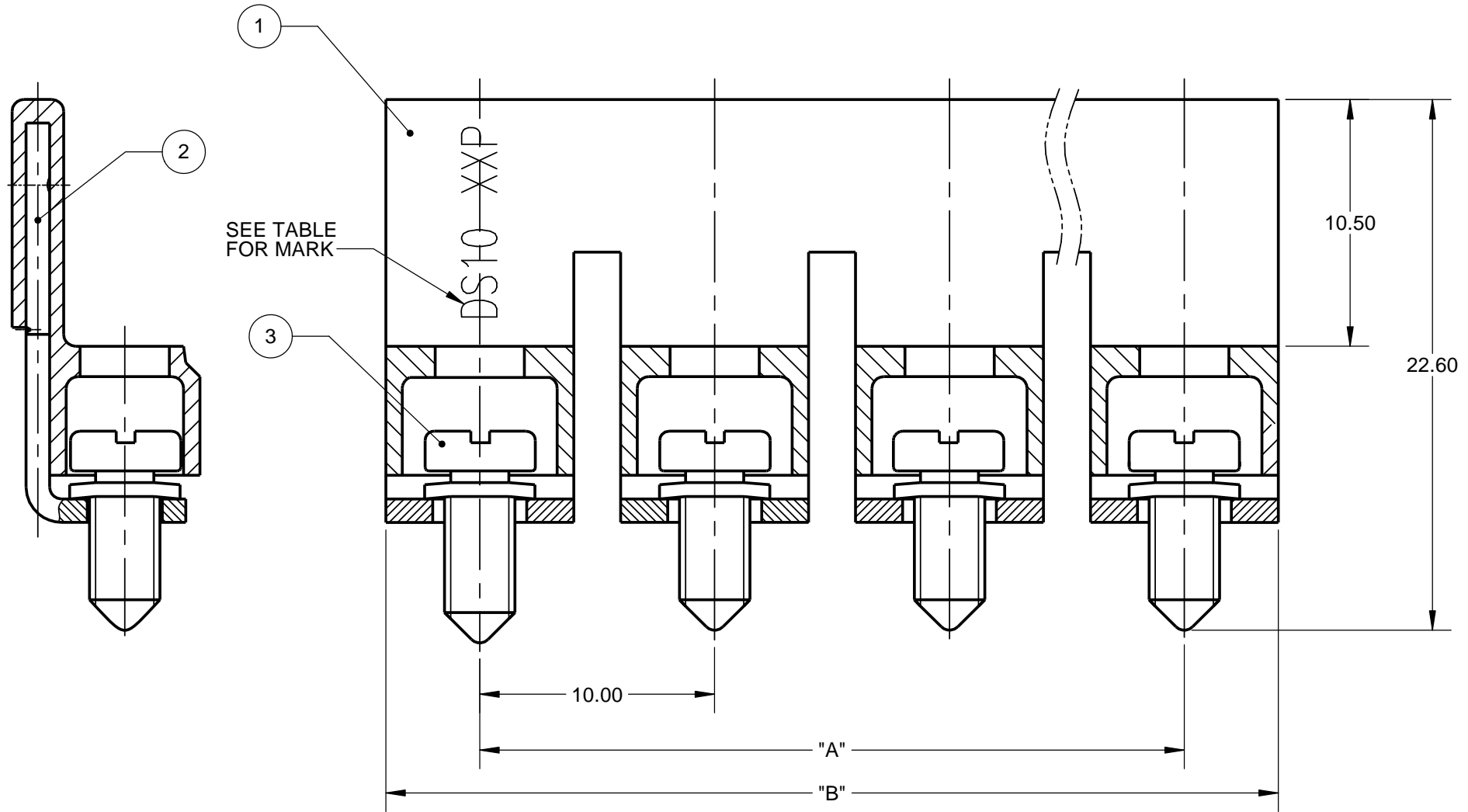
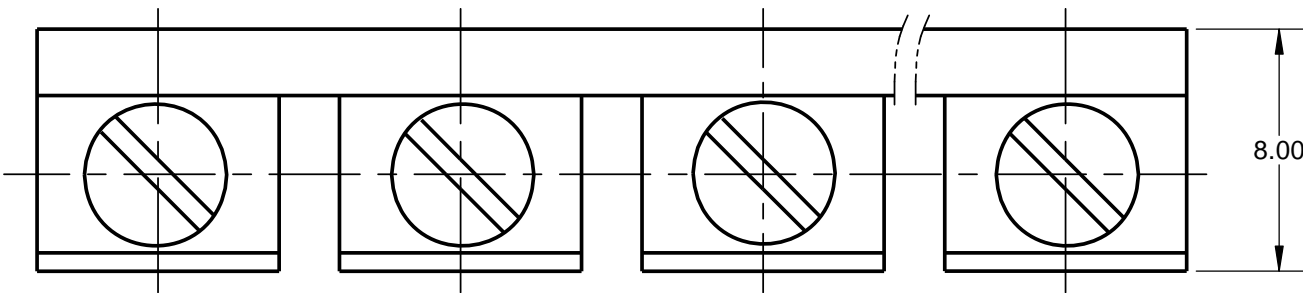

- NOTES:
- RATINGS: 600V/60A  
PITCH: 10.0MM  
INSULATION WITHSTAND VOLTAGE 1500VAC/1MINUTE  
TEMPERATURE RANGE -40°C~105°C
  - SCREW TORQUE 0.8N-M (6.9IN-LB)
  - ASSEMBLY MUST BE FREE OF OIL, GREASE AND OTHER FOREIGN MATERIALS.
  - ASSEMBLY MUST COMPLY WITH RoHS SPECIFICATION #1P2163.

MODEL SOURCE DATA --	MODEL VERSION --	GENERAL DRAWING PRACTICES IN ACCORDANCE WITH ASME - Y14.100-2004 DIMENSIONS AND TOLERANCES IN ACCORDANCE WITH ASME - Y14.5M-1994	APPROVALS ENGINEER: TJN DRAWN: TJN MANUFACTURING ENGINEER: -- MATERIAL: SEE TABLE FINISH: SEE TABLE	DATE 09/26/2012 09/26/2012 --/--/----	 St. Louis, MO 63178 (USA)
THIS DRAWING IS AN UNCONTROLLED COPY IF PRINTED OR SENT ELECTRONICALLY. DO NOT SCALE DRAWING		UNLESS OTHERWISE SPECIFIED DIMENSIONS ARE IN MILLIMETERS TOLERANCES TO BE ONE PLACE X.X = ±0.3mm TWO PLACE X.X X = ±0.13mm ALL ANGLES X.X = ±1°	TITLE <b>SCREW ON BRIDGE</b>		
CONFIDENTIAL. THE INFORMATION CONTAINED IN THIS DOCUMENT IS THE PROPERTY OF COOPER INDUSTRIES, INC. IT IS NOT FOR PUBLIC DISCLOSURE. POSSESSION OF THE INFORMATION DOES NOT CONVEY ANY RIGHT TO LOAN, SELL, OR DISCLOSE THE INFORMATION. UNAUTHORIZED REPRODUCTION OR USE OF THE INFORMATION IS PROHIBITED. THIS DOCUMENT IS TO BE RETURNED TO COOPER INDUSTRIES, INC. UPON COMPLETION OF THE PURPOSE FOR WHICH IT WAS LOANED OR UPON REQUEST.		SPECIAL CHARACTERISTIC $\diamond (0)$ SIGNIFICANT CHARACTERISTIC $\triangle (0)$	SIZE <b>A3</b>		REV <b>A</b>
COPYRIGHT. COOPER INDUSTRIES, INC. THIS IS AN UNPUBLISHED WORK. THE DISCLOSURE OF THIS WORK IS LIMITED TO SELECT PERSONNEL. FURTHER DISSEMINATION OR DISCLOSURE TO THE PUBLIC IS PROHIBITED. THIS UNPUBLISHED WORK IS PROTECTED BY FEDERAL COPYRIGHT LAW AND ALL RIGHTS THEREUNDER ARE RESERVED BY COOPER INDUSTRIES, INC.		THIRD ANGLE PROJECTION	SCALE: 4:1		SHEET 1 OF 1