

2017 NEC® Code changes

**BUSSMANN**  
SERIES

AVAILABLE  
FAULT: 65KA  
SCCR: 5KA

**Code changes affecting  
Short-Circuit Current Ratings  
based on the 2017 NEC®**

**EATON**

*Powering Business Worldwide*

# Table of contents

<b>Subject</b>	<b>Topic</b>	<b>Page</b>
<b>Overview</b>	<b>About this publication</b>	<b>3</b>
<b>Introduction</b>	<b>The NEC and short-circuit current ratings</b>	<b>4-7</b>
<b>Code sections</b>		<b>8-19</b>
• <b>Article 110</b>	<b>Requirements for Electrical Installations</b>	<b>8</b>
• 110.24(A)	Service equipment: document maximum available fault current calculation	8
• <b>Chapter 4</b>	<b>Equipment for General Use</b>	<b>9-13</b>
• 409.22	Industrial control panel: document available short-circuit current calculation	9
• 430.99	Motor control center: document available short-circuit current calculation	10
• 430.130(A)	Adjustable speed drives: when high speed fuses and motor circuit protectors used	11-12
• 440.4(B)	Air-conditioning and refrigeration equipment: marking SCCR for 60 amps or less equipment	13
• 440.10	Air-conditioning and refrigeration equipment: document available short-circuit current calculation and do not install if SCCR is less than available short-circuit current	13
• <b>Chapter 6</b>	<b>Special Equipment</b>	<b>14-15</b>
• 620.16	Elevator control panels: mark with SCCR and do not install if SCCR is less than available short-circuit current	14
• 620.51(D)(2)	Elevator control panels: field mark available short-circuit current	14
• 670.5	Industrial Control Panels: field mark available short-circuit current	15
• <b>Chapter 7</b>	<b>Special Conditions</b>	<b>16-19</b>
• 700.5(E)	Emergency systems: field mark SCCR on transfer equipment exterior	16-17
• 701.5(D)	Legally required standby systems: field mark SCCR on transfer equipment exterior	18
• 702.5	Optional standby systems: field mark SCCR on transfer equipment exterior	18
• 708.24(E)	Critical operations power systems: field mark SCCR on transfer equipment exterior	19
<b>Annex sections</b>		<b>20-27</b>
• Annex 1	Practical approaches to determining available short-circuit current	20
• Annex 2	Best practices for SCCR requirements during various project stages	21
• Annex 3	Product solutions to adjustable speed drive short-circuit protection	22
• Annex 4	Bussmann series resources to help achieve SCCR compliance	23-25
• Annex 5	Bussmann series products to help achieve SCCR compliance	26-27

Notice  
 This publication has not been processed in accordance with NFPA® Regulations Governing Committee Projects. As such, it is not to be construed as an official posting of the NFPA or any of its committees, nor relied upon as a formal interpretation of the meaning or intent of any section of the 2017 edition of the NFPA 70 National Electrical Code (NEC®).

The reader is expressly warned to consider and adopt all safety precautions that might be indicated by the activities described herein and to avoid all potential hazards. By following directions in this publication, the reader willingly assumes all risks in connection with such directions.

Bussmann Division makes no representation of any kind, including but not limited to, the representation of fitness for particular purpose or merchantability, nor are any such representations implied with respect to the presented material. Eaton's Bussmann Division shall not be liable for any special, consequential, or exemplary damages resulting, in whole or in part, from the reader's use of, or reliance upon, this material.

Please refer to the NFPA 70 2017 NEC for complete information on the sections referenced in this publication.

Some photographs used in this publication were shot *in situ*. Use of these photographs does not imply endorsement by Eaton's Bussmann Division of the depicted manufacturers' products.

This publication conveys information related to each of the Code changes it contains as of August, 2016, but does not reflect any subsequent appeal or action taken by the NFPA Standards Council.

©2016  
 Eaton's Bussmann Division  
 All rights reserved. No part of this work may be reproduced in whole or in part, in any graphic, electronic, or mechanical, including photocopying, audio or video recording form, or information storage and retrieval systems without the expressed written permission of the Bussmann Division.

# Overview

## Scope

The scope of this publication is limited to the most significant chapters, articles and parts of the 2017 NEC dealing with available short-circuit current and Short-Circuit Current Ratings (SCCRs).

## The introduction

To provide the reader a frame of reference, the introduction is an in-depth review of this subject covering:

- Why SCCR is important.
- The hazards posed by insufficient SCCR.
- What a Short-Circuit Current Rating is.
- How to comply with NEC SCCR requirements.
- The Occupational Safety and Health Administration's standing on SCCR.
- How equipment SCCR markings are determined.
- Compliance with 110.10.
- The various articles with SCCR requirements relating to 110.10.
- Equipment types requiring SCCR markings, requirements for field marking or documentation of available short-circuit current and specific restrictions on installations.
- Practical considerations for SCCR compliance.

## Significant Code changes

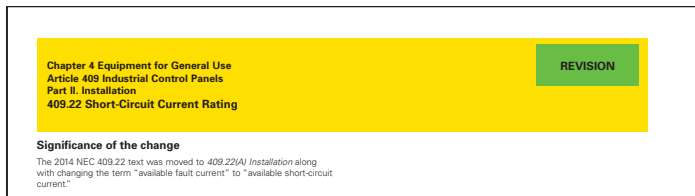

The NEC sections are identified at the top of each page specifying exactly where in the NEC they are to be found.

Next, this publication covers the significant sections of the 2017 NEC changes dealing with SCCR (revisions to existing sections or the addition of new sections).

They are presented in their order of appearance in the NEC.

Each code section is noted as being a "REVISION" or "NEW" followed by an explanation on its significance, related NEC sections, what to look for to determine if there is Code compliance, and, if appropriate, a more detailed explanation of agency standards or equipment markings that impact short-circuit current ratings.

## Annexes

Following the Code changes are annexes containing associated information, resources and products available from Eaton's Bussmann Division that help equipment designers, Authorities Having Jurisdiction (AHJs) and others involved in the specification, design, installation and approval of equipment subject to the 2017 NEC SCCR requirements covered in this handbook.

These resources are available online at no cost\* and are provided to help advance electrical safety and Code compliance.

\* Bussmann series OSCAR™ 2.1 Online Compliance Software is available as a 7-day free trial or a yearly subscription. See OSCAR 2.1 for details.

## NFPA Codes and Standards

Eaton's Bussmann Division recommends referencing the 2017 NEC for complete and detailed code requirements.

All NFPA Codes and standards are available online in a read-only format (not available to print or search). To view the read-only version of the Codes and standards, perform the following:



- Go to [www.nfpa.org](http://www.nfpa.org).
- In the header, roll over "CODES & STANDARDS."
- Click "List of NFPA codes and standards."

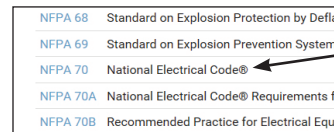

- Scroll down and click on "NFPA 70."

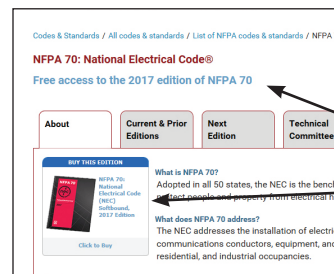

- Click on "Free access to the 2017 edition of NFPA 70"
- To buy the 2017 NEC, click on the "BUY THIS EDITION" link.

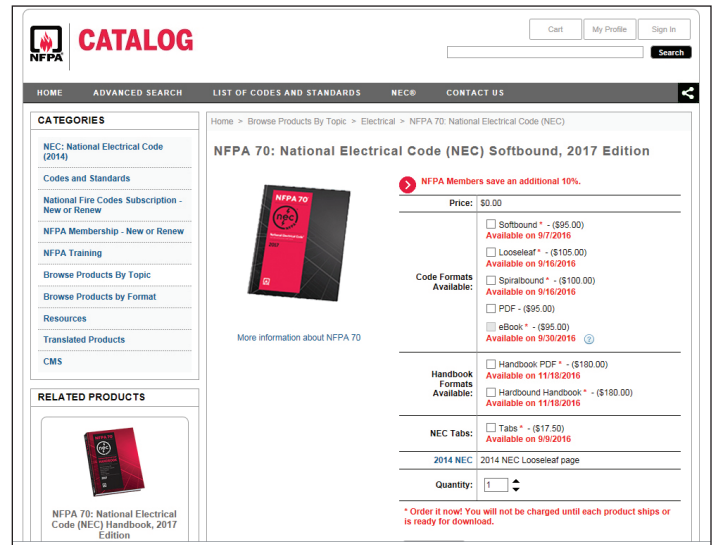

- This will bring up a page where you may specify the desired formats and transact your purchase.



# Introduction

## The NEC and Short-Circuit Current Ratings

This section covers the intent and general discussion of SCCR requirements, followed by the specific 2017 NEC SCCR requirement changes.

SCCR is an equipment rating pertaining to safety under fault current conditions. Failure to apply equipment SCCRs properly can result in serious safety hazards.

### Why is SCCR important?

It's about safety. Both the NEC and OSHA requirements for SCCR prohibit having any equipment located at a point in an electrical system where the available short-circuit current is greater than what the equipment can withstand. This applies to installations of new equipment, as well as equipment that's moved around within a single or multiple facilities.

### What are the hazards of insufficient SCCR?

The hazards are external to the equipment enclosure since equipment SCCR testing and evaluation criteria for product standards is most often performed with the enclosure doors closed and latched, and the fault occurring external to the enclosure. Installing electrical equipment where its SCCR is less than the available short-circuit current creates serious safety hazards. These may include:

- **Shock:** The enclosure becomes energized from conductors pulling out of their terminations or device destruction occurring within the enclosure.
- **Fire:** The explosive power of the internal devices failing causes the closed and latched door to become ajar and spew flame and molten metal to the exterior. This is a fire hazard to both the facility and personnel.
- **Projectile (shrapnel):** The enclosure door may blow open or off with fire and failing device debris (shrapnel) shooting out. In laboratory tests, equipment SCCR failures have resulted in enclosure doors explosively blowing off and flying up to 100 feet away. Additionally, the shrapnel, from the rapid failure of internal devices, can be ejected at speeds up to 700 miles per hour.

### Inadequate SCCR demonstration



Before



During



After



Scan to view video

Scan this QR code to see an actual equipment SCCR test and the consequences of having an equipment SCCR that is too low.

**Note:** Even if electrical equipment is installed with the proper SCCR, there may remain shock, arc flash, and arc blast hazards for workers performing work on energized equipment with the enclosure door open.

### What is Short-Circuit Current Rating?

The NEC Article 100 defines SCCR as:

**Short-Circuit Current Rating.** *The prospective symmetrical fault current at a nominal voltage to which an apparatus or system is able to be connected without sustaining damage exceeding defined acceptable criteria.*

SCCR may be an attribute of a single electrical device, such as a contactor, or of an electrical apparatus which has multiple devices in an enclosure, such as an industrial control panel. An OCPD that is specified to help an apparatus or device achieve an SCCR may either be integral to the apparatus, such as the main OCPD for an industrial control panel, as in Figure 1A, or it may be on the lineside of the apparatus, physically separate, as in Figure 1B.

SCCR is very different from the interrupting rating of an overcurrent protective device (OCPD) which is defined by the NEC in Article 100 as:

**Interrupting Rating.** *The highest current at rated voltage that a device is identified to interrupt under standard test conditions.*

The interrupting rating of a circuit breaker or fuse is an overcurrent protective device (OCPD) self-protection rating. This rating by itself does not ensure loadside electrical equipment will be provided with adequate short-circuit current protection.

The general NEC equipment short-circuit current protection requirement is in 110.10:

**110.10 Circuit Impedance, Short-Circuit Current Ratings, and Other Characteristics.** *The overcurrent protective devices, the total impedance, the equipment short-circuit current ratings, and other characteristics of the circuit to be protected shall be selected and coordinated to permit the circuit protective devices used to clear a fault to do so without extensive damage to the electrical equipment of the circuit. This fault shall be assumed to be either between two or more of the circuit conductors or between any circuit conductor and the equipment grounding conductor(s) permitted in 250.118. Listed equipment applied in accordance with their listing shall be considered to meet the requirements of this section.*

110.10 is in Chapter 1 General, and it applies to all electrical installations unless supplemented or modified in Chapters 1 through 7 (see NEC 90.3). This fundamental NEC requirement exists to ensure electrical equipment is provided with protection under short-circuit current conditions.

Compliance with equipment short-circuit current protection (110.10) is an analysis much different than compliance with overcurrent protective device interrupting ratings (110.9). 110.10 requires all electrical equipment be provided with adequate short-circuit current protection.

The intent of 110.10 is that the equipment and OCPDs must be "selected and coordinated" so that under fault conditions up to the available short-circuit current value, the equipment will not sustain extensive damage. It is the ability of the equipment to withstand a certain magnitude of short-circuit current at a specific voltage in conjunction with an OCPD(s) without becoming a shock, fire, or projectile hazard external to its enclosure.



# Introduction

## The NEC and Short-Circuit Current Ratings

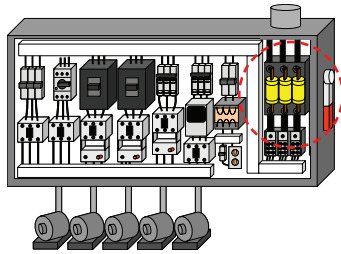

Figure 1A. Main overcurrent protective device is a part of the equipment.

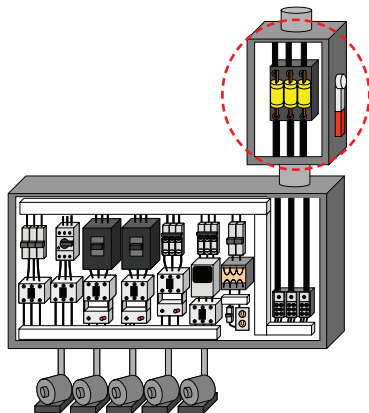

Figure 1B. Overcurrent protective device is not part of the equipment and located on the lineside.

Depending on the equipment type, there may be various means for determining whether equipment is provided adequate short-circuit protection in accordance with 110.10. These include:

- **Analysis methods.** There are analysis methods for some types of devices and apparatus. An example for industrial control panels is the analysis method in *UL 508A Industrial Control Panel* product standard, Supplement SB.
- **Short-circuit current testing in a high power laboratory.** Most products that are marked with an SCCR and are listed to a UL product standard utilize this method in conjunction with criteria to evaluate acceptable damage.
- **Device default short-circuit current ratings.** In some cases, for lower magnitude SCCRs, a product is assumed to have a default SCCR. For instance, *UL 508A Industrial Control Panel* product standard, Supplement SB, Table SB4.1 has default SCCR values for various devices.

NEC 110.10 does not require equipment to be marked with its SCCR. However, there are several NEC requirements for various equipment types that do require SCCR marking. These other NEC requirements complement the 110.10 requirement. Requiring equipment to be marked with its SCCR greatly simplifies the equipment short-circuit current protection compliance process. To comply, the equipment SCCR simply must be equal to or greater than the available short-circuit current.

In addition to the NEC, Underwriters Laboratories (UL®) product standards have safety evaluation criteria and SCCR marking requirements for much of the equipment used in low voltage electrical systems. The safety evaluation criteria concerns shock, fire, and projectile hazards external to the enclosure. The testing procedures typically require the enclosure doors to be closed and latched and they must remain closed and not become deformed, nor allow fire, molten melt, or projectiles to escape the enclosure during the test. Within the enclosure, some degree of damage to devices is normally permitted; devices may need to be repaired or replaced.

### Marked SCCR

With listed equipment, compliance with 110.10 corresponds to the meaning of its last sentence “...Listed equipment applied in accordance with their listing shall be considered to meet the requirements of this section.” If the equipment is listed to a product standard that requires its SCCR to be marked, and if the installation complies with the equipment SCCR marking, then the installation complies with 110.10.

Additionally, 110.3(B) requires the equipment to be installed in accordance with instructions included in the listing or labeling.

This means, that for both 110.10 and 110.3(B), the marked equipment SCCR in amps must be equal to or greater than the available short-circuit current along with SCCR voltage equal to or greater than the nominal system voltage.

In addition, if the equipment SCCR is conditional on a specific OCPD amp rating or specific type OCPD, the proper overcurrent protective device must be used. It is common that some electrical equipment types may have multiple SCCRs that are conditional. The conditions are typically based on the OCPD(s) and magnitude of SCCR in amps. See Figure 2 which is a power distribution block label that shows several different conditional SCCRs.



(1) AWG wire range	(2) Class J fuse max amps	(3) Resulting SCCR
2-6 AWG	400	200 kA
2-14 AWG	200	50 kA
2-14 AWG	175	100 kA

SCCR: When using (1) gauge wire protected by a (2) ampere maximum Class J fuse. This power distribution block is rated for use on a circuit capable of delivering not more than (3) kA rms sym. Or dc amperes 600V maximum. Otherwise 10 kA. Other SCCR options see data sheet.

Figure 2. SCCR varies and depends upon the upstream overcurrent protective device type, amp rating and conductor size.

In Figure 2, this PDB has a default SCCR of 10 kA per UL 508A SB4 Table SB4.1. However, it has also been combination tested and UL Listed with higher SCCRs when in combination with specific current-limiting fuse types and maximum amp ratings. For example, the label is marked with a 200 kA SCCR when protected by 400 A or less Class J fuses and the conductors on the lineside and loadside are in the range of 2 to 6 AWG.

When apparatus are SCCR marked, there are two types of markings:

1. The main OCPD is part of the equipment (see Figure 1A). In this case, the equipment manufacturer includes the OCPD in the equipment and the SCCR marking states the SCCR rms symmetrical amperage and voltage.
2. The equipment does not have a main OCPD and it relies on a field installed OCPD device on the lineside (see Figure 1B). In this case, the SCCR marking states the SCCR rms symmetrical amperage, voltage, and required OCPD type, and amp rating (often stated as a maximum). For example, the SCCR marking may state “100 kA rms symmetrical, 480 V, and maximum 400 A Class J fuse.” This requires 400 amp or less Class J fuses to be field installed on the equipment's lineside in order to comply with the SCCR marking.

**Note:** When the NEC requires an SCCR marking and the equipment is not listed to a product standard, the manufacturer may be able to use an industry method to determine its SCCR. One way to establish the SCCR is to have the equipment tested in a laboratory. For industrial control panels, *UL 508A Industrial Control Panel* product standard in Supplemental SB Short-Circuit Current Ratings for Industrial Control Panels, is an industry analysis method.

# Introduction

## The NEC and Short-Circuit Current Ratings

### Complying with 110.10 is relatively simple

#### 1. Determine the available short-circuit currents.

Take into account future electrical system changes or equipment moves that may result in higher available short-circuit currents. Moving equipment within a facility or to another facility may result in the inability to install the equipment because the SCCR is inadequate for the new location's available short-circuit current.

#### 2. When specifying and ordering electrical equipment, communicate the required SCCR levels.

Equipment builders should require the purchaser to specify the minimum acceptable SCCR level for each piece of equipment. Those who specify or order equipment need to know the available short-circuit currents at the planned installation sites and must communicate to the equipment builders the required minimum SCCR for each piece of equipment. Equipment with SCCRs that exceed the available short-circuit current is recommended as a safety factor, while providing flexibility for system changes and equipment moves. However, equipment SCCR that is not at least equal to the available short-circuit current is a safety hazard and a Code and OSHA violation.

#### 3. Do not install equipment if its SCCR is not equal to or greater than the available short-circuit current.

The installer should not install equipment with an SCCR lower than the available short-circuit current. Free tools exist that make it easy to calculate available short-circuit currents when an available short-circuit current is not marked at the equipment's location. This is similar to working with enclosures; an installer would not install a Type 1 enclosure outdoors where a Type 3R is required.

#### 4. Before energizing any equipment, the Authority Having Jurisdiction (AHJ) should verify the equipment SCCR is equal to or greater than the available short-circuit current.

The AHJ must ensure the equipment has an SCCR equal to or greater than the available short-circuit current. See the information note for the definition of Authority Having Jurisdiction in NEC Article 100.

### The NEC emphasis on proper installation for equipment SCCR

There are several requirements within the NEC that complement the general 110.10 equipment short-circuit current protection requirement. Most of these complementary requirements pertain to specific types of apparatus that have multiple devices within an enclosure and simplify the compliance process.

Table 1 shows some of these requirements in three groupings.

From design to energizing, each industry discipline in the process has their own responsibility for ensuring compliance to equipment short-circuit current protection. Unfortunately, too often equipment is being ordered, installed, and energized with an inadequate SCCR. To help prevent this from occurring, the AHJs, who are responsible for verifying compliance to a safe installation, need tools and procedures to simplify enforcement of NEC SCCR requirements.

The NEC requirements in Tables 1 and 2 help simplify and improve the process for the AHJ. During the development of the 2017 NEC SCCR changes, the Public Inputs and Committee Statement substantiations mention that these requirements are intended to make it simpler and easier for the inspectors/AHJs to ensure compliance.

- First Revision No. 3002 (what eventually became 409.22(B) in the Second Revision): "This change provides much needed information to aid the electrical inspector when enforcing 409.22. It will help the inspector ensure that the industrial control panel is installed within its short-circuit current rating."
- First Revision No. 3006 (440.10): "Inspectors are having an extremely difficult time enforcing proper short-circuit current ratings of HVACR equipment because there is typically no information on the job site as to the available fault current at the HVACR equipment."

*If documentation of the available fault current were provided to the electrical inspector, it would be much easier for the inspector to assure that the equipment was being properly protected. This change provides that fault current information to the AHJ."*

- First Revision No. 3016 (430.99): "... If documentation of the available short-circuit current were provided to the electrical inspector, it would be much easier for the inspector to assure that the equipment was being properly protected."

**Table 1. NEC SCCR requirements that complement 110.10'**

(Red italic text indicates 2017 NEC change)

NEC section	Subject/equipment type
<b>Marking Short-Circuit Current Rating (SCCR)</b>	
409.110(4)	Industrial control panels
430.8	Motor controllers
430.98	Motor control centers
<i>440.4(B)</i>	<i>Air conditioning and refrigeration equipment<sup>2</sup></i>
<i>620.16(A)</i>	<i>Elevator control panel</i>
670.3(A)(4)	Industrial machinery
<i>700.5(E)</i>	<i>Equipment transfer switches for emergency systems<sup>3</sup></i>
<i>701.5(D)</i>	<i>Equipment transfer switches for legally required standby systems<sup>3</sup></i>
<i>702.5</i>	<i>Equipment transfer switches for optional standby systems<sup>3</sup></i>
<i>708.24(E)</i>	<i>Equipment transfer switches for critical operations power systems<sup>3</sup></i>
<b>Marking and/or documenting available short-circuit current</b>	
<i>110.24</i>	<i>Service entrance equipment (mark and document)</i>
<i>409.22(B)</i>	<i>Industrial control panels (document)</i>
<i>430.99</i>	<i>Motor control centers (document)</i>
<i>440.10(B)</i>	<i>Air conditioning and refrigeration equipment (document)</i>
<i>620.51(D)(2)</i>	<i>Elevator control panels (mark)</i>
<i>670.5(2)</i>	<i>Industrial machinery (mark)</i>
<b>Equipment installation: SCCR must be equal to or greater than available short-circuit current</b>	
110.10	Circuit impedance, short-circuit current rating, and other characteristics
<i>409.22(A)</i>	<i>Industrial control panels</i>
<i>440.10(A)</i>	<i>Air conditioning and refrigeration equipment</i>
<i>620.16(B)</i>	<i>Elevator control panel</i>
<i>670.5(1)</i>	<i>Industrial machinery</i>

- 1 This is a high level summary. Reference the 2017 NEC for complete requirements and exceptions.
- 2 440.4(B) revised to eliminate the SCCR marking exemption for 60 amp or less equipment.
- 3 Requires field marking SCCR on the transfer equipment's enclosure exterior. See detailed discussion for each requirement in this publication.

# Introduction

## The NEC and Short-Circuit Current Ratings

**Table 2. NEC requirements (2017 NEC change in red italic text)<sup>1</sup>**

<b>Equipment type</b>	<b>Mark SCCR</b> - UL product standard SCCR marking required - OEM responsibility unless noted as field marked	<b>Available short-circuit current variances</b> - Field mark and/or document/date calculation of available short-circuit current - Make available to inspector (AHJ)	<b>SCCR must be greater than available short-circuit current</b> - Not permitted to install equipment if SCCR is less than the available short-circuit current - Essentially 110.10 and 110.3(B) requirement
Service entrance equipment	- UL 67 Panelboards - UL 891 Switchboards - UL 1558 Switchgear	- 110.24 - Field mark <i>- Document</i>	- 110.10
Industrial control panel	- 409.110(4) - UL 508A	<i>- 409.22(B)</i> <i>- Document</i>	<i>- 409.22(A)</i>
Motor controller	- 430.8 - UL 508 - UL 508C - UL 61800-5-1	—	- 110.10
Adjustable speed drive (circuits with power conversion equipment)	<i>- 430.130(A)(4)<sup>2</sup></i> - UL 508C - UL 61800-5-1	—	- 110.10
Motor control center	- 430.98 - UL 845	<i>- 430.99</i> <i>- Document</i>	- 110.10
Air conditioning and refrigeration equipment	<i>- 440.4(B)<sup>3</sup></i> - UL 1995 - UL 508A	<i>- 440.10(B)</i> <i>- Document</i>	<i>- 440.10(A)</i>
Elevator control panel	<i>- 620.16(A)</i> <i>- UL 508A</i>	<i>- 620.51(D)(2)</i> <i>- Field mark</i>	<i>- 620.16(B)</i>
Industrial machinery	- 670.3(A)(4) - NFPA 79 - UL 508A	<i>- 670.5(2)</i> <i>- Field mark</i>	<i>- 670.5(1)</i>
Transfer equipment in emergency systems	<i>- 700.5(E)</i> <i>- Field mark<sup>4</sup></i> - UL 1008	—	- 110.10
Transfer equipment in legally required standby systems	<i>- 701.5(D)</i> <i>- Field mark<sup>4</sup></i> - UL 1008	—	- 110.10
Transfer equipment in optional standby systems	<i>- 702.5</i> <i>- Field mark<sup>4</sup></i> - UL 1008 - UL 67 - UL 98	—	- 110.10
Transfer equipment in critical operations power systems	<i>- 708.24</i> <i>- Field mark<sup>4</sup></i> - UL 1008	—	- 110.10

1. This is a high level summary. Reference the 2017 NEC for complete requirements and exceptions.
2. The 430.130(A)(4) requirement pertains to listed adjustable speed drives. UL 508C and UL 61800-5-1 require when high speed fuses or MCPs are used in lieu of branch circuit overcurrent protective devices, the adjustable speed drive must be marked with the specific fuse manufacturer and its high speed fuse model number or MCP manufacturer and its MCP model number. For more information on this requirement, see the in-depth discussion under 430.130(A) in this publication.
3. 440.4(B) has been revised to eliminate the SCCR marking exemption for 60 amp or less equipment.
4. These sections require field marking SCCR on the transfer equipment's enclosure exterior. See detailed discussion for each requirement in this publication.

### More information

For expanded information and in-depth discussion on SCCR as well as resources and products that help achieve high equipment SCCRs, see the following annexes in the back of this publication

<b>Annex number</b>	<b>Subject</b>	<b>Page</b>
1	Practical approaches to determining available short-circuit current	20
2	Best practices for SCCR requirements during various project stages	21
3	Product solutions for adjustable speed drive short-circuit protection	22
4	Bussmann series resources to help achieve SCCR compliance	23-25
5	Bussmann series products to help achieve SCCR compliance	26-27



**Significance of the change**

This change requires documentation for the maximum available short-circuit current calculation be available to those authorized to design, install, inspect, maintain or operate the system.

Section 110.24(B) continues to require service equipment to be field marked with the available short-circuit current along with the date the calculation was performed. This does not apply to dwelling units and some industrial installations. 110.24(B) requires the marking to be updated whenever system modifications are made that result in changes to the available short-circuit current.

The intent of this marking is to:

- 1 Help ensure that the service equipment is purchased and installed with short-circuit current rating (SCCR) and overcurrent protective device (OCPD) interrupting ratings equal to or greater than the available short-circuit current.
- 2 This information simplifies the process for the AHJ to verify compliance with OCPD interrupting ratings (110.9) and electrical equipment SCCR (110.10).

**Methods to simplify compliance**

The available short-circuit current can be conservatively calculated using infinite available short-circuit current on the service transformer primary or omitting the service conductor impedance.

A common cause for an increase in available short-circuit current is the utility changing the service transformer. If the transformer has a larger kVA rating and/or lower percentage impedance, the available short-circuit current can significantly increase.

Typically, the service equipment SCCR is primarily dependent upon the overcurrent protective devices' interrupting ratings.

Circuit breaker interrupting ratings vary, based upon the applied voltage, and range from 5 kA to 200 kA.

Current-limiting fuses commonly have interrupting ratings of 200 kA or 300 kA.

By using OCPDs with a high interrupting rating — whether fuses or circuit breakers — facility owners may not get surprised with a safety issue if the utility replaces the service transformer and the available short-circuit current substantially increases.



EATON BUSSMANN SERIES		FC <sup>2</sup> available fault current calculator	
Project Name:	Corner Mall - Unit 1	Fault Name:	X2
System:	Three-Phase	Avail. Fault Current L-L-L (Amps):	52,509
Voltage L-L (Volts):	480	Calculation Performed On:	Sep 1, 2016 @ 4:53pm
Calculation performed via Eaton's Busmann Series Available Fault Current Calculator v1.3			

EATON BUSSMANN SERIES		FC <sup>2</sup> available fault current calculator	
<b>Your System Details</b>			
Project Name:	Corner Mall - Unit 1	System Type:	Three-Phase
Creator Name:	Bill Powers	Creator Email:	BPowers@electricalsystems.com
Creator Company/Organization:	Electrical Systems	Creator Title/Position:	Engineer
Creation Date:	Sep 1, 2016 @ 5:06pm		
<b>FAULT - X1</b>			
$I_{total\ s.c.\ (L-L-L)}$	12,000 AMPS	$I_{sc\ (L-L)}$	51,305 AMPS
Voltage (L-L)	13,200 V	$I_{sc\ motor\ cont.}$	1,204 AMPS
<b>TRANSFORMER - T1</b>			
KVA	1,000	$I_{total\ s.c.\ (L-L-L)}$	52,509 AMPS
Voltage <sub>secondary</sub>	480	Voltage (L-L)	480 V
%Z	2.20	<b>MOTOR CONTRIBUTION - M1</b>	
%Z TOL	-10% (Max Fault)	MOTOR VOLTAGE	480 V
MOTOR <sub>F.L.A.</sub> 301 AMPS			
MOTOR CONTRIBUTION 1,204 AMPS			



<b>FAULT - X1</b>	
$I_{total\ s.c.\ (L-L-L)}$	12,000 AMPS
Voltage (L-L)	13,200 V
<b>TRANSFORMER - T1</b>	
KVA	1,000
Voltage <sub>secondary</sub>	480
%Z	2.20
%Z TOL	-10% (Max Fault)
<b>FAULT - X2</b>	
$I_{sc\ (L-L)}$	51,305 AMPS
$I_{sc\ motor\ cont.}$	1,204 AMPS
$I_{total\ s.c.\ (L-L-L)}$	52,509 AMPS
Voltage (L-L)	480 V
<b>MOTOR CONTRIBUTION - M1</b>	
MOTOR VOLTAGE	480 V
MOTOR <sub>F.L.A.</sub>	301 AMPS
MOTOR CONTRIBUTION	1,204 AMPS

Service entrance panel is field marked with the available short-circuit current and documentation is available.

**Related NEC sections**

- 110.9
- 110.10
- 240.86

See pages 4 to 7 for an in-depth SCCR discussion and pages 23 to 25 for resources and 26 to 27 for products.

**What to look for:**

- Service equipment is field marked with maximum available short-circuit current and date calculation was performed as well as the documentation supporting the calculation is provided.
- Service equipment has manufacturer marked SCCR.\*
- SCCR is equal to or greater than the maximum available short-circuit current.\*
- OCPDs have interrupting ratings equal to or greater than the maximum available short-circuit current.\*

\* In some cases service equipment may be marked with an SCCR and in others, the equipment may be marked similar to "The short-circuit current rating of this panelboard is equal to the lowest interrupting rating of any installed circuit breaker or fused switch..."

### Significance of the change

The 2014 NEC 409.22 text was moved to 409.22(A) *Installation* along with changing the term “available fault current” to “available short-circuit current.”

409.22(B) *Documentation* is entirely new. It stipulates any panel required to be marked with its SCCR in accordance 409.110(4) must also have the available short-circuit current calculated and documented, along with the date it was calculated, and made available to those authorized to inspect the installation.

409.22 does not apply to industrial control panels that contain only control circuit components (not having power circuits) per 409.110(4).

These three requirements work together to make it easier for inspectors to ensure a safer installation:

- 409.110(4) did not change from the 2014 NEC. It still requires the panel builder to mark the equipment short-circuit current rating and it must be “plainly visibly after installation.”
- If the industrial control panel is to be marked with its SCCR, then 409.22(B) now requires the available short-circuit current to be determined. This calculation and the date it was performed must be made available to the inspector or Authority Having Jurisdiction (AHJ).
- 409.22(A) makes it clear that an industrial control panel cannot be installed when its marked short-circuit current rating is less than the available short-circuit current.

In some cases, a designated government inspector may not be involved in an industrial control panel (ICP) installation, such as when an ICP is:

- Installed after the final building inspection.
- Moved within an existing facility or moved to another existing facility.
- An integral part of business process equipment that gets bought or moved after the final government inspection.

Regardless, someone, such as the property owner or his designated representative, is the AHJ with responsibility for verifying the electrical installation complies with the NEC (see NEC Article 100 definition for AHJ including the Informational Note). This includes ensuring an industrial control panel is only installed if its SCCR is equal to or greater than the available short-circuit current.



Manufacturer’s nameplate with equipment SCCR marking appears on the enclosure’s interior.

**Eaton**  
BUSSMANN  
SERIES

FC<sup>2</sup> available fault current calculator

---

**Your System Details**

Project Name: Commercial Plaza  
System Type: Three-Phase  
Creator Name: Arthur H Jones  
Creator Email: AHJ@widgets.com  
Creator Company/Organization: Widgets, Inc.  
Creator Title/Position: Supervisor  
Creation Date: Aug 2, 2016 @ 8:59am

**INFINITE PRIMARY SOURCE**

**TRANSFORMER - T1**

kVA	5,000
Voltage	480
%Z	5.00
%Z TOL	-10% (Max Fault)

**FAULT - X1**

I <sub>sc</sub>	80,180 AMPS
Voltage (L-L)	480 V

Documentation for the available short-circuit current and the date it was performed is available to the inspector.

### Related NEC sections

- 110.10
- 409.110(4)

See pages 4 to 7 for an in-depth SCCR discussion and pages 23 to 25 for resources and 26 to 27 for products.

### What to look for:

- Available short-circuit current and documentation supporting the calculation being provided.
- Industrial control panel SCCR marked on equipment by manufacturer.
- SCCR equal to or greater than the available short-circuit current.

**Chapter 4 Equipment for General Use**  
**Article 430 Motors, Motor Circuits, and Controllers**  
**Part VIII. Motor Control Centers**  
**430.99 Available Fault Current**

**NEW**

**Significance of the addition**

The new NEC section 430.99 requires:

- Calculating the available short-circuit current where a motor control center (MCC) is to be installed.
- The documentation of the available short-circuit current and the date it was calculated must be made available to the inspector or Authority Having Jurisdiction (AHJ).

This new section works in conjunction with the already existing 430.98 that requires an MCC to be marked with its short-circuit current rating. Now, with 430.98 and 430.99 in place, it will be relatively easy for the inspector to determine if an MCC installation is compliant by comparing the MCC SCCR to the available short-circuit current.



Manufacturer's nameplate with equipment SCCR marking.

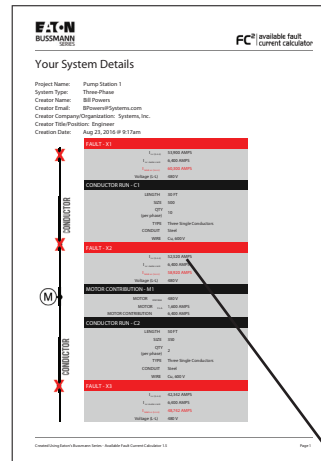

<b>FAULT - X1</b>	
$I_{SC(L-L)}$	53,900 AMPS
$I_{SC, motor cont.}$	6,400 AMPS
$I_{total SC(L-L)}$	<b>60,300 AMPS</b>
Voltage (L-L)	480 V
<b>CONDUCTOR RUN - C1</b>	
LENGTH	30 FT
SIZE	500
QTY (per phase)	10
TYPE	Three Single Conductors
CONDUIT	Steel
WIRE	Cu, 600 V
<b>FAULT - X2</b>	
$I_{SC(L-L)}$	52,520 AMPS
$I_{SC, motor cont.}$	6,400 AMPS
$I_{total SC(L-L)}$	<b>58,920 AMPS</b>
Voltage (L-L)	480 V
<b>MOTOR CONTRIBUTION - M1</b>	
MOTOR VOLTAGE	480 V
MOTOR F.L.A.	1,600 AMPS
MOTOR CONTRIBUTION	6,400 AMPS
<b>CONDUCTOR RUN - C2</b>	
LENGTH	50 FT
SIZE	350
QTY (per phase)	2
TYPE	Three Single Conductors
CONDUIT	Steel
WIRE	Cu, 600 V
<b>FAULT - X3</b>	
$I_{SC(L-L)}$	42,342 AMPS
$I_{SC, motor cont.}$	6,400 AMPS
$I_{total SC(L-L)}$	<b>48,742 AMPS</b>
Voltage (L-L)	480 V

Documentation for available short-circuit current that includes the date the calculation was made.

**Related NEC sections**

- 110.10
- 430.98

See pages 4 to 7 for an in-depth SCCR discussion and pages 23 to 25 for resources and 26 to 27 for products.

**What to look for:**

- Available short-circuit current and documentation supporting the calculation being provided to inspector.
- SCCR marked by motor control center manufacturer.
- SCCR equal to or greater than the available short-circuit current.



**430.130 Branch Circuit Short-Circuit and Ground Fault Protection for Single Motor Circuits Containing Power Conversion Equipment**  
**430.130(A) Circuits Containing Power Conversion Equipment**

**Significance of the change**

This Code change is for listed adjustable speed drive short-circuit current ratings (SCCRs). The applicable UL product standards *UL 508C Standard for Power Conversion Equipment* and *UL 61800-5-1 Standard for Adjustable Speed Electrical Power Drive Systems - Part 5-1: Safety Requirements - Electrical, Thermal and Energy* already have this requirement. The *Protecting power electronics devices requires extra consideration* discussion on this page and Annex 3 provide greater insight into a significant transition occurring for adjustable speed drive SCCR protection.

- This Code change: Where the manufacturer's instructions for their listed power electronic conversion equipment permits semiconductor fuses or instantaneous trip circuit breakers for use as the branch circuit short-circuit and ground fault protective device, they must be integrated in the same assembly.
- Semiconductor fuses are also commonly referred to as high speed fuses and instantaneous trip circuit breakers are commonly referred to as motor circuit protectors or MCPs.
- In addition, when semiconductor fuses or MCPs are used, UL 508C and UL 61800-5-1 require the drives to be marked with the specific fuse manufacturer and fuse model number or MCP manufacturer and MCP model number, plus the marking must state these protective devices must be integrated in the same assembly with the adjustable speed drive controller.
- These extra precautions are necessary since the MCPs and most semiconductor fuses are not branch circuit overcurrent protective devices as defined in Article 100. These application-limited devices are permitted in the NEC to be applied, with restrictions, for this application: see 430.52(C)(3), 430.52(C)(5), and 430.130(A)(4). They are recognized products which require the drive manufacturer to evaluate these specific devices for the specific application.
- Most adjustable speed drives are listed with specific OCPD types. For safety and compliance to 110.3(B), the adjustable speed drive manufacturer's markings and instructions concerning the specific OCPD and corresponding SCCR must be followed.

**Related NEC sections**

- 430.52(C)(3)
- 430.52(C)(5)

See pages 4 to 7 for an in-depth SCCR discussion and pages 23 to 25 for resources and 26 to 27 for products.



**Protecting power electronic conversion equipment requires extra considerations**

The adjustable speed drive product standard is transitioning from UL 508C to UL 61800-5-1 and will result in more stringent short-circuit current testing for enhanced safety. The use of more current-limiting OCPDs and high speed fuses are expected to become more prevalent.

Adjustable speed drives present different short-circuit and ground fault protection challenges compared to the traditional electromechanical motor circuit devices. Typically, adjustable speed drives with Insulated Gate Bipolar Transistors (IGBTs) will shut down quickly for external faults on the adjustable speed drive output. However, drives listed to UL 508C may not have been evaluated for internal faults. The internal fault damage can be catastrophic and result in extensive damage to the drive and adjacent circuits and devices. In some cases, high speed fuses are the only type of OCPDs that provide the high degree of current-limitation necessary for drive internal fault protection. Superior current-limiting protection may minimize drive damage as well as collateral damage to adjacent circuits.

A specific adjustable speed drive model number may have multiple SCCRs conditional on the OCPD type and corresponding SCCR level achieved in the product standard testing evaluation, e.g., a drive may have two SCCR: 5 kA for an OCPD complying with 430.52, and 100 kA when protected by a manufacturer's specific high speed fuse model number. In some cases, an adjustable speed drive may be listed with only one permissible specific OCPD and corresponding SCCR. This information will be marked on the drive and/or noted in the installation instructions.

UL 508C is being phased out as the industry transitions to the new UL 61800-5-1 standard. These product standards pertain to open or enclosed power electronic conversion equipment that supply power to control a motor, or motors, operating at a frequency or voltage different than that of the input supply. One of the benefits is a significant improvement for adjustable speed drive short-circuit current protection.

*Continued on the next page.*

**Chapter 4 Equipment for General Use**  
**Article 430 Motors, Motor Circuits, and Controllers**  
**Part X. Adjustable-Speed Drive Systems**  
**430.130 Branch Circuit Short-Circuit and Ground Fault Protection for Single Motor Circuits**  
**Containing Power Conversion Equipment**  
**430.130(A) Circuits Containing Power Conversion Equipment**

**REVISION**

**Changing UL Standards**

Effective February, 2016, any new adjustable speed drive design must be evaluated to UL 61800-5-1. Effective February, 2020, all adjustable speed drives are required to be evaluated to UL 61800-5-1 and UL 508C

will be withdrawn. Table 4 details three important differences affecting adjustable speed drive overcurrent protection as a result of this change.

**Table 4: Change in UL Standards**

Phasing out UL 508C	Effective February 2020 UL 61800-5-1
Motor output of the drive short-circuit tested.	All drive outputs short-circuit tested.
No specific requirements for the short-circuit testing of adjustable speed drive internal components (breakdown of components testing).	Internal adjustable speed drive components must be tested for both standard and high fault currents based on manufacturer's short-circuit current rating; unless analysis shows a different value is more severe.
Testing with cotton not required during short-circuit and breakdown of components testing with circuit breakers.	Cotton indicator is required for all short-circuit and breakdown of components tests when testing with circuit breakers.

Providing adjustable speed drives with adequate short-circuit protection can be a challenge. Adjustable speed drives listed to UL 61800-5-1 will include the additional (not required in 508C) short-circuit current testing and evaluation criteria for internal drive component failure (breakdown of components).

Without proper overcurrent protection, internal adjustable speed drive components, such as the power electronic devices and capacitors, can fail resulting in short-circuit current damage that may be catastrophic. Extensive damage could occur to the various drive elements and collateral damage could occur as well to adjacent devices and circuits.

UL 61800-5-1 requires testing to simulate internal drive component failures, therefore, the damage to other drive elements or collateral damage to other adjacent circuits will be greatly reduced or contained.

The drive manufacturers are transitioning to the new standard. To meet the requirements for short-circuit and breakdown of components testing, damage to internal drive components must be either contained (by physical means such as more rugged enclosure) or reduced through the use of current-limiting OCPDs. In many cases, traditional branch circuit breakers and some less current-limiting fuses may not be able to provide adequate protection. This may lead to the use of very current-limiting OCPDs with the semiconductor (high speed) fuses being the most current-limiting. The protection requirements can vary based on the horsepower range and typical adjustable speed drive designs in those ranges.

*See Annex 3 for product solutions for adjustable speed drive short-circuit current protection.*

**Chapter 4 Equipment for General Use**  
**Article 440 Air-Conditioning and Refrigeration Equipment**  
**Part I. General**

**440.4 Marking on Hermetic Refrigerant Motor-Compressors and Equipment**  
**440.4(B) Multimotor and Combination-Load Equipment**

**REVISION**

**Significance of the change**

This code change concerns multi-motor and combination-load hermetic refrigeration equipment rated 60 amps or less.

- Previous editions of the NEC exempted this equipments' nameplate from being marked with their short-circuit current rating (SCCR). This exception has been removed.
- Now, this type of equipment must have its short-circuit current rating marked on its nameplate, the same as all other HVAC equipment in 440.4(B).

Marking the nameplate with the short-circuit current rating as required by 440.4(B) ties in with 440.10(A) and 440.10(B).

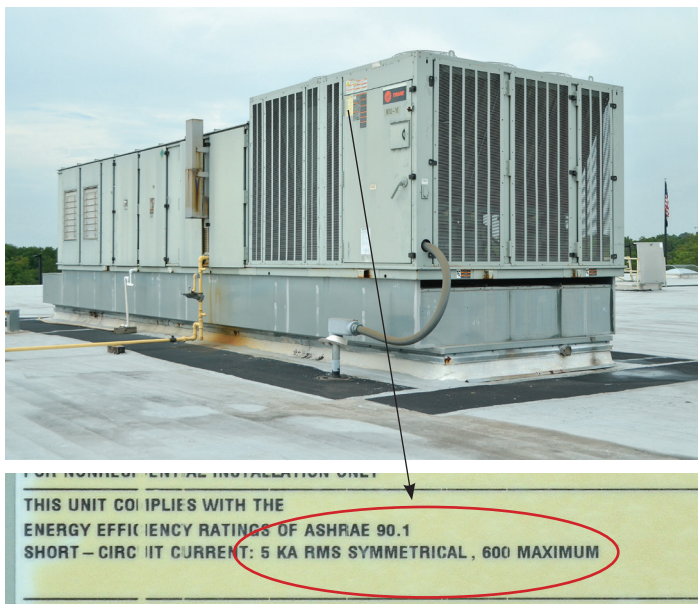

HVAC units cannot be installed where the available short-circuit current is greater than the equipment SCCR. The unit above would be a Code violation if installed at "HVAC Rooftop — North" as summarized in the report shown in Figure 3.

**Related NEC sections**

- 110.10

See pages 4 to 7 for an in-depth SCCR discussion and pages 23 to 25 for resources and 26 to 27 for products.

**440.10 Short-Circuit Current Rating**  
**440.10(A) Installation and 440.10(B) Documentation**

**NEW**

**Significance of the addition**

With a few exceptions, 440.4(B) already requires that air conditioning and refrigeration, multi-motor and combination-load equipment be marked with their SCCR.

If the equipment is required to be marked with an SCCR, now:

- New 440.10(B) — the available short-circuit current must be calculated, documented and made available to the inspector along with the date the calculation was made.
- New 440.10(A) — the equipment shall not be installed if its SCCR is not equal to or greater than the available short-circuit current (see Figure 3).

The specifications provided to the HVAC original equipment manufacturer need to include the minimum required SCCR.

If consulting engineers are involved, coordination between the electrical and mechanical engineering departments should be made so that the specified minimum acceptable equipment SCCR is greater than the available short-circuit current.

<b>Summary of Short-Circuit Current Study for Ernest Operations, Inc., January, 23, 2017</b>	
By Fred Byrd	
The calculations are on the pages following this summary table	
Equipment Designation	Available Short-Circuit Current amps rms sym.
Service Equipment	45,340
Motor Control Center 1	30,600
Motor Control Center 2	26,780
Distribution Panel - North	15,345
Distribution Panel - South	36,070
Industrial Control Panel 1	16,290
HVAC Rooftop — North	13,700
HVAC Rooftop — South	9,980
Panelboard 1	17,460
Panelboard 2	8,440
Panelboard 3	15,050
Panelboard 4	36,745

Figure 3. This report documents the available short-circuit current for HVAC — North. The SCCR must be equal to or greater than the available short-circuit current.

**What to look for:**

- All hermetic refrigerant motor-compressors and equipment subject to 440.4(B) is manufacturer nameplate marked with their SCCR, including equipment rated less than 60 amps.
- Available short-circuit current and documentation is provided to inspector.
- Do not install nor approve equipment installation if the SCCR is less than the available short-circuit current.



## Chapter 6 Special Equipment

### Article 620 Elevators, Dumbwaiters, Escalators, Moving Walks, Platform Lifts, and Stairway Chairlifts

#### Part II. Conductors

##### 620.16 Short-Circuit Current Rating

#### Part VI. Disconnecting Means and Control

##### 620.51 Disconnecting Means

##### 620.51(D)(2) Available Short-Circuit Current Field Marking

#### Significance of the additions

These new requirements make it easier for inspectors to verify elevator control panels have sufficient equipment SCCR for the available short-circuit current.

- 620.16(A) - manufacturers must mark their elevator control panels with an equipment short-circuit current rating (SCCR). The SCCR can be based on an assembly product standard listing and labeling, or an approved analysis method, such as UL 508A, Supplement SB.
- 620.51(D) - An elevator control panel must now be field marked with the maximum available short-circuit current along with the date the calculation was made.
- 620.16(B) - if the SCCR of an elevator control panel is not equal to or greater than the available short-circuit current, the elevator control panel must not be installed.
- With the marked SCCR and marked available short-circuit current on the elevator control panel, an inspector can easily check for compliance.

The person responsible for the specifications or for ordering the elevator controls needs to communicate the minimum elevator control panel SCCR level that is required for a specific installation to the equipment supplier. This requires knowing the available short-circuit current. Elevator control suppliers should require customers to provide the minimum SCCR level as necessary in their specification data.

If there is a change to the available short-circuit current, then 620.51(D)(2) requires revising the field marking. Then the equipment SCCR must be verified that it is not less than this revised available short-circuit current.

Changes to the electrical distribution system can increase the available short-circuit current when a larger kVA or lower percent impedance transformer is installed, or premise wiring changes occur.



Sample Label

**Nidec MCE**

**Model:** SCE-AC-0X    **Date:** 08/25/2016    **Serial #:** 8001424  
**Job #:** XXXXXXXXXX  
**Input:** XXXV rms, 3 Ø, 50/60Hz, XXXA rms  
**Output: Motor:** XXX hp, XXX Vac, X phase, XX.X Hz, XXXXX FLA  
**Brake:** XXXXVdc XXX Amps DC

Suitable for use on a circuit capable of delivering not more than 10,000 rms Symmetrical Amperes, 600 Volts

CONVIENT À CIRCUIT POUVANT DÉBITER UN COURANT DE DÉFAUT MAXIMAL EST DE 10,000 AMPERES EFFICACES SYMÉTRIQUES SOUS UNE TENSION MAXIMALE DE 600 V.

ETL Recognized  
3084676  
CONFORMS TO  
ANSI/ASME STD A17.5  
CERTIFIED TO  
CAN/CSA STD B44.1  
EN 12016 Compliant

46-03-0129 R1 Motion Control Engineering A Nidec Kinetek Company www.nidec-MCE.com MADE IN USA

**EATON**  
BUSSMANN  
SERIES

**FC<sup>2</sup> | available fault current calculator**

Project Name: Office Building A  
 Fault Name: Elevator Tower B  
 System: Three-Phase

Avail. Fault Current L-L (Amps): 9,055

Voltage L-L (Volts): 480  
 Calculation Performed On: Sep 2, 2016 @ 10:20am

Calculation performed via Eaton's Bussmann Series Available Fault Current Calculator v1.5

Elevator control panel has a manufacturer's nameplate SCCR of 10 kA and is field marked with available short-circuit current 9055 A.

Photo courtesy of MCE.

#### What to look for:

- The elevator control panel's manufacturer nameplate is marked with its SCCR.
- The control panel is field marked with the available short-circuit current and documentation supporting the calculation is available.
- If the control panel's SCCR is equal to or greater than the marked available short-circuit current.

#### Related NEC sections

- 110.10

See pages 4 to 7 for an in-depth SCCR discussion and pages 23 to 25 for resources and 26 to 27 for products.

**Significance of the addition**

This new requirement 670.5(2) is related to 670.3(A)(4) and 670.5(1).

- The existing 670.3(A)(4) requires the industrial machinery nameplate to be marked with the equipment short-circuit current rating (SCCR). This nameplate must be plainly visible on the control panel enclosure or machine.
- The new 670.5(2) requires field marking the available short-circuit current and the date the calculation was made. It is advisable to place this label adjacent to the manufacturer's nameplate which has the equipment SCCR marking.
- If the equipment's SCCR is less than the available short-circuit current, 670.5(1) makes it clear that the equipment should not be installed and the Authority Having Jurisdiction (AHJ) shall not approve the installation.

The requirement in 670.5(2) along with the already existing requirements of 670.3(A)(4) and 670.5(1) simplifies the enforcement process for the AHJ.

Some industrial machinery installations do not involve a designated government inspector. Regardless, someone, such as the property owner or a designated agent, assumes the inspection (AHJ) responsibility (see NEC Article 100 definition for AHJ including the Informational Note). The same applies if an industrial machine is moved within a facility or to a different facility and a government inspector is not involved. Enforcing these three requirements — 670.5(2), 670.3(A)(4), and 670.5(1) — are extremely important for preventing fire hazards as well for personnel safety in facilities and around the equipment.

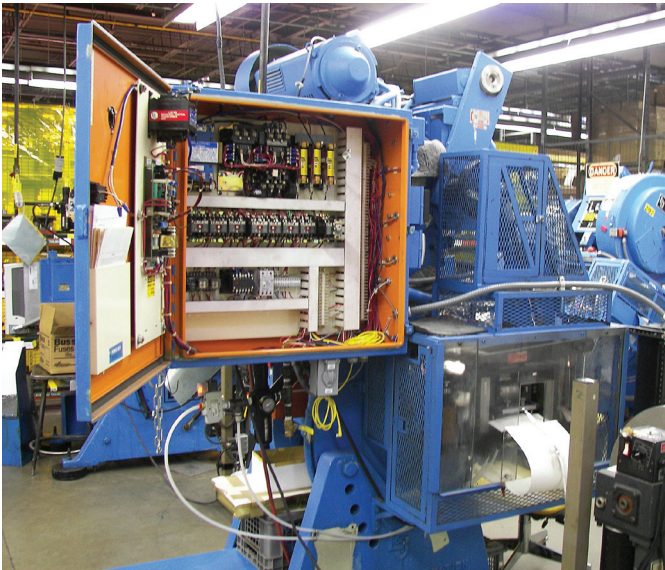

*This machine's industrial control panel has 50 kA SCCR marked on the nameplate inside the enclosure. The available short-circuit current is field marked on the exterior.*

<b>EATON</b> BUSSMANN	<b>FC<sup>2</sup></b> available fault current calculator
Project Name: Press Panels	
Fault Name: Production Line 1	
System: Three-Phase	
Avail. Fault Current	L-L (Amps) : 8,540
Voltage	L-L (Volts) : 480
Calculation Performed On:	Aug 22, 2016 @ 9:01 am
Calculation performed via Eaton's Bussmann Series Available Fault Current Calculator v1.5	

**Related NEC sections**

- 110.10
- 670.3(A)(4)

See pages 4 to 7 for an in-depth SCCR discussion and pages 23 to 25 for resources and 26 to 27 for products.

**What to look for:**

- The nameplate on an industrial machine's control panel or machine itself is plainly marked with its industrial control panel's SCCR.
- An industrial machine is field marked with the available short-circuit current and date of the calculation.
- The industrial machine's industrial control panel SCCR is equal to or greater than the marked available short-circuit current.

### Significance of the addition

The short-circuit current rating (SCCR) for emergency system transfer equipment must be field marked on the equipment's exterior. This addition makes it easier for inspectors to verify that the equipment SCCR is equal to or greater than the available short-circuit current and helps to verify compliance with 110.10.

### Background

An Automatic Transfer Switch (ATS) listed for emergency system use is a key component for switching between the normal and the alternate, emergency power source. ATSs listed to UL 1008 Transfer Switch Equipment are often marked inside the unit with many possible SCCR levels making it difficult for inspectors to decipher them, much less determine which SCCR level applies to a specific installation.

The ATS marked SCCR values can vary based on the voltage and overcurrent protective device (OCPD) type, amp rating, settings and characteristics. The OCPD providing the ATS's SCCR level may be integral to the ATS, but often it's installed on the lineside of the ATS equipment. For a specific installation, it may not be obvious which of many ATS SCCR levels is being utilized and expressed in terms of the SCCR in kA rms symmetrical for the specific installation. This field marking must be affixed to the transfer equipment exterior and will help the inspection process.

For compliance with NEC 110.10, the transfer equipment SCCR must be equal to or greater than the available short-circuit current. To improve the process further, the inspector could also require documentation for the available short-circuit current be provided to verify compliance to NEC 110.3(B) and 110.10.

UL 1008 has unique SCCR nomenclature. The following information expands upon ATS SCCR equipment markings (also see label example on the next page).

### UL 1008 SCCR nomenclature

The SCCR nomenclature used in UL 1008 for marking ATSs that are suitable for emergency systems make use of "short-circuit withstand and closing rating," "short-time current rating," or other similar derivatives. Often, "short-circuit withstand and closing rating" is shortened to "withstand and closing rating" with WCR as its acronym. The WCR is applicable when evaluating the ATS OCPD — either a circuit breaker with an instantaneous trip, even if it also has a short-time-delay, or current-limiting fuses.

The short-time current ratings are applicable when an ATS is being evaluated for protection by circuit breakers with a short-time delay (no instantaneous trip) and the interrupting time is intentionally delayed for a duration such as 0.1, 0.3, or 0.5 second. In some applications, circuit breakers with short-time delays are utilized to achieve selective coordination with downstream circuit breakers. However, when a circuit breaker with intentional short-time delay and no instantaneous trip is protecting an ATS, the ATS must withstand the fault current for the duration of the set time delay. Therefore, the ATS's SCCR for "short-time current rating" is normally lower than the when an ATS is protected by a circuit breaker with instantaneous trip.

### Related NEC sections

- 110.10
- 701.5(D)
- 702.5
- 708.24(E)

See pages 4 to 7 for an in-depth SCCR discussion and pages 23 to 25 for resources and 26 to 27 for products.



**SHORT-CIRCUIT  
CURRENT RATING**  
**200 kA RMS  
SYMMETRICAL**

July 27, 2016

*An example of a short-circuit current rating field marking of emergency system transfer equipment.*

A given ATS may have several SCCR levels that are marked on the equipment by the manufacturer. Figure 4 on the next page illustrates a manufacturer's marking for SCCR with four OCPD categories and comments about usage. In all cases, pay attention to the maximum voltage.

- 1. Specific manufacturer's circuit breaker and type:**  
The circuit breaker manufacturer, type (model number) and amp rating has to be explicitly stated, such as Eaton, CLD, 600 A. Be sure to adhere to the limits of the circuit breaker's voltage rating and interrupting rating.
- 2. Short-circuit current withstand and closing with a circuit breaker:**  
A circuit breaker can be used if it has an instantaneous trip with a maximum clearing time equal to or less than the ATS marked time duration. This includes a circuit breaker that has a short-time delay in addition to an instantaneous trip or instantaneous override. Be sure to adhere to the limits of the circuit breaker's voltage rating and interrupting rating.
- 3. Short-time current ratings with a circuit breaker:**  
Any circuit breaker with a short-time delay (no instantaneous trip) can be used if the circuit breaker short-time delay setting is equal to or less than the ATS marked time duration. Be sure to adhere to the limits of the circuit breaker's voltage rating and withstand rating for short-time delay.
- 4. Short-circuit current withstand and closing with fuses:**  
Fuses of a specific UL fuse class can be used when not exceeding the maximum ampere rating shown in the marking. Be sure to adhere to the limits of the fuse voltage rating. It is common that the fuse interrupting ratings are equal to or greater than the marked SCCR. In most cases, current-limiting fuse protection for ATSs results in a 200 kA WCR (withstand and closing rating). In addition, selective coordination with lineside or loadside fuses is simple if the proper fuses are specified and applied in accordance with published selective coordination fuses amp ratios.

### What to look for:

- Emergency system transfer equipment is field marked on the enclosure exterior with the SCCR from the manufacturer's equipment marking label that corresponds to the specific installation (voltage, OCPD type, amp rating, setting, etc.).
- If the equipment SCCR is equal to or greater than the available short-circuit current.



**Specific Circuit Breaker Manufacturer and Type Listing**

When protected by a circuit breaker of the specific manufacturer type and ampere rating as marked below, this transfer switch is suitable for use in circuits capable of delivering the short-circuit current at the maximum voltage marked.

Short-Circuit Current (RMS Symmetrical amperes X 1000)	Voltage (Volts AC Maximum)	Manufacturer	Type	Rating (Ampere)
65	480	EATON Corp.	CHLD	600
35	480	EATON Corp.	CLD	600
35	600	EATON Corp.	CHLD	600

1. **Specific manufacturer's circuit breaker and type (with instantaneous trip):**  
 The CB manufacturer and type permitted has to be explicitly stated on the SCCR marking.

Example: if an Eaton CHLD 600 A CB is used on a 480 V system, field mark the exterior with "Short-Circuit Current Rating 65 kA rms symmetrical at 480 V."

**Short-Circuit Withstand/Closing and Short-Time Current Rating**

When protected by a circuit breaker, this transfer switch is suitable for use in a circuit capable of delivering the short-circuit current for the maximum time duration and voltage as marked below.

The circuit breaker must include an instantaneous trip response unless the available short-circuit current is less than or equal to the short-time rating of the transfer switch and the circuit breaker includes a short-time response.

The maximum clearing time of the instantaneous trip response must be less than or equal to the time duration shown for the marked short-circuit current.

When protected by a circuit breaker with a short-time trip response, the short-time response of the circuit breaker must be coordinated with the short-time current rating of the transfer switch as marked below.

Short-Circuit Current (RMS Symmetrical amperes X 1000)	Voltage (Volts AC Maximum)	Time Duration (Sec. Maximum)
50	480	0.050
42	600	0.050
35	480	0.067

2. **Short-circuit current withstand and closing with a circuit breaker:**  
 Requires a CB with an instantaneous trip having a maximum interrupting time (verified by the manufacturer's time-current curve) that's equal to or less than the value in the *Time Duration* column.

Example: a 480 V system, if the selected CB has an instantaneous trip which interrupts the short-circuit current in 0.05 or less seconds, then field mark the exterior with "Short-Circuit Current Rating 50 kA rms symmetrical at 480 V."

Short-Time Current (RMS Symmetrical amperes X 1000)	Voltage (Volts AC Maximum)	Time Duration (Sec. Maximum)
20	480	0.5

3. **Short-time current ratings with a circuit breaker:**

Any CB with a short-time delay can be used if the circuit breaker's short-time delay setting is equal to or less time than the marked *Time Duration*.

Example: if using a 600 A trip/800 A frame power CB with a short-time delay set at 0.5 second then field mark the exterior with "Short-Circuit Current Rating 20 kA rms symmetrical at 480 V."

**Short-Circuit Withstand/Closing Rating When Protected by Fuses**

When protected by a fuse of the specific fuse class and maximum ampere rating as marked below, this transfer switch is suitable for use in a circuit capable of delivering the short-circuit current at the maximum voltage marked.

Short-Circuit Current (RMS Symmetrical amperes X 1000)	Voltage (Volts AC Maximum)	Fuse Class	Rating (Ampere)
200	600	J	600
200	600	L	800

4. **Short-circuit current withstand and closing with fuses:**

Fuses of a specific class and not exceeding the maximum ampere rating shown can be used.

Example: if Bussmann series Class J LPJ-600SP fuses (600 A /600 V) are selected, the equipment exterior could be field marked with "Short-Circuit Current Rating 200 kA rms symmetrical at 480 V."

Figure 4. Illustrative ATS label. In most cases, an ATS label has many potential SCCR options and a specific installation utilizes just one.

**Notes:**

- Verify the circuit breakers have adequate interrupting rating or short-time withstand rating and voltage rating. Most current-limiting fuses have 200 kA or higher interrupting ratings.
- Selective coordination with loadside and lineside fuses is easy to achieve if all the fuses in the system are Bussmann series Low-Peak fuses and the amp ratio between each pairing of lineside to loadside fuses is 2:1 or greater.

**Chapter 7 Special Conditions**  
**Article 701 Legally Required Standby Systems**  
**Part I. General**  
**701.5 Transfer Equipment**  
**701.5(D) Documentation**

**NEW**

**Significance of the addition**

Legally required standby system transfer equipment must be field marked on the enclosure exterior with the SCCR for the specific installation. This change makes it easier for inspectors to verify the SCCR for legally required standby system transfer equipment is met. See 700.5(E) in this publication for more information.

**Related NEC sections**

- 110.10
- 700.5(E)
- 702.5
- 708.24(E)

See pages 4 to 7 for an in-depth SCCR discussion and pages 23 to 25 for resources and 26 to 27 for products.

**What to look for:**

- Legally required standby system transfer equipment is field marked on the enclosure exterior with the SCCR from the manufacturer's equipment marking label that corresponds to the specific installation (voltage, OCPD type, amp rating, setting, etc.).
- If the transfer equipment SCCR is equal to or greater than the available short-circuit current.

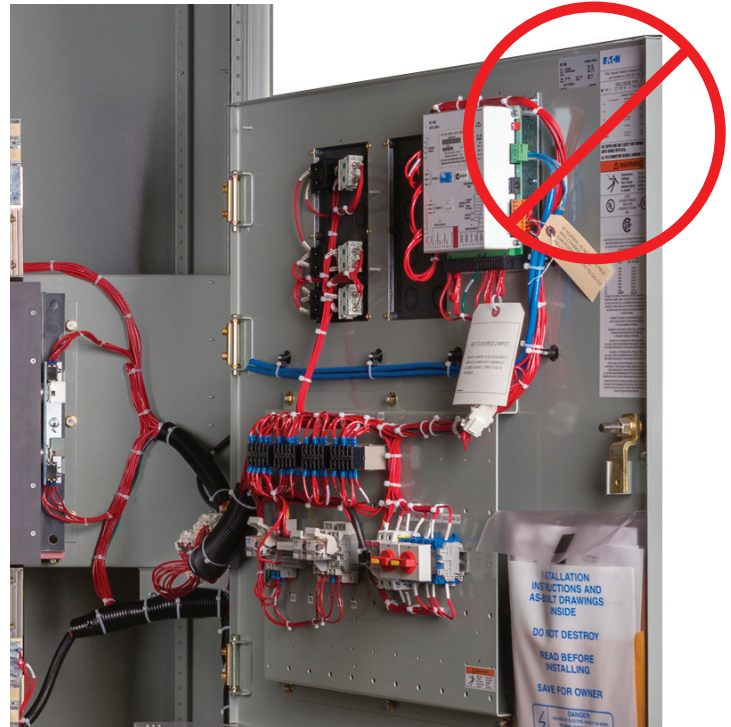

*An SCCR field marking for the specific installation of emergency system transfer equipment must be made on the enclosure exterior — not the interior. The manufacturer's nameplate SCCR marking is on the inside*

**Chapter 7 Special Conditions**  
**Article 702 Optional Standby Systems**  
**Part I. General**  
**702.5 Transfer Equipment**

**REVISION**

**Significance of the change**

The SCCR for optional standby system transfer equipment must be field marked on the enclosure's exterior. This change makes it easier for inspectors to verify the SCCR for optional standby system transfer equipment complies with 110.10.

This changed requirement for optional standby systems is similar to the new requirement for emergency systems. See 700.5(E) in this publication.

In some cases, the transfer switch for an optional standby system is an ATS and may be listed for emergency systems. However, the transfer

switches for optional standby systems are not required to be automatic and they are not required to be listed for emergency systems. For example, transfer equipment may use other transferring devices such as double throw switches and interlocking circuit breakers.

UL 98 Enclosed and Dead-Front Switches evaluates double throw switches and UL 67 Panelboards evaluates panelboards with interlocking circuit breakers. The SCCR for this equipment may be easier to determine compared to transfer equipment for emergency use.

**Related NEC sections**

- 110.10
- 701.5(D)
- 702.5
- 708.24(E)

See pages 4 to 7 for an in-depth SCCR discussion and pages 23 to 25 for resources and 26 to 27 for products.

**What to look for:**

- Optional standby system transfer equipment is field marked on the enclosure exterior with the SCCR from the manufacturer's equipment marking label that corresponds to the specific installation (voltage, OCPD type, amp rating, setting, etc.).
- If the equipment SCCR is equal to or greater than the available short-circuit current.

**Significance of the addition**

Critical Operation Power System (COPS) transfer equipment must be field marked on the enclosure exterior with the SCCR specific to the installation. This addition makes it easier for inspectors to verify the SCCR for critical operation power system transfer equipment. See 700.5(E) in this publication for more information.

**Related NEC sections**

110.10

700.5(E)

701.5(E)

702.5

See pages 4 to 7 for an in-depth SCCR discussion and pages 23 to 25 for resources and 26 to 27 for products.

**What to look for:**

- Critical operation power system transfer equipment is field marked on the enclosure exterior with the SCCR from the manufacturer’s equipment marking label that corresponds to the specific installation (voltage, OCPD type, amp rating, setting, etc.).
- If the field marked transfer equipment SCCR is equal to or greater than the available short-circuit current.







**Product Solution for ATS protection**

The proper selection of overcurrent protective devices installed in the electrical distribution system that are intended to provide protection for ATSS is critical. For emergency systems, legally required standby systems, and critical operations power systems, these OCPDs must provide short-circuit protection for the ATSS, selectively coordinate with loadside and lineside fuses, and have an adequate interrupting rating.

This is an easy protection task when using Bussmann series Low-Peak™ fuses:

- Low-Peak fuses have 300 kA\* interrupting ratings.
- ATSS usually are listed and labeled with a 200 kA SCCR (short-circuit withstand/closing rating) when protected by Low-Peak fuses.
- Low-Peak fuses have selectivity lineside to loadside amp rating ratio of only 2:1.

\* LP-CC is rated 200 kA.

 <b>LPJ_SP</b> 600 Vac, 1 to 600 A time-delay Class J  Easily mounts in Class J holders, blocks and switches	 <b>CUBEFuse</b> 600 Vac, 1 to 100 A time-delay Class CF  Compact, finger-safe design	 <b>KRP-C_SP</b> 600 Vac, 601 to 6000 A time-delay Class L  Up to 800 amp versions easily mount in Class L holders, blocks and switches
 <b>LPN-RK_SP</b> 250 Vac, 1 to 600 A time-delay Class RK1  Easily mounts in Class R holders, blocks and switches	 <b>LPS-RK_SP</b> 600 Vac, 1 to 600 A time-delay Class RK1  Easily mounts in Class R holders, blocks and switches	 <b>LP-CC</b> 600 Vac, up to 30 A time-delay Class CC  Small size, easily mounts in Class CC holders, blocks and switches



# Annex 1

## Practical approaches to determining available short-circuit current

The available short-circuit current must be established before Code compliance can be achieved. Ideally, an available short-circuit current study has already been completed for a facility prior to, or at the time of, installing electrical distribution switchboards and panelboards, or as part of an arc flash study. If no study was performed, then the available short-circuit current must be determined from design information, or gathered at the installation site. This information may be challenging to obtain, depending on the equipment's installation location and the arrangement of the electrical distribution system.

However, some practical approaches can be applied with information requirements ranging from minimal to very detailed. The Code requires that the equipment SCCR be at least equal to, but not less than the available short-circuit current. Thus a quick and simple calculation that provides a conservative (on the high side) available short-circuit current value can be used. It may be more beneficial in some cases to use an approach that requires minimal effort, yielding a more conservative value, than an approach that yields a value closer to actual conditions.

Any of the following approaches, from simple to complex, can be used to determine available short-circuit current.

### Use data from an existing available short-circuit current study

- Ideally, a study has already been completed that details the facility locations where the equipment is to be installed. The study can be used as the source when the available short-circuit current is required to be documented. In cases where a marking is required, the study details can be used to create the required equipment labels. If an existing study is used, it's important to verify that no system changes have been made that would alter the calculated available short-circuit current since the study was performed. It is also worth noting that often the available short-circuit current calculations are determined just down to the panelboard level, but not further downstream. In these situations, the panelboard's calculated value may be used as a conservative value, as the actual available short-circuit current will be lower due to conductor impedance.
- Benefit: No calculation required.
- Resultant value: Nearest the actual value, or close to the actual value if the study did not evaluate points downstream of the panelboard.
- Considerations: Verify no changes have been made since the study was performed.

### Complete a simple calculation based solely on the nearest upstream transformer's attributes

- The required information (size/kVA, secondary voltage, phase, percent impedance) can be obtained from the transformer's nameplate. The benefit to this approach is a simplified calculation that assumes an infinite available short-circuit current on the transformer primary and ignores the affect of conductors on the secondary. When equipment can meet this SCCR requirement, it can be relocated to any point downstream of the transformer.
- Benefit: Simple calculation using information that is readily accessible along with equipment relocation flexibility.
- Resultant value: Most conservative, as it's based on the available short-circuit current at the transformer's secondary. The actual available short-circuit current is less than this value.

### Complete a detailed calculation

- This approach requires the same information as the previous simple calculation approach, but also requires detail for each conductor between the transformer and the location where the equipment is to be installed. When the conductor is a wire, then the conductor size, length, material, quantity per phase, and conduit type are required. For busway type conductors, this detail includes the ampacity, material, length and type.
- Benefit: Most accurate and provides the lowest available short-circuit current value of all approaches, and lowers that equipment SCCR needed.
- Resultant value: Most accurate, as it's closest to the actual available short-circuit current.

To further simplify calculation of available short-circuit current, Eaton provides a free tool called the *Bussmann series FC<sup>2</sup> Fault Current Calculator*. See the resource section for more information.



The Eaton Bussmann Division's Paul P. Gubany Center for High Power Technology is the electrical industry's most comprehensive facility for testing and certifying device and equipment SCCRs. Capable of performing electrical tests up to 600 volt three-phase, 300,000 amps of short-circuit current for meeting ANCE, ANSI, CE, CSA, ETL, IEC and UL testing requirements.



# Annex 2

## Best practices for SCCR requirements during various project stages

This table contains “best practice” suggestions that apply whether a project is a new building, adding new equipment to an existing building or moving a piece of equipment within or between facilities.

### Best practice suggestions for SCCR requirements during various project stages

Project stage	Best practices
<p><b>Design</b></p> <ul style="list-style-type: none"> <li>- For all electrical equipment, determine the available short-circuit current.</li> </ul>	<ul style="list-style-type: none"> <li>- Electrical distribution system designer determines available short-circuit currents.</li> <li>- Electrical distribution system designer communicates available short-circuit currents to each entity responsible for specifying the various types of electrical equipment, such as:               <ul style="list-style-type: none"> <li>- Switchgear, switchboard, power distribution panelboard, panelboards, MCCs, etc.</li> <li>- HVAC equipment</li> <li>- Industrial control panels</li> <li>- Industrial machinery</li> <li>- Elevator controller</li> <li>- Automatic Transfer Switch equipment (ATSs)</li> </ul> </li> <li>- Those responsible for various types of equipment specifications should specify the required SCCRs.</li> <li>- Specify a minimum equipment SCCR that will be adequate for anywhere in the facility. The level specified should be high enough to accommodate any equipment relocation inside the facility or improvements to the electrical system that would result in higher available short-circuit current.</li> <li>- Electrical distribution system designer submits plans with available short-circuit currents to AHJs.</li> <li>- Designer evaluates “value engineering” submittals to ensure equipment SCCRs will be adequate.</li> <li>- Before approving designs and drawings for industrial control panels, require the OEM to verify the SCCR using compliance software such as the <i>Bussmann series OSCAR 2.1</i> and submit the documentation it provides.</li> </ul>
<p><b>Procurement</b></p> <ul style="list-style-type: none"> <li>- Each party responsible for ordering electrical equipment communicates the required SCCR specification to equipment builders (original equipment manufacturers/OEMs).</li> </ul>	<ul style="list-style-type: none"> <li>- OEMs make the available short-circuit current or SCCR a required part of the specification information the customer must submit.</li> <li>- OEMs who provide the same solution at varying SCCR ratings are easier to work with in regard to applying adequately rated equipment in the most cost effective manner.</li> <li>- For simplicity, and to gain a competitive advantage, OEMs should design their equipment with high SCCRs, such as at 65 kA or 100 kA.</li> </ul>
<p><b>Installation</b></p> <ul style="list-style-type: none"> <li>- Do not install electrical equipment unless the SCCR is equal to or greater than the available short-circuit current.</li> <li>- Field mark the available short-circuit current where required.</li> <li>- Field mark the SCCR on the outside of transfer equipment.</li> </ul>	<ul style="list-style-type: none"> <li>- Before installing, verify the equipment SCCR is equal to or greater than the available short-circuit current. If the SCCR is less than the available short-circuit current, do not proceed, and notify those responsible that it’s inadequate and needs correcting before installation can be made. Once installed, it is much more difficult to correct an inadequate equipment SCCR.</li> <li>- Contractors for distribution systems and equipment verify SCCR is equal to or greater than the available short-circuit current.</li> <li>- If the installation for a circuit is substantially different from the design, contractors should verify that the equipment SCCR is still equal to or greater than the available short-circuit current.</li> <li>- If contractors recommend “value engineering” changes, be sure to verify equipment SCCRs remain adequate.</li> </ul>
<p><b>Inspection — Authority Having Jurisdiction (AHJ)</b></p> <ul style="list-style-type: none"> <li>- Verify that the electrical equipment SCCRs are equal to or greater than the available short-circuit current.</li> <li>- Verify compliance with field marking requirements.</li> <li>- An AHJ is always responsible whether the project is a new building, adding process equipment to an existing electrical system or moving electrical equipment.</li> </ul>	<ul style="list-style-type: none"> <li>- AHJ requires plan submittals with available short-circuit currents so this information is available for installation inspections.</li> <li>- AHJ field verifies that equipment marked SCCRs are equal to or greater than the available short-circuit current.</li> <li>- AHJ reviews “value engineering” changes to ensure equipment SCCRs remain adequate.</li> </ul>

# Annex 3

## Product solutions for adjustable speed drive short-circuit protection

### Product solutions

The table below provides OCPDs that are likely to meet the enhanced safety requirements of UL 61800-5-1. Equipment manufacturers who integrate adjustable speed drives into their equipment should stay informed and incorporate the proper OCPD and SCCR data into their markings and instructions. For more in-depth information on adjustable speed drive overcurrent protection options please contact your Eaton Bussmann Division Field Application Engineer.

**Note:** Installers and users must default to the manufacturer's instructions or markings. If the adjustable speed drive label or instructions require specific type/ampere fuse(s) or specific manufacturer's fuse model number, then that OCPD must be used per NEC 110.3(B) and UL 508C or UL 61800-5-1.

### Adjustable speed drive short-circuit overcurrent protective device suggestions (600 V or less) for UL 61800-5-1\*

Adjustable speed drive capacity/type	Preferred [key reason]	Other types
≤ 5 HP	LP-CC or KTK-R (Class CC) [small physical size]	TCF or FCF (Class CF), LPJ, JKS, or DFJ (Class J), JJJ/JJS (Class T) fuses or Type E self-protected starter**
≤ 50 HP	TCF(Class CF), LPJ_SP (Class J) [time-delay for bypass, finger safe disconnects and holders] JJN/JJS (Class T) fuses: [small size]	FCF (Class CF), JKS (Class J) or Type E self-protected starter**
≤ 200 HP	DFJ high speed fuse (Class J) [standard Class J holders and switches] CHSF compact high speed fuses (UL Recognized) [compact size]	FW ferrule high speed fuses (UL Recognized)
> 200 HP	170M square body high speed fuses (UL Recognized) [many mounting configurations]	FW ferrule high speed fuses (UL Recognized)
Servo drive or drive DC output	North American cylindrical high speed fuses (UL Recognized):	IGBT high speed fuses (UL Recognized)

\* The fuses in this table are current-limiting. However, there are different degrees of current-limitation which is a key consideration in adjustable speed drive protection. There are other considerations, such as available ampere rating range, physical size, fuse mounting configurations, available fuse holders, blocks, and switches, finger-safe options, and time-delay for when adjustable speed drive is in bypass mode.

\*\* Type E self-protected starters are typically limited by a slash voltage rating, such as 480/277 V.

### Products

#### High speed fuses



**CHSF**

500 Vac/dc, 50 to 400 A, compact high speed fuses

Require up to 48% less space



**DFJ\***

600 Vac, 1 to 600 A, Class J

Easily mounts in Class J holders, blocks and switches.  
\* Class J branch circuit fuse.



**FW**

Up to 1000 Vac, 1 to 100 A ferrule

Small size



**North American**

Up to 1000 Vac, 1 to 4000 A cylindrical



**170M**

Up to 2000 Vac, 10 to 7500 A, square body

Higher voltage and power



**IGBT**

Up to 1000 Vdc, 25 to 630 A

Compact size

#### Branch circuit fuses



**Time-delay LP-CC and fast-acting KTK-R**

600 Vac, 1/4 to 30 A, Class CC

Small size, easily mounts in Class CC holders, blocks and switches



**Time-delay and fast-acting CUBEFuse™**

600 Vac, 1 to 100 A, Class CF

Compact, finger-safe design



**Time-delay LPJ and fast-acting JKS**

600 Vac, 1 to 600 A, Class J

Easily mounts in Class J holders, blocks and switches



**JJJ (300 Vac) and JJS (600 Vac)**

1 to 1200 A (JJJ) and 1 to 800 A (JJS), Class T

Compact size



# Annex 4

## Bussmann series resources to help achieve SCCR compliance

### Bussmann series FC<sup>2</sup> Available Fault Current Calculator

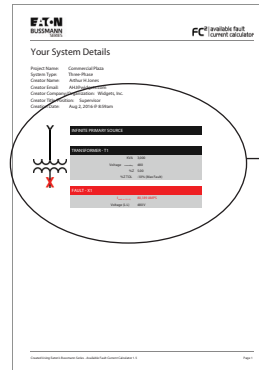
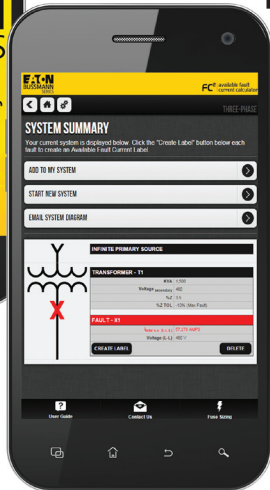

FC<sup>2</sup> provides a dated printout that documents the calculation and the system values used to determine the available short-circuit current.

Knowing the available short-circuit current is essential for Code compliance with SCCR requirements. This no-cost application is available online or as a free, mobile app download. FC<sup>2</sup> provides users:

- The option to use English, Spanish or French.
- Calculations for three-phase and single-phase systems.
- Documentation for the available short-circuit current at one or multiple points in an electrical system.
- An easy way to comply with field marking requirements by creating and emailing 110.24 labels, in jpeg or PDF formats.
- A system printout that documents the calculation along with the date it was performed.
- The option to generate labels and documentation in English, Spanish or French.

Visit [Eaton.com/bussmannseries/FC2](http://Eaton.com/bussmannseries/FC2) or scan the QR code above for downloading an Apple® iPhone/iPad or Android™ mobile device compatible version.

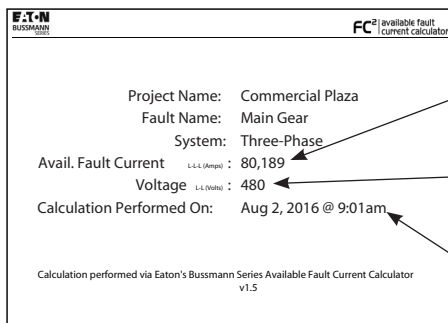

Available short-circuit current

System voltage

Date and time of calculation

Bussmann series FC<sup>2</sup> available fault current calculator produces label images of the available short-circuit current calculation for field marking equipment.

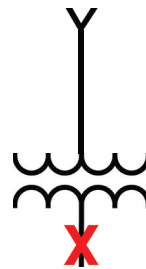

INFINITE PRIMARY SOURCE	
TRANSFORMER - T1	
KVA	3,000
Voltage secondary	480
%Z	5.00
%Z TOL	-10% (Max Fault)
FAULT - X1	
$I_{total\ s.c.\ (L-L-L)}$	80,189 AMPS
Voltage (L-L)	480 V

Short-circuit current is calculated on the transformer secondary assuming infinite available short circuit-current on the primary.

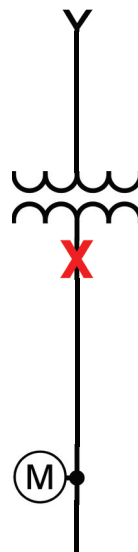

INFINITE PRIMARY SOURCE	
TRANSFORMER - T1	
KVA	750
Voltage secondary	480
%Z	5.00
%Z TOL	-10% (Max Fault)
FAULT - X1	
$I_{s.c.\ (L-L-L)}$	20,047 AMPS
$I_{s.c.\ motor\ cont.}$	1,804 AMPS
$I_{total\ s.c.\ (L-L-L)}$	21,851 AMPS
Voltage (L-L)	480 V
MOTOR CONTRIBUTION - M1	
MOTOR VOLTAGE	480 V
MOTOR F.L.A.	451 AMPS
MOTOR CONTRIBUTION	1,804 AMPS

FC<sup>2</sup> is capable of using many circuit variables to calculate available short-circuit current, including motor contribution.

# Annex 4

## Bussmann series resources to help achieve SCCR compliance

### Bussmann series OSCAR™ 2.1 SCCR Online Compliance Software

Bussmann series OSCAR™ 2.1 online compliance software greatly simplifies determining equipment SCCRs. This award-winning tool easily guides users through entering an electrical panel's devices, calculates its equipment SCCR and provides documented results.

#### OSCAR 2.1:

- Lets users create a one-line diagram of a control panel's circuit from a vast database of over 65,000 devices.
- Permits entering custom devices and their electrical values.
- Calculates the panel's SCCR.
- Highlights the "weak links" that limit equipment SCCR.
- Allows for editing the one-line diagram with higher SCCR devices to achieve a higher equipment SCCR.
- Permits printing one-line diagrams.
- Provides a report of devices and their ratings to document compliance with UL 508A Supplement SB for equipment SCCR marking requirements covering Industrial Control Panels (409.110), Industrial Machinery Electrical Panels (670.3(A)) and HVAC Equipment (440.4(B)).

Available 24/7 — 365, OSCAR 2.1 creates a one-line diagram from specified devices and calculates the equipment SCCR. Red circles identify the "weak links" limiting the equipment SCCR.

Subscribers can create and save as many one-line diagrams as they want. To save time and effort with similar panel circuits, one-line diagrams can be copied and modified for easier calculations.

To subscribe or request a free 7-day trial, visit [OSCAR.Eaton.com](http://OSCAR.Eaton.com).

### Eaton's SCCR Protection Suite

This free, online resource is a comprehensive product portfolio of circuit protection and wiring distribution/termination and switching devices.

It provides equipment designers with easy access to product information for meeting a broad range of SCCR needs from 18 kA to 200 kA.

With SCCR Protection Suite, designers can:

- Select circuit attributes:
  - Desired panel SCCR
  - Circuit location (branch or feeder)
  - Circuit type (device combinations)
  - Circuit power and control voltage
  - Load type and amps (motor or non-motor)
- View options for:
  - Upstream current limitation
  - Component preferences (fuses/circuit breakers, disconnects, contactors/starters, drives, power and terminal blocks, etc.)

After a search is made, results include a detailed listing of the devices, their catalog numbers, ratings, SCCR and their UL references.

This resource greatly helps designers eliminate "weak links" by easily and quickly searching for solutions that raise the component SCCR or limit the short-circuit current. Visit [SCCR.Eaton.com](http://SCCR.Eaton.com).



# Annex 4

## Bussmann series resources to help achieve SCCR compliance

### Application notes, literature and whitepapers

Both industrial equipment manufacturers and users need to know about SCCR, and the related Code and regulatory requirements. The following documents will help provide insight into this often misunderstood subject and how to effectively plan and implement an SCCR strategy.

- Application note No. 10367 — Developing an effective SCCR plan for facilities and purchasers of industrial equipment.
- Application note No. 10368 — Developing an equipment SCCR standard for manufacturers of industrial equipment.
- Brochure No. 10374 — Equipment SCCR made easy.
- Whitepaper No. WP083020EN — Applying current-limiting devices to raise SCCR.

Visit [Eaton.com/SCCR](http://Eaton.com/SCCR).

### Product catalogs

The following Bussmann series product catalogs and application guide are available for viewing and download at [Eaton.com/bussmannseries](http://Eaton.com/bussmannseries).

- Full line product catalog No. 1007 — Over 560 pages of Bussmann series products, accessories and services.
- Rotary disconnect catalog No. 10076 — 48 pages on UL 98 fused and non-fused disconnects up to 1200 amps and UL 508 non-fused disconnects up to 80 amps.
- DIN-Rail terminal blocks catalog No. 3197 — 48 pages of DIN-Rail terminal blocks with SCCR up to 200 kA.
- High speed fuse catalog No. 10506 — 100 pages covering North American, square body, ferrule and BS88 high speed fuse offerings.
- High speed fuse application guide No. 10507 — 36 pages covering the considerations and factors affecting the selection and application of high speed fuses.

### More resources

- Eaton's Application Engineering team — available for no-cost SCCR analysis of equipment one-line diagrams and schematics. Email [FuseTech@Eaton.com](mailto:FuseTech@Eaton.com).
- Eaton Bussmann Division Field Application Engineers — contact your Bussmann series product sales representative for details.

### Bussmann series Selecting Protective Devices (SPD) Handbook

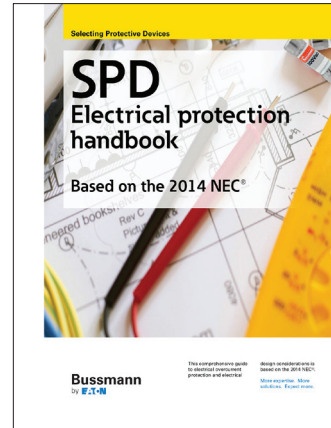

With over 250 pages, this comprehensive circuit protection handbook has an entire section on 110.24, including methods for calculating point-to-point short-circuit current at multiple points in single-phase and three-phase systems. To download this valuable resource, visit [www.cooperbussmann.com/SPD](http://www.cooperbussmann.com/SPD).



Eaton's Bussmann Division Application Engineering team is available to preform a no-cost equipment SCCR analysis.

# Annex 5

## Bussmann series products to help achieve SCCR compliance

Panel designers can easily achieve high equipment SCCRs. UL 508A Supplement SB is a rule-based analysis method for determining an industrial control panel's SCCR which is too detailed to explain in this publication. However, Figure 5 and Table 3 summarize the five keys to achieving high panel SCCRs using this method. For more in-depth explanation, contact Eaton's Bussmann Division Application Engineering team or an Eaton Bussmann Field Application Engineer.

Bussmann series products provide a means to achieve high SCCRs with fuses having high interrupting ratings and excellent current-limitation. Also, common circuit devices by industry manufacturers, such as motor starters and drives, have high listed SCCRs, when in combination with Bussmann series fuses.

### Legend for Figure 5

- ① Branch circuit OCPD with high interrupting rating.
- ② Branch circuit device with high listed SCCR in combination with branch circuit OCPD.
- ③ Feeder OCPD with high interrupting rating.
- ④ Feeder device with high listed SCCR in combination with feeder OCPD.
- ⑤ Increase branch circuit SCCR to even higher SCCR using feeder OCPD's current-limiting let-through data. A branch circuit OCPD's interrupting rating cannot be raised using a feeder OCPD's current-limitation — low interrupting rating OCPDs are a limitation to achieving high panel SCCR.

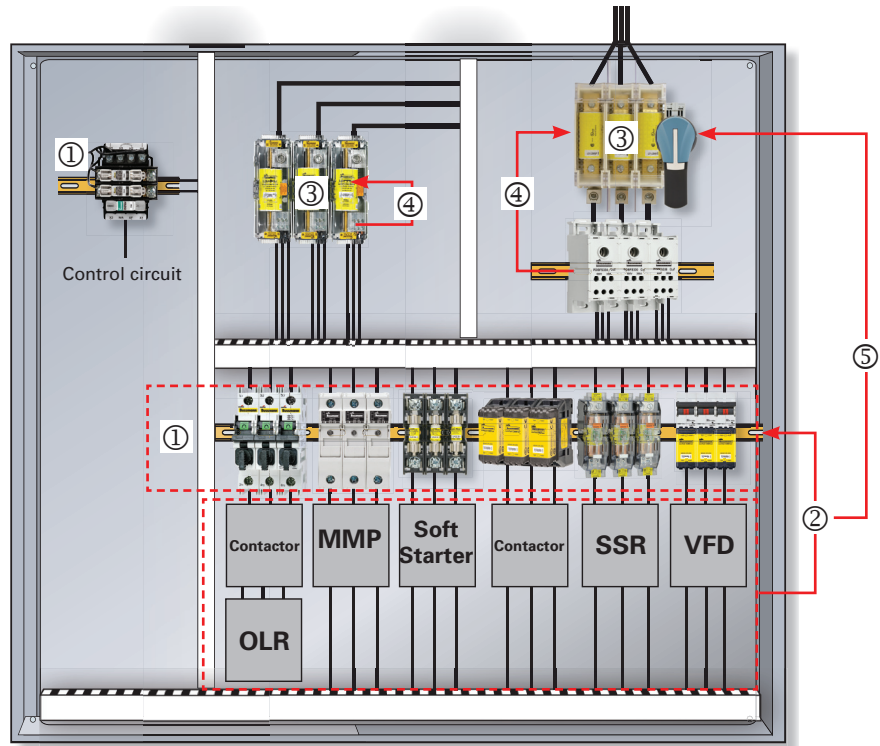

Figure 5. Five keys to increasing control panel SCCR. See legend for explanations.

**Note:** The panel SCCR can be no greater than the lowest interrupting rating of any OCPD in the panel power circuits.

Table 3. Keys to achieving high panel SCCRs

Location	Keys to achieving high control panel SCCRs *	Why they are key?	Bussmann series product advantages
Branch circuits	① OCPDs with high interrupting ratings.	<ul style="list-style-type: none"> <li>Panel SCCR is limited to the lowest OCPD interrupting rating.</li> <li>OCPD interrupting ratings cannot be raised by a feeder OCPD's current-limitation as permitted for branch circuit SCCRs in ③ below.</li> </ul>	<ul style="list-style-type: none"> <li>Bussmann series fuses typically have 200 kA or greater interrupting ratings, and do not limit panel SCCR.</li> </ul>
	② Tested and listed high SCCR devices.	<ul style="list-style-type: none"> <li>For panel SCCR analysis, each branch circuit SCCR is based upon the lowest device SCCR in the circuit.</li> </ul>	<ul style="list-style-type: none"> <li>Branch circuit devices are commonly available with tested and listed high SCCRs when protected by specified Bussmann series fuses, e.g., a motor starter has a 100 kA SCCR when protected by Bussmann series fuses.</li> <li>Protection of power conversion equipment may require Bussmann series high speed fuses per the manufacturing's instructions.</li> </ul>
Feeder circuits	③ OCPDs with high interrupting ratings.	<ul style="list-style-type: none"> <li>Panel SCCR is limited to the lowest OCPD interrupting rating.</li> </ul>	<ul style="list-style-type: none"> <li>Bussmann series fuses typically have 200 kA or greater interrupting ratings, and do not limit panel SCCR.</li> </ul>
	④ Tested and listed high SCCR devices.	<ul style="list-style-type: none"> <li>A feeder circuit device's SCCR cannot be increased by the feeder OCPD's current-limiting capability (as described in ③ below).</li> </ul>	<ul style="list-style-type: none"> <li>Bussmann series power distribution blocks are available with tested and listed high SCCRs when protected by specified Bussmann series fuses.</li> <li>Patented Bussmann series power distribution fuse blocks provide listed high SCCRs while reducing component count and space.</li> </ul>
	⑤ Listed current-limiting OCPDs.	<ul style="list-style-type: none"> <li>By analysis, feeder OCPD current-limiting let-through data can increase individual branch circuit SCCRs to even higher levels.</li> </ul>	<ul style="list-style-type: none"> <li>Bussmann series fuses, with a high degree of current-limitation, can be selected to increase the branch circuit SCCR to a much higher level, making it easier to achieve a high panel SCCR.</li> </ul>

\* See UL 508A, Supplement SB for details.

# Annex 5

## Bussmann series products to help achieve SCCR compliance

### ① Branch OCPDs with high interrupting ratings.



**LPJ-SP**

600 V, 1 to 600 A  
time-delay Class J

Easily mounts in Class J holders, blocks and switches



**CUBEFuse**

600 V, 1 to 100 A  
time-delay Class CF

Compact, finger-safe design mounts in holders and CCP\_CF switches



**LP-CC**

600 V, up to 30 A  
time-delay Class CC

Small size, mounts in Class CC holders, blocks and switches

*Bussmann series branch circuit fuses offer high interrupting ratings up to 300 kA.*

### ③ Feeder circuit OCPDs with high interrupting ratings.



**KRP-C\_SP**

600 V, 601 to 6000 A  
time-delay Class L

Easily mounts in Class L blocks and switches



**LPJ-SP**

600 V, 1 to 600 A  
time-delay Class J

Easily mounts in Class J holders, blocks and switches

*Bussmann series feeder circuit fuses offer high interrupting ratings up to 300 kA.*

### ② Branch circuit devices with tested and listed high SCCRs.



**LP-CC**

600 V, up to 30 A  
time-delay Class CC

Small size, easily mounts in Class CC holders, blocks and switches



**CUBEFuse**

600 V, 1 to 100 A  
time-delay Class CF

Compact, finger-safe design mounts in holders or CCP\_CF switches



**JJN (300 V) and JJS (600 V)**

1 to 1200 A (JJN) and 1 to 800 A (JJS), Class T



**DFJ**

600 V, 1 to 600 A  
high speed fuses  
(UL Class J)



**CHSF**

500 V, 50 to 400 A,  
compact high speed fuses

*Use branch circuit devices, such as contactors, motor controllers, solid state relays, motor starters, soft starters, adjustable speed drives and terminal blocks, which have high listed SCCRs when in combination with Bussmann series fuses.*

### ④ Feeder circuit devices with tested and listed high SCCRs.



**PDBFS\_**

200 kA SCCR finger-safe, DIN-Rail mount 600 V modular power distribution blocks up to 760 A

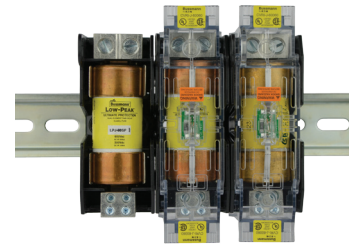

**JM600\_-MW\_**

200 kA SCCR, 600 V Class J ferrule and knifeblade modular power distribution fuse blocks up to 400 A. Optional covers provide IP20 protection.

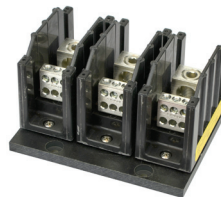

**PDB\_-**

200 kA SCCR panel mount 600 V power distribution blocks up to 760 A



**CHCC and CH\_J**



**TCF\_H**



**CCP\_-30CC and CCP\_-CF**

200 kA, 600 V UL listed disconnects; Class CC and CF fuses up to 100 A.

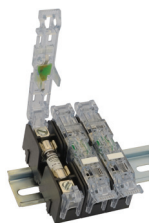

**BCM603\_-**



**JM60\_-**



**RDF\_-**

200 kA, 600 V rotary disconnect switches for Class CC, J and L fuses up to 800 A.

*Finger-safe fuse holders and blocks increase electrical safety.*

### ⑤ Listed feeder current-limiting OCPDs.



**KRP-C\_SP**

600 V, 601 to 6000 A time-delay Class L



**LPJ-SP**

600 V, 1 to 600 A time-delay Class J

*See UL 508A table SB4.2 for let-through values.*

**Customer satisfaction team:**

Available to answer questions regarding Bussmann series products and services Monday-Friday, 7:00 a.m. — 6:00 p.m. Central time.

- Toll-free phone: 855-287-7626 (855-BUSSMANN)
- Toll-free fax: 800-544-2570
- Email: [busscustsat@eaton.com](mailto:busscustsat@eaton.com)

**Emergency and after-hours orders:**

Next flight out or will call shipment for time-critical needs. Customers pay only standard product price, rush freight charges, and modest emergency service fee. Place these orders through the customer satisfaction team during regular business hours.

- After hours: 314-995-1342

**My.Eaton.com:**

Provides real time product availability, net pricing, order status and shipment tracking. Log onto [my.eaton.com](http://my.eaton.com) or call:

- 1-800-468-1705 Option #3 for log-in assistance.

**Application engineering:**

Technical assistance is available to all customers. Application support is available Monday-Friday, 7:00 a.m. — 5:00 p.m. Central time.

- Toll-free phone: 855-287-7626 (855-BUSSMANN)
- Email: [Fusetech@eaton.com](mailto:Fusetech@eaton.com)

**Eaton**  
1000 Eaton Boulevard  
Cleveland, OH 44122  
[Eaton.com](http://Eaton.com)

Bussmann Division  
114 Old State Road  
Ellisville, MO 63021  
United States  
[Eaton.com/bussmannseries](http://Eaton.com/bussmannseries)

© 2016 Eaton  
All Rights Reserved  
Printed in USA  
Publication No. 10508  
August 2016

Eaton, Bussmann, Low-Peak, CUBEFuse and OSCAR are valuable trademarks of Eaton in the US and other countries. You are not permitted to use the Eaton trademarks without prior written consent of Eaton.

NEC is a registered trademark of the National Fire Protection Association, Inc.  
NFPA is a registered trademark of the National Fire Protection Association, Inc.  
UL is a registered trademark of the Underwriters Laboratories, Inc.

For Eaton’s Bussmann series product information, call **1-855-287-7626** or visit: **[Eaton.com/bussmannseries](http://Eaton.com/bussmannseries)**



Follow us on social media to get the latest product and support information.

