

Champ Pro PFMA LED floodlights

20,000 to 50,000 lumens

UL/cUL Listed
IEC/CE
Type 4X; IP66

5L

The Champ Pro PFMA LED family

39% lighter than the previous design with a small footprint

Champ® Pro PFMA high lumen LED floodlights are designed to provide full-spectrum, crisp, white light. Four versions of the PFMA are available, providing ideal solutions for a wide range of applications.

Model	Nominal lumens	Watts ^A	Equivalent MH luminaire	Typical energy savings / lifetime
PFMA20L	20,500	177	600W-750W	Up to 78% reduction in energy costs and 120,000 hours of continuous operation
PFMA25L	25,500	217	750W-1000W	
PFMA40L	40,500	340	1500W+	
PFMA50L	50,500	400		

Applications:

- Locations requiring continuous and consistent light levels in extreme ambient temperatures
- Areas requiring frequent on-and-off of lights
- Where extremely corrosive, wet, dusty, hot and/or cold conditions exist
- Manufacturing plants, heavy industrial, chemical, food and beverage facilities, mining, platforms, loading docks, tunnels, outdoor wall and pole mounted areas

Features:

- Rugged design – engineered to perform in ambient temperatures from -40°C to 55°C
- High efficiency – engineered to deliver 117 lumens per watt
- Full frame yoke – designed to utilize the SFA6 slipfitter and SWB6 wall mount bracket, making it ideal for retrofit or new installations^B
- Custom optics – standard 7x6 pattern provides maximum light distribution
- 5 year fixture warranty



PFMA20L/PFMA25L

PFMA40L/PFMA50L

Certifications and compliances:

NEC model:

NEC/CEC:

- Type 4X, IP66
- ABS

UL standards:

- UL1598; UL1598A; cUL

IEC/CE model:

IEC:

- IEC 60598-1 and IEC 60598-2-1
- Wet locations
- IP66
- CE marked

Standard materials:

- Lamp housing and adapter – die cast aluminum with Corro-free™ epoxy powder coat
- Lens – heat- and impact-resistant glass (standard)
- Gaskets – silicone and neoprene
- External hardware – stainless steel

Fixture life:

- Rated life of 60,000 hours at 55°C operating ambient and 24/7 continuous operation for 365 days

Photometrics:

- Refer to www.eaton.com (under the Resources tab of each product family) for specific photometric IES files

Electrical ratings – NEC model:

Model	120-277 VAC at 50/60 Hz		347-480 VAC at 50/60 Hz	
	Input power	Input amps	Input power	Input amps
PFMA20L	177W	1.76A	177W	0.52A
PFMA25L	217W	2.18A	216W	0.63A
PFMA40L	340W	3.35A	338W	1.24A
PFMA50L	400W	4.14A	400W	1.54A

All models (UNV1 only)

Voltage range, VDC 127-300V at 50/60 Hz

All models

Power factor >0.90

Electrical ratings – IEC model:

Model	120-277 VAC at 50/60 Hz		347-440 VAC at 50/60 Hz	
	Input power	Input amps	Input power	Input amps
nPFMA20L	177W	1.76A	177W	0.52A
nPFMA25L	217W	2.18A	216W	0.63A
nPFMA40L	340W	3.35A	338W	1.24A
nPFMA50L	400W	4.14A	400W	1.54A

All models (UNV1 only)

Voltage range, VDC 127-300V at 50/60 Hz

All models

Power factor >0.90

^A UNV1 at 120 VAC.

^B SFA6 slipfitter and SWB6 wall mount bracket sold separately (20L/25L models only).

Champ Pro PFMA LED floodlights

20,000 to 50,000 lumens

UL/cUL Listed
IEC/CE
Type 4X; IP66

5L



Smaller and lighter

- 25% smaller footprint than previous model
- 20 lbs. less weight than previous model

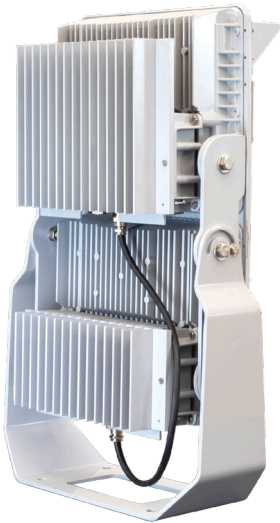

Full frame yoke

- Designed to utilize the SFA6 slipfitter and SWB6 wall mount bracket, making it ideal for retrofit or new installation (for 20L and 25L models)

Rugged heat sink

- Heat sink designed to perform and provide maximum light levels in high ambient temperatures up to +55°C and as low as -40°C
- Thick walled castings make for a tough, rugged housing that keeps the internal driver and LED temperature down



Versatile design

- Can be used for outdoor or indoor applications, and for a wide range of mounting heights depending on model and light level requirement

High lumen output

- Up to 120 lumens per watt
- Up to 78% energy savings over traditional HID fixtures (compared to 400W MH)

Multiple lens options

- Tempered clear glass lens standard
- Diffused glass lens optional



Champ Pro PFMA LED floodlights

20,000 to 50,000 lumens

UL/cUL Listed
IEC/CE
Type 4X; IP66

5L

Ordering information:

Part number example

PFMA20LCY/UNV34 76 M20 S891

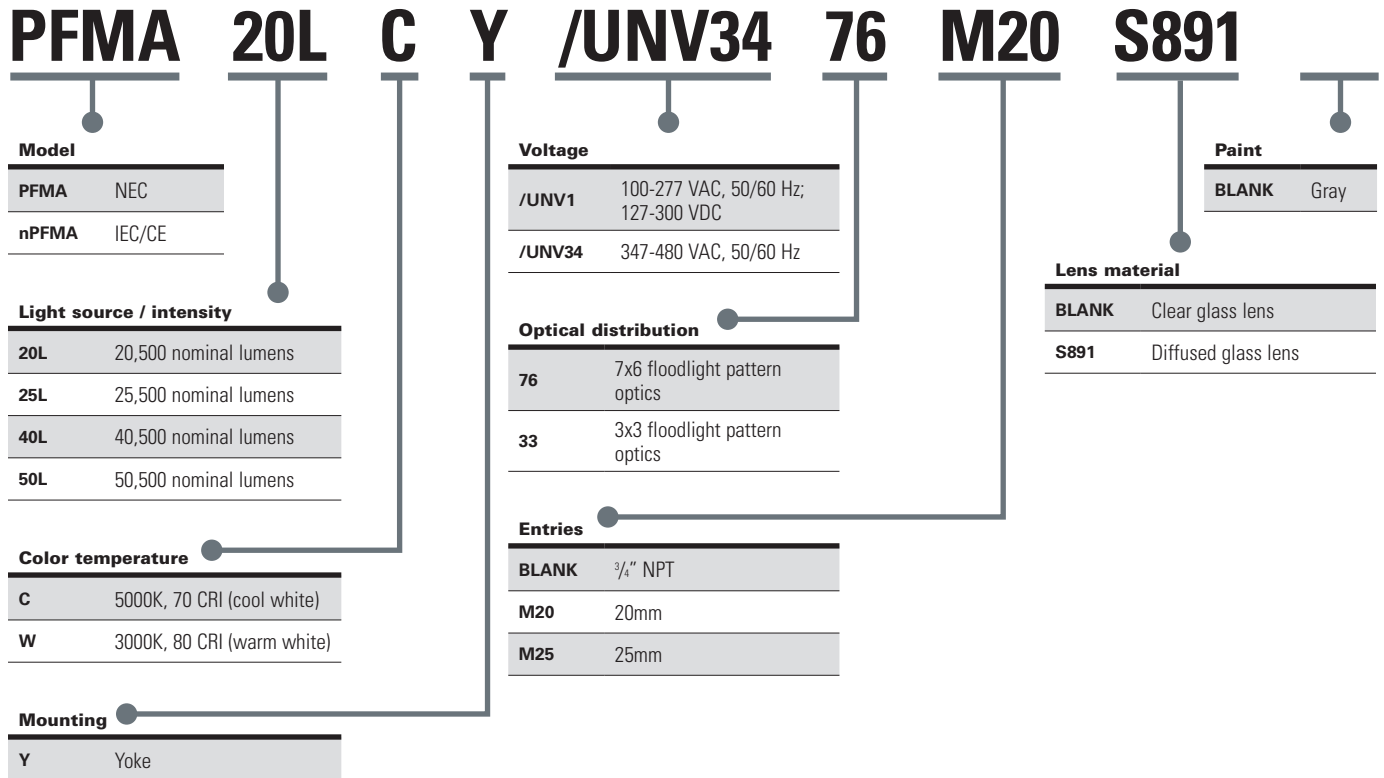

Accessories (ordered separately):

Description	Cat. #	Description	Cat. #
• Bull horn, 2 tenon, gray	BLHN2	• Bolt-on visor.....	DSV2
• Bull horn, 3 tenon, gray	BLHN3	• Bolt-on wire guard	P62
		• Safety cable	SC831
		• Slipfitter	SFA6
		• Slipfitter wall mount adapter	SWB6

Replacement driver kits (ordered separately)

PFMA 20L/25L UNV1 DRIVER KIT	UNV1 replacement driver kit for PFMA20L & PFMA25L models
PFMA 20L/25L UNV34 DRIVER KIT	UNV34 replacement driver kit for PFMA20L & PFMA25L models

20L and 25L models only.

Champ Pro PFMA LED floodlights

20,000 to 50,000 lumens

UL/cUL Listed
IEC/CE
Type 4X; IP66

5L

Dimensions and weights – PFMA20L/PFMA25L:

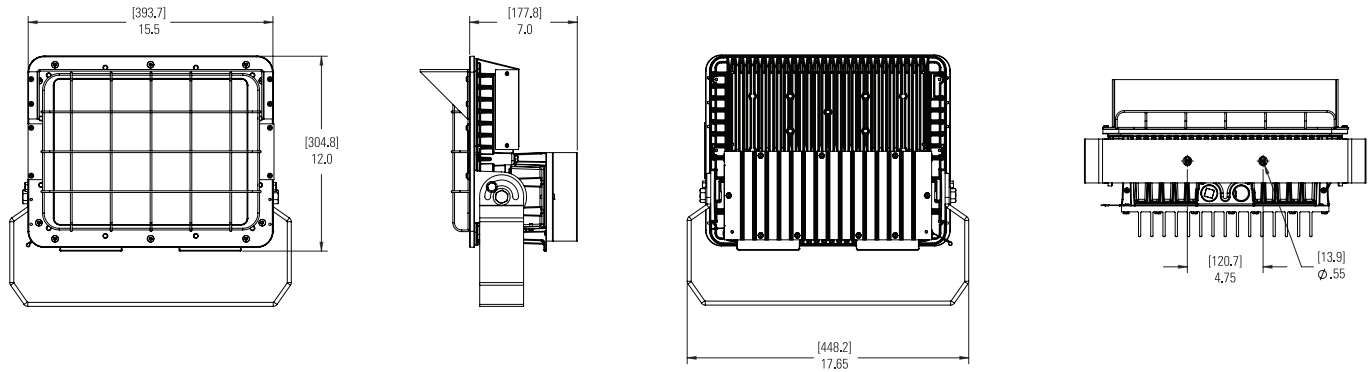

Model	Width		Height		Depth		Weight	
	in.	mm.	in.	mm.	in.	mm.	lb.	kg.
PFMA20L & 25L	15.50	393.70	12.00	304.80	7.00	177.80	34.00	15.40

Effective projected area

Position (tilt)	ft.-sq.
at 0°	1.50
at 45° backwards	1.10
at 60° forward	0.80

5L

Dimensions – PFMA40L/PFMA50L:

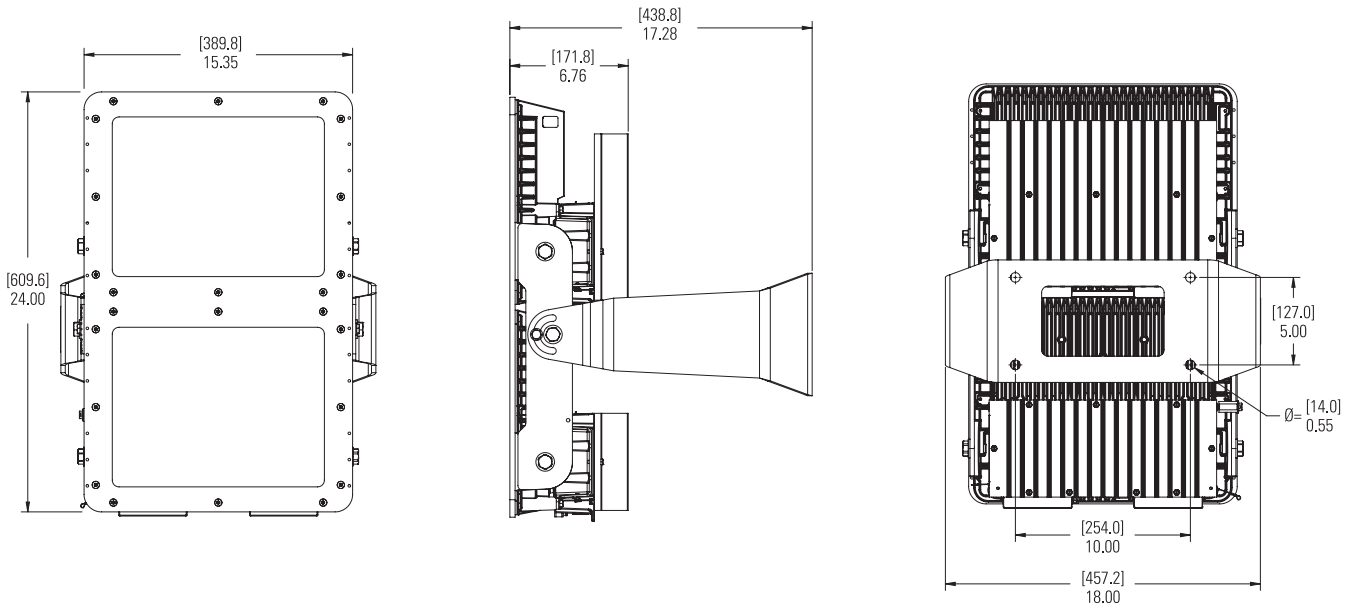

Model	Width		Height		Depth		Weight	
	in.	mm.	in.	mm.	in.	mm.	lb.	kg.
PFMA40L & 50L	18.00	457.20	24.00	609.60	17.28	438.80	77.00	34.90

Effective projected area

Position (tilt)	ft.-sq.
at 0°	3.20
at 45° backwards	3.25
at 60° forward	3.62