

Ex-Lite LED exit signs

Cl. I, Div. 2, Groups A, B, C, D
 Cl. I, Zone 1, AEx em ib IIC (NEC)
 Cl. I, Zone 1, Ex em ib IIC (CEC)
 Cl. II, Div. 2, Groups F, G (NEC)
 Cl. II, Div. 2, Groups E, F, G (CEC)

CSA Certified
 IP66

7L

Ex-Lite LED exit signs are designed for hazardous locations and are ideally suited for marking escape routes and exits in potentially explosive atmospheres.

The Ex-Lite Z is available as an AC only version, while the Ex-Lite ZE is available with self-contained battery. As an emergency lighting luminaire with self-contained battery system, the Ex-Lite ZE features a nickel cadmium battery with automatic test and monitoring feature.

Applications:

- In harsh and hazardous environments where illuminated exit signs are required

Features:

LED technology:

- Long life (>50K hours) for years of maintenance-free operation
- Energy-efficient for lower cost of operation
- Low temperature operation with no loss of illumination
- Rugged and durable light source for the harshest of environments

Exit sign system:

- Can be used in a hazardous location
- Conduit or cable entry
- Can be installed in moist, humid, rainy and wet environments
- Universal input voltage 110-277 VAC and 110-250 VDC reduces inventory
- Ex-Lite ZE with self-monitoring, self-diagnostic and test capability
- Premium heavy duty nickel cadmium battery
- 24-hour charge and recharge time increases safety by recovering quickly from outage
- "EXIT" legend with alternative wings – left, right or left and right; simple field modification
- Emergency lighting cycle three hours
- Luminaire housing is constructed with a corrosion-resistant, robust, lightweight aluminum alloy material and illumination of the sign is provided with red, high efficient LEDs

Certifications and compliances:

- Class I, Division 2, Groups A, B, C, D
- Class I, Zone 1, AEx em ib IIC (NEC)
- Class I, Zone 1, Ex em ib IIC (CEC)
- Class II, Division 2, Groups F, G (NEC)
- Class II, Division 2, Groups E, F, G (CEC)
- IP66
- UL844
- UL924 CAN/CSA C22.2 No. 141-15
- UL60079 / CSA22.2 E60079
- UL1203 / CSA22.2 E6124-1-1-02



Ordering information:

	Ex-Lite Z / ZR	Ex-Lite ZE / ZER
Description	AC/DC exit sign	With battery
Light source	LED	LED
Life of LED	50K hours	50K hours
Rated voltage, VAC	120V-277V	120V-277V
Frequency	50/60 Hz	50/60 Hz
Rated voltage, VDC	110V-250V	110V-250V
Power consumption	6VA	6VA
Battery	N/A	NiCad
Allowable temperature range	-4°F to 122°F (-20°C to 50°C)	41°F to 95°F (5°C to 35°C) ^A
Mounting	Wall	Wall
Cable entry	Ex-e	Ex-e
Conduit entry	3/4"	3/4"
Protection	IP66	IP66

Series	Cat. #	Description
Ex-Lite Z	12191001005	Cover with red inscription "EXIT"
Ex-Lite ZE	12191130005	Cover with red inscription "EXIT", with self-contained emergency version
Ex-Lite ZER	12191130022	Cover with running man and arrow 9h with self-contained emergency version
Ex-Lite ZER	12191130021	Cover with running man and arrow 3h with self-contained emergency version
Ex-Lite ZER	12191130023	Cover with running man and arrow 6h with self-contained emergency version
Ex-Lite ZR	12191001022	Cover with running man and arrow 9h
Ex-Lite ZR	12191001021	Cover with running man and arrow 3h
Ex-Lite ZR	12191001023	Cover with running man and arrow 6h



^A Due to battery chemistry, the charging capacity will be limited at temperatures below 5°C and above 35°C.

7L

Ex-Lite LED exit signs

Cl. I, Div. 2, Groups A, B, C, D
Cl. I, Zone 1, AEx em ib IIC (NEC)
Cl. I, Zone 1, Ex em ib IIC (CEC)
Cl. II, Div. 2, Groups F, G (NEC)
Cl. II, Div. 2, Groups E, F, G (CEC)

CSA Certified
IP66

7L

Dimensions:

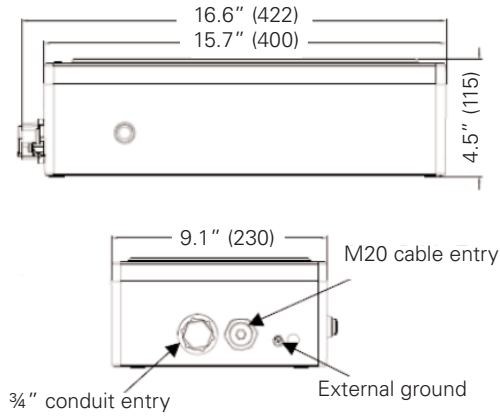

7L