



Quick Start Guide

Smart Switch EWFSW15



Amazon, Alexa and all related logos are trademarks of Amazon.com, Inc. or its affiliates. Google and Google Play are trademarks of Google LLC. Wi-Fi CERTIFIED logo is a trademark of the Wi-Fi Alliance.



www.eaton.com
www.eaton.com/wiringdevices

EIS-0282-E (REV. C)

Eaton's Wi-Fi Smart Devices

Eaton's broad selection of **Wi-Fi Smart Devices** offer reliability with unbeatable ease of setup. Every device sets up quickly and easily with the Brightlayer Home App—no hubs or controllers are necessary. You can add voice-control using any Alexa or Google device.

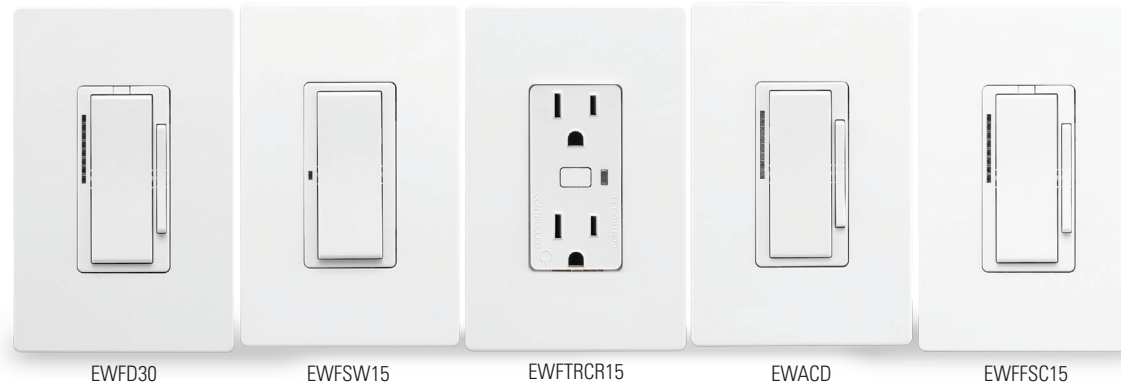

EWFD30 EWFSW15 EWFTRCR15 EWACD EWFFSC15

For more information on the complete Wi-Fi smart product portfolio please visit Eaton.com/smarthome



Set up and control in the Brightlayer Home App



Voice control with Alexa and Hey Google



Easy installation



No hub required



Set schedules, groups, and scenes



Amazon, Alexa and all related logos are trademarks of Amazon.com, Inc. or its affiliates. Google and Google Play are trademarks of Google LLC. Wi-Fi CERTIFIED logo is a trademark of the Wi-Fi Alliance.



Your Wi-Fi Smart Switch

Control your lights from anywhere with Eaton's **Wi-Fi Smart Switch (EWFSW15)** which replaces standard switches and features ON/OFF control. The switch can be remotely controlled using the Brightlayer Home App.

15A 120V 60Hz 1/2HP



Neutral is required
Single pole & 3-way



Features

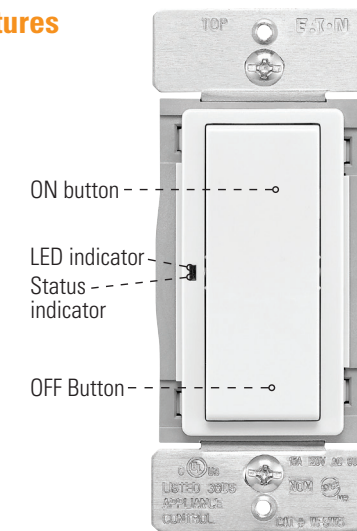

Tools needed

Tools required for installation (not included) for the **Wi-Fi Smart Switch (EWFSW15)**:



Phillips-head Screwdriver



Wire cutters



Additional system requirements



A 2.4GHz Wi-Fi network with high-speed internet



IOS 12.0 or later or Android 8.0 or later mobile device. **Note:** Must be connected to Wi-Fi and Bluetooth



A Brightlayer Home account set-up through the Brightlayer Home App



Prior to installation

Requires neutral for installation

WARNINGS AND CAUTIONS:

- Turn OFF circuit breaker or remove fuse(s) and test that power is OFF before installation process
- Never wire any electrical device with power turned ON. Wiring switch HOT may cause permanent damage to switch and void warranty
- If you are not sure about any part of these instructions, please contact a licensed electrician

CAUTION

- Use only with 120V/AC 60Hz
- Do not exceed maximum rating of switch as indicated on the device
- Must be installed and used in accordance with all national and local electrical codes
- If a bare copper or green ground connection is not available in the wallbox, contact a licensed electrician for installation
- Use only #14 or #12 copper wire rated for at least 75°C with these devices

DO NOT USE WITH ALUMINUM WIRE

IMPORTANT: Wi-Fi Smart Switch (EWFSW15) will not work or will be damaged if wired incorrectly and warranty will be voided. Refer to wiring instructions provided.

NOTE: The Wi-Fi Smart Switch (EWFSW15) is wired directly to the light fixture. For Multi-location applications (3-way) a regular 3-way switch can be used.



Single location installation (Black lines)

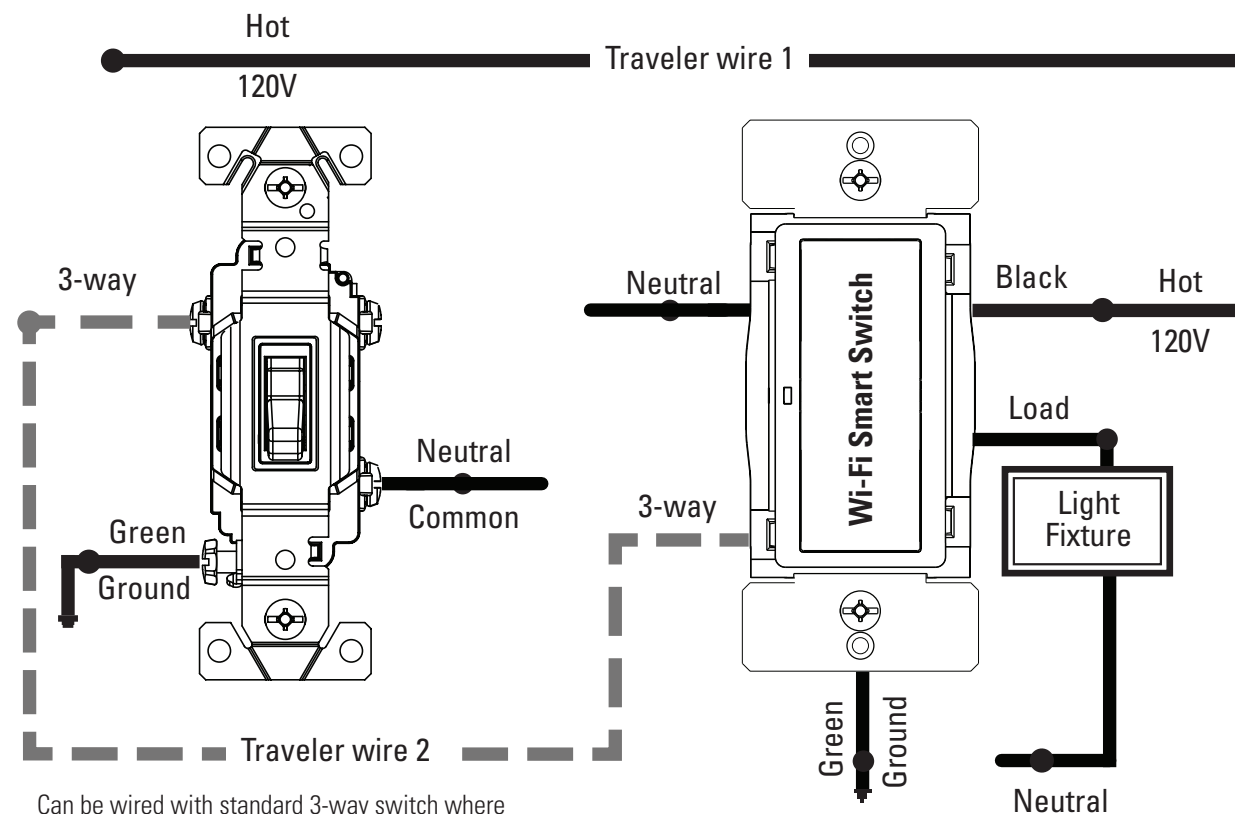

Can be wired with standard 3-way switch where traveler wire exists for 3-way.



Two location control using a 3-way switch (gray lines)



Operation instructions

- Press ON button to turn lights ON
- Press OFF button to turn lights OFF
- When the lights are ON, press and hold the OFF button for 2 seconds until the LED indicator blinks. After a 10 second delay, the lights will turn off

FACTORY RESET: The switch can be reset which will exclude the device from its network and restore all factory defaults.

- Press and hold the ON button until the LED indicator blinks for the second time (30 secs)
- Release the button
- The LED indicator will start blinking again indicating the switch is not part of the Wi-Fi network



Safely leave room before lights turn off



Scan for more advanced features including adjusting the brightness level of the LED indicators and additional wiring configurations

For color change kit installation instructions, see back page



End User license agreement

Software included with the Eaton product is hereby licensed to You, and Eaton retains for itself (or, if applicable, its suppliers) all title and ownership to any software delivered hereunder. Without Eaton's authorization, You shall not copy, disclose or display the software, or otherwise make it available to others, and shall not attempt any sale, transfer, sublicense, reverse compilation or disassembly or redistribution of the software. By using the software, You agree to the terms of Eaton's End User License Agreement at:

<https://www.eaton.com/WiFiSmartEULA>



Contact us:



www.eaton.com/smarthome



Eaton.com/chat



TechSupport@eaton.com

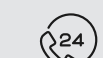

Phone (Toll Free): 877-386-2273
Device support: Option 5 then Option 3
App support: Option 2 then Option 9
Fax (Toll Free): 800-329-3055

How to download the App

Download the App
Search and download the **Brightlayer Home** App via the App Store or Google Play.
Select "Create an Account" to create an account by following the instructions on the screen.

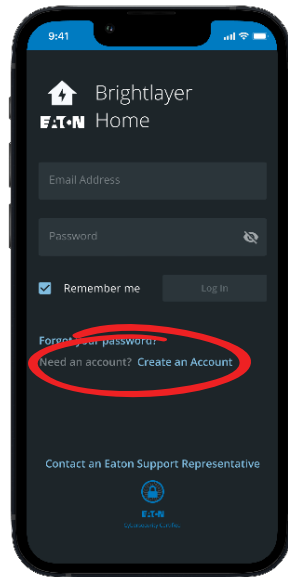

For more information, visit Eaton.com/smarthome

Get your Wi-Fi Smart Device running in 3 easy steps!

Set-up the Device

Add your device to the Brightlayer Home App

STEP 1 : Double click on the "ON" button on the **Wi-Fi Smart Switch (EWFSW15)**. Status LED on the Wi-Fi Smart Switch should be blinking cyan to indicate that the device is in set-up mode. If the status LED is not blinking, refer to the Troubleshooting guide.

STEP 2 : Log in to your account on the Brightlayer Home App

STEP 3 : Select "Devices" option



Once initial device is installed, additional devices can be added using the global add (+) button.



STEP 3 (continued) :

Next click on "Add a Device" option shown in the screen below

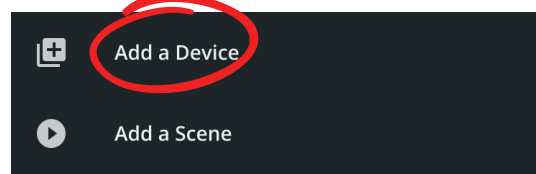

Select the device type to add

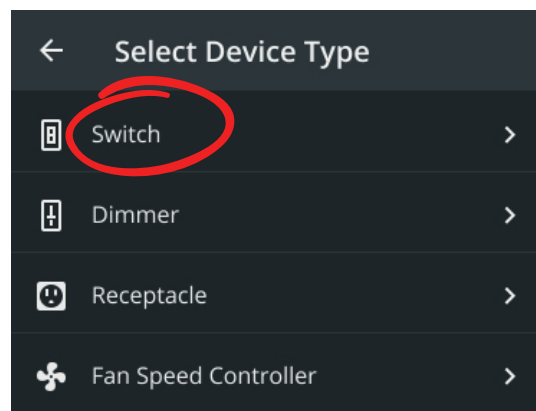

STEP 3 (continued) :

Once selected the devices would be displayed as shown below:

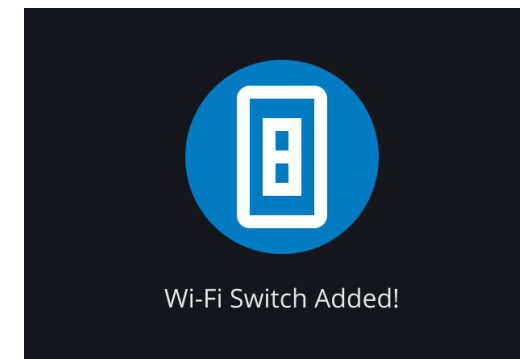

Note: Now the user can utilize many features that are available such as creating schedules, scenes, preset light levels and minimum/maximum brightness settings through the Brightlayer Home App.

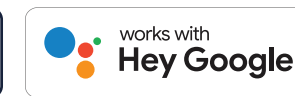

Amazon, Alexa and all related logos are trademarks of Amazon.com, Inc. or its affiliates. Google and Google Play are trademarks of Google LLC. Wi-Fi CERTIFIED logo is a trademark of the Wi-Fi Alliance.

Warranty

FCC STATEMENT

This device complies with Part 15 of the FCC Rules. Operation is subject to the following two conditions:

1: This device may not cause harmful interference, and
2: This device must accept any interference received, including interference that may cause undesired operation.

NOTE: This equipment has been tested and found to comply with the limits for a Class B digital device, pursuant to Part 15 of the FCC Rules. These limits are designed to provide reasonable protection against harmful interference in a residential installation. This equipment generates, uses and can radiate radio frequency energy and, if not installed and used in accordance with the instructions, may cause harmful interference to radio communications. However, there is no guarantee that interference will not occur in a particular installation. If this equipment does cause harmful interference to radio or television reception, which can be determined by turning the equipment off and on, the user is encouraged to try to correct the interference by one or more of the following measures:

- Reorient or relocate the receiving antenna.
 - Increase the separation between the equipment and receiver.
 - Connect the equipment into an outlet on a circuit different from that to which the receiver is connected.
 - Consult the dealer or an experienced radio/TV technician for help.
- FCC CAUTION:** Any changes or modifications not expressly approved by Eaton Wiring Devices could void the user's authority to operate the equipment.

This device complies with Industry Canada's license-exempt RSSs. Operation is subject to the following two conditions:

(1) This device may not cause interference; and
(2) This device must accept any interference, including interference that may cause undesired operation of the device.

EATON WIRING DEVICES LIMITED 2 YEAR WARRANTY

Eaton Wiring Devices warrants its Switch to be free of defects in materials and workmanship in normal use and service for a period of two years from date of original purchase. THIS TWO (2) YEAR LIMITED WARRANTY IS IN LIEU OF ALL OTHER WARRANTIES, OBLIGATIONS, OR LIABILITIES, EXPRESSED OR IMPLIED (INCLUDING ANY IMPLIED WARRANTY OF MERCHANTABILITY OR FITNESS FOR A PARTICULAR PURPOSE THAT IS IN DURATION IN EXCESS OF TWO YEARS FROM THE DATE OF ORIGINAL CONSUMER PURCHASE). NO AGENT, REPRESENTATIVE, OR EMPLOYEE OF EATON HAS AUTHORITY TO INCREASE OR ALTER THE OBLIGATIONS OF EATON UNDER THIS WARRANTY. To obtain warranty service for any properly installed Eaton Switch that proves defective in normal use send the defective Switch prepaid and insured to Quality Control Dept., Eaton Wiring Devices, 203 Cooper Circle, Peachtree City, GA 30269; in Canada: Eaton Wiring Devices, 5925 McLaughlin Road, Mississauga, Ontario L5R 1B8. Eaton will repair or replace the defective unit, at its option. Eaton will not be responsible under this warranty if examination shows that the defective condition of the unit was caused by misuse, abuse, improper installation, alteration, improper maintenance or repair of damage in shipment to Eaton. EATON SHALL HAVE NO RESPONSIBILITY FOR INSTALLATION OF THE Switch, OR FOR ANY PERSONAL INJURY, PROPERTY DAMAGE, OR ANY SPECIAL, INCIDENTAL, CONTINGENT, OR CONSEQUENTIAL DAMAGES OF ANY KIND, RESULTING FROM DEFECTS IN THE Switch OR FOR BREACH OF ANY EXPRESS OR IMPLIED WARRANTY ON THIS PRODUCT. THE EXCLUSIVE REMEDY FOR BREACH OF THE LIMITED WARRANTY CONTAINED HEREIN IS THE REPAIR OR REPLACEMENT OF THE DEFECTIVE PRODUCT AT EATON'S OPTION. IMPLIED WARRANTIES (IF ANY) INCLUDING, BUT NOT LIMITED TO IMPLIED WARRANTIES OF FITNESS FOR A PARTICULAR PURPOSE AND MERCHANTABILITY, ARE LIMITED IN DURATION TO A PERIOD ENDING TWO YEARS FROM THE DATE OF ORIGINAL CONSUMER PURCHASE. IN NO CASE SHALL EATON'S LIABILITY UNDER ANY OTHER REMEDY PRESCRIBED BY LAW EXCEED THE PURCHASE PRICE. Some states do not allow the exclusion or limitation of incidental or consequential damages or allow disclaimers or modifications of or limitations on how long an implied warranty lasts, so the above limitations may not apply to you. Some Canadian provinces do not allow exclusion or variance of implied warranties so that some or all of the above limitations may not apply to you. This warranty gives you specific legal rights and you may also have other rights which vary from state to state and province to province. Read enclosed instructions carefully. If you have any questions concerning use or care of this product, please write: Consumer Service Division, Eaton Wiring Devices, 203 Cooper Circle, Peachtree City, GA 30269.

LED status

Quick reference table for Wi-Fi Smart Switch (EWFSW15) functionality

Function	Device state	Button	Number of seconds to press	LED indicator color	Default
Delayed OFF time	ON	OFF	2	Green	10 seconds
Power up state	ON	OFF	5	Blue	OFF
Power LED indicator OFF brightness	OFF	OFF	15	Yellow	Level 0
Power LED indicator ON brightness	ON	ON	15	Yellow	Level 4
Factory reset	ON/OFF	ON	30	Red	

Troubleshooting guide

Symptom	Possible Cause	Solution
Device doesn't function. All LEDs are OFF	A) Circuit breaker is open or tripped B) Improper wiring C) Defective switch	A) Turn ON/Close the circuit breaker B) Check and correct wiring C) Replace switch
Erratic operation or flickering LEDs	Loose wiring connections	Check wiring and following instructions provided with the device
Device functions normally using the switch push buttons but not from Brightlayer Home App. Purple LED indicator is blinking ON and OFF about once per second	Switch is not included in the Wi-Fi network	A) Include the switch in the Wi-Fi network using Brightlayer Home App B) Check that the router is functioning properly C) Go through the factory reset procedure and re-add the device to the Brightlayer Home App
Device functions normally using the switch push buttons but not from Brightlayer Home App. Yellow LED indicator is blinking ON and OFF about once per second	No Wi-Fi signal	Check the router
Device functions normally both locally and from a Brightlayer Home App but can't be controlled from a standard 3-way switch	The 3-way wire is not connected	Refer to the wiring connection and check if the 3-way wire is connected
Switch is warm to touch after a period of time	This is normal if the load is within the switch limits	No action required

Wi-Fi Smart Switch color change kit installation instructions

Available in 3 different color change kits



NOTE: Not all products include color change kits.

STEP 1 :
Squeeze top tabs on either side of the device

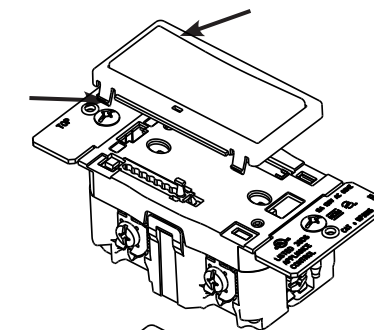

STEP 2 :
Pull faceplate off

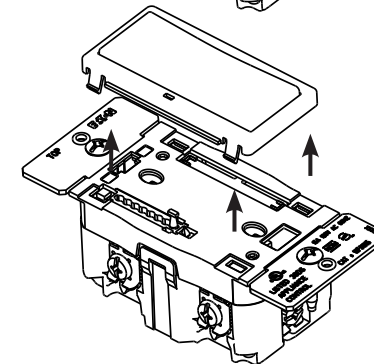

STEP 3 :
Line up all tabs and snap the faceplate on

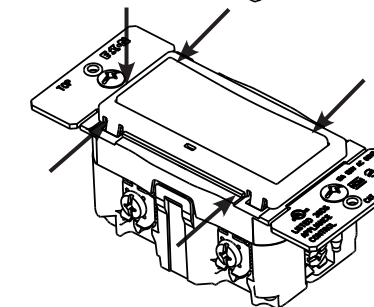

Your installation is finished!

Enjoy your new Wi-Fi Smart Switch!



For troubleshooting contact us at:
TechSupport@eaton.com or
call 1-877-386-2273 opt. 5 then opt. 3

Fold in half vertically with page 1 on outside, then Z-fold in horizontal direction to final folded size of 3.4 in. W x 5.5 in. H with part number facing outward.